

Lenovo ThinkSystem SR645 V3 Server Product Guide

The Lenovo ThinkSystem SR645 V3 is a dense, high performance, 2-socket 1U rack server. It is suitable for small businesses to large enterprises, and especially cloud service providers. The server features the 5th Gen AMD EPYC 9005 "Turin" family of processors and support for the new PCIe 5.0 standard for I/O. It is designed to handle a wide range of workloads such as cloud computing, virtualization, VDI, enterprise applications, and database management.

The server offers a broad selection of drive and slot configurations and offers high performance features. Outstanding reliability, availability, and serviceability (RAS) and high-efficiency design can improve your business environment and can help save operational costs.



Figure 1. Lenovo ThinkSystem SR645 V3

[360° View](#)

[Full 3D Tour](#)

Did you know?

The SR645 V3 server offers onboard NVMe PCIe ports that allow direct connections to 12x NVMe SSDs, which frees up PCIe slots and helps lower NVMe solution acquisition costs.

Key features

Combining performance and flexibility, the SR645 V3 server is a great choice for enterprises of all sizes. The server offers a broad selection of drive and slot configurations and offers high performance features that industries such as finance, healthcare and telco need. Outstanding reliability, availability, and serviceability (RAS) and high-efficiency design can improve your business environment and can help save operational costs.

Scalability and performance

The following features boost performance, improve scalability and reduce costs:

- Supports one or two 5th Gen AMD EPYC 9005 processors
 - Up to 160 cores and 320 threads
 - Core speed of up to 4.0 GHz
 - TDP rating of up to 400 W
- Supports one or two 4th Gen AMD EPYC 9004 processors
 - Up to 128 cores and 256 threads
 - Core speed of up to 4.1 GHz
 - TDP rating of up to 400 W
- Support for DDR5 memory DIMMs to maximize the performance of the memory subsystem:
 - Up to 24 DDR5 memory DIMMs, 12 DIMMs per processor
 - 12 memory channels per processor (1 DIMM per channel)
 - DIMM speeds up to 6400 MHz
 - Using 256GB 3DS RDIMMs, the server supports up to 6TB of system memory
- Supports up to five single-width GPUs, each up to 75W for substantial processing power in a 1U system.
- The server is Compute Express Link (CXL) v1.1 Ready. With CXL 1.1 for next-generation workloads, you can reduce compute latency in the data center and lower TCO. CXL is a protocol that runs across the standard PCIe physical layer and can support both standard PCIe devices as well as CXL devices on the same link.
- Supports up to 12x 2.5-inch hot-swap drive bays, by using combinations of front-accessible (up to 10 bays) and rear-accessible (2 bays).
- Supports four 3.5-inch drive bays for lower-cost high-capacity HDD storage. 2.5-inch and 3.5-inch drive bays can be mixed if desired.
- Supports 12x NVMe drives without the need for additional NVMe adapters and without oversubscription of PCIe lanes (1:1 connectivity). Additional NVMe support with the use of NVMe Retimer adapters, also without oversubscription. The use of NVMe drives maximizes drive I/O performance, in terms of throughput, bandwidth, and latency.
- Supports 12x SATA drives using the onboard SATA controller (no additional adapter needed), enabling lower cost, high capacity storage solution for cold storage workloads.
- Supports 12x SAS drives using a variety of support RAID controllers or SAS HBAs.
- Supports high-speed RAID controllers from Lenovo and Broadcom providing 12 Gb SAS connectivity to the drive backplanes. A variety of PCIe 3.0 and PCIe 4.0 RAID adapters are available.
- Supports two externally accessible 7mm hot-swap drives for operating system boot functions or data storage. Optional RAID-0 or RAID-1.
- Supports M.2 drives for convenient operating system boot functions. Available M.2 adapters support either one M.2 drive or two M.2 drives. Optional RAID-0 or RAID-1.
- Supports up to 5x PCIe slots, 3x at the rear of the server and 2x at the front of the server. Also supports 1x OCP 3.0 slot, either in the front or in the rear.

- The server has a dedicated industry-standard OCP 3.0 small form factor (SFF) slot, with a PCIe 5.0 x16 interface, supporting a variety of Ethernet network adapters. Simple-swap mechanism with thumbscrews and pull-tab enables tool-less installation and removal of the adapter. Supports shared BMC network sideband connectivity to enable out-of-band systems management.
- The server offers PCI Express 5.0 (PCIe Gen 5) I/O expansion capabilities that doubles the theoretical maximum bandwidth of PCIe 4.0 (32GT/s in each direction for PCIe 5.0, compared to 16 GT/s with PCIe 4.0). A PCIe 5.0 x16 slot provides 128 GB/s bandwidth, enough to support a 400GbE network connection.
- The server uses the Lenovo Neptune closed-loop liquid-cooled heatsink design to more effectively remove heat from high-performance processors.

Availability and serviceability

The server provides many features to simplify serviceability and increase system uptime:

- Designed to run 24 hours a day, 7 days a week
- The server uses ECC memory and supports memory RAS features including Single Device Data Correction (SDDC, also known as Chipkill), Patrol/Demand Scrubbing, Bounded Fault, DRAM Address Command Parity with Replay, DRAM Uncorrected ECC Error Retry, On-die ECC, ECC Error Check and Scrub (ECS), and Post Package Repair.
- The server offers hot-swap drives, supporting RAID redundancy for data protection and greater system uptime.
- Available M.2 configuration with RAID support which can enable two SATA or two NVMe M.2 drives to be configured as a redundant pair.
- The server has up to two hot-swap redundant power supplies and up to eight hot-swap redundant fans to provide availability for business-critical applications.
- Optional front-accessible slots and drives so that most major components and cables (except power) are located at the front of the server
- The power-source-independent light path diagnostics uses LEDs to lead the technician to failed (or failing) components, which simplifies servicing, speeds up problem resolution, and helps improve system availability.
- Solid-state drives (SSDs) offer more reliability than traditional mechanical HDDs for greater uptime.
- Proactive Platform Alerts (including PFA and SMART alerts): Processors, voltage regulators, memory, internal storage (SAS/SATA HDDs and SSDs, NVMe SSDs, M.2 storage), fans, power supplies, RAID controllers, server ambient and subcomponent temperatures. Alerts can be surfaced through the XClarity Controller to managers such as Lenovo XClarity Administrator, VMware vCenter, and Microsoft System Center. These proactive alerts let you take appropriate actions in advance of possible failure, thereby increasing server uptime and application availability.
- The built-in XClarity Controller 2 continuously monitors system parameters, triggers alerts, and performs recovery actions in case of failures to minimize downtime.
- Built-in diagnostics in UEFI, using Lenovo XClarity Provisioning Manager, speed up troubleshooting tasks to reduce service time.
- Lenovo XClarity Provisioning Manager supports diagnostics and can save service data to a USB key drive or remote CIFS share folder for troubleshooting and reduce service time.
- Auto restart in the event of a momentary loss of AC power (based on power policy setting in the XClarity Controller service processor)
- Offers a diagnostics port on the front of the server to allow you to attach an external diagnostics handset for enhanced systems management capabilities.
- Support for the XClarity Administrator Mobile app running on a supported smartphone and connected to the server through the service-enabled USB port, enables additional local systems management functions.

- Three-year or one-year customer-replaceable unit and onsite limited warranty, 9 x 5 next business day. Optional service upgrades are available.

Manageability and security

Systems management features simplify local and remote management:

- The server includes an XClarity Controller 2 (XCC2) to monitor server availability. Optional upgrade to XCC Platinum to provide remote control (keyboard video mouse) functions, support for the mounting of remote media files, FIPS 140-3 security, enhanced NIST 800-193 support, boot capture, and other management and security features.
- Lenovo XClarity Administrator offers comprehensive hardware management tools that help to increase uptime, reduce costs and improve productivity through advanced server management capabilities.
- UEFI-based Lenovo XClarity Provisioning Manager, accessible from F1 during boot, provides system inventory information, graphical UEFI Setup, platform update function, RAID Setup wizard, operating system installation function, and diagnostic functions.
- Support for Lenovo XClarity Energy Manager which captures real-time power and temperature data from the server and provides automated controls to lower energy costs.
- An integrated industry-standard Unified Extensible Firmware Interface (UEFI) enables improved setup, configuration, and updates, and simplifies error handling.
- Support for industry standard management protocols, IPMI 2.0, SNMP 3.0, Redfish REST API, serial console via IPMI
- An integrated hardware Trusted Platform Module (TPM) supporting TPM 2.0 enables advanced cryptographic functionality, such as digital signatures and remote attestation.
- Administrator and power-on passwords help protect from unauthorized access to the server.
- Supports AMD Secure Root-of-Trust, Secure Run and Secure Move features to minimize potential attacks and protect data as the OS is booted, as applications are run and as applications are migrated from server to server.
- Supports Secure Boot to ensure only a digitally signed operating system can be used.
- Industry-standard Advanced Encryption Standard (AES) NI support for faster, stronger encryption.
- Additional physical security features are a chassis intrusion switch and a lockable front bezel.

Energy efficiency

The following energy-efficiency features help save energy, reduce operational costs, and increase energy availability:

- Energy-efficient planar components help lower operational costs.
- High-efficiency power supplies with 80 PLUS Titanium certifications
- Low-voltage 1.1 V DDR5 memory offers energy savings compared to 1.2 V DDR4 DIMMs, an approximately 20% decrease in power consumption
- Solid-state drives (SSDs) consume as much as 80% less power than traditional spinning 2.5-inch HDDs.
- The server uses hexagonal ventilation holes, which can be grouped more densely than round holes, providing more efficient airflow through the system and thus keeping your system cooler.
- Optional Lenovo XClarity Energy Manager provides advanced data center power notification and analysis to help achieve lower heat output and reduced cooling needs.

Comparing the SR645 V3 to the SR645

The ThinkSystem SR645 V3 improves on the previous generation SR645, as summarized in the following table.

Table 1. Comparing the ThinkSystem SR645 V3 to the previous generation SR645

Feature	SR645	ThinkSystem SR645 V3	Benefits
Processor	<ul style="list-style-type: none"> • 2x 2nd or 3rd Gen AMD EPYC processors • Up to 64 cores • TDP ratings up to 280W • 64x PCIe 4.0 lanes per processor • 4x dedicated xGMI x16 interprocessor links 	<ul style="list-style-type: none"> • 2x 4th Gen or 5th Gen AMD EPYC processors • Up to 160 cores • TDP ratings up to 400W • 64x PCIe 5.0 lanes per processor • 4x dedicated xGMI x16 interprocessor links 	<ul style="list-style-type: none"> • Significant increase in cores per processor • Increased performance • Consolidation of more apps on same number of servers, reducing costs • New PCIe 5.0 support means higher performance networking and NVMe storage
Memory	<ul style="list-style-type: none"> • DDR4 memory operating up to 2933 MHz • 8 channels per CPU • 32 DIMMs (16 per processor), 2 DIMMs per channel • Supports RDIMMs and 3DS RDIMMs • Up to 8TB of system memory 	<ul style="list-style-type: none"> • DDR5 memory operating up to 6400 MHz • 12 channels per CPU • 24 DIMMs (12 per processor), 1 DIMM per channel • Supports RDIMMs, 3DS RDIMMs and 9x4 RDIMMs • Up to 6TB of system memory 	<ul style="list-style-type: none"> • New DDR5 memory offers significant performance improvements over DDR4 • More memory channels means greater memory bandwidth • Support for lower-cost 9x4 DIMMs
Internal storage	<ul style="list-style-type: none"> • Front: 4x 3.5" SAS/SATA or AnyBay hot-swap drive bays • Front: Up to 8x SAS/SATA hot-swap drives bays • Front: 10x 2.5" SAS/SATA/NVMe (up to 4 AnyBay or 10x NVMe) • Rear: Up to 2x 2.5" SAS/SATA or NVMe hot-swap drive bays • Rear: 2x 7mm SATA or NVMe hot-swap drive bays, optional RAID • 2x Internal M.2 with optional RAID 	<ul style="list-style-type: none"> • Front: 4x 3.5" SAS/SATA hot-swap drive bays • Front: Up to 8x SAS/SATA hot-swap drives bays • Front: 10x 2.5" SAS/SATA/NVMe (up to 4 AnyBay or 10x NVMe) • Front: 16x E1.S EDSFF NVMe hot-swap drive bays • Front: 4x 2.5" SAS/SATA + 3x PCIe slots (LP, FH, OCP) • Rear: Up to 2x 2.5" SAS/SATA or NVMe hot-swap drive bays • Rear: 2x 7mm SATA or NVMe hot-swap drive bays (optional RAID support) • 2x Internal M.2 with optional RAID 1 (optional RAID support) 	<ul style="list-style-type: none"> • Flexible storage offerings • Support for up to 12x 2.5" NVMe drives • New 16x E1.S configuration • New front PCIe slots configuration

Feature	SR645	ThinkSystem SR645 V3	Benefits
RAID	<ul style="list-style-type: none"> 8-port and 16-port RAID adapters with up to 8GB flash Support for Lenovo and Broadcom adapters Support for PCIe or Internal cabled (CFF) form factor adapters Support for NVMe drives connected to 940 RAID adapters (Tri-Mode) Storage HBAs available PCIe 3.0 and PCIe 4.0 adapter choices 	<ul style="list-style-type: none"> 8-port and 16-port RAID adapters with up to 8GB flash Support for Lenovo and Broadcom adapters Support for PCIe or Internal cabled (CFF) form factor adapters Support for NVMe drives connected to 940 RAID adapters (Tri-Mode) Storage HBAs available PCIe 3.0 and PCIe 4.0 adapter choices with support for Gen 5 adapters when available 	<ul style="list-style-type: none"> Consistent RAID/HBA support Flexible config solution PCIe Gen 5 allows for greater storage performance
Networking	<ul style="list-style-type: none"> OCP 3.0 slot with PCIe Gen 4 x16 interface (rear of server) Additional PCIe adapters supported 1GbE dedicated Management port 	<ul style="list-style-type: none"> OCP 3.0 slot with PCIe x16 interface (rear or front of server) Additional PCIe adapters supported 1GbE dedicated Management port 	<ul style="list-style-type: none"> Improved performance with PCIe Gen 5 Optional front-accessible OCP slot
PCIe	<ul style="list-style-type: none"> Up to 3x PCIe slots (all rear) 1x OCP 3.0 slot (rear) Support up to 3x 75W GPUs All slots PCIe Gen4 At the rear, supports either 3x slots (all LP) or 2x slots (LP + FH) FH slot connects to CPU 1 (slot 2) Additional OCP 3.0 slot Supports a RAID/HBA in CFF form factor (does not occupy a PCIe slot) 	<ul style="list-style-type: none"> Up to 5x PCIe slots (3 rear, 2 front) 1x OCP 3.0 slot, either rear or front Support up to 5x 75W GPUs Mix of PCIe Gen4 or Gen5 slots At the rear, supports either 3x slots (all LP) or 2x slots (LP + FH) FH slot connects to either CPU 1 (slot 2) or CPU 2 (slot 3) Additional OCP 3.0 slot Supports a RAID/HBA in CFF form factor (does not occupy a PCIe slot) Support for 3x front-accessible slots (2x PCIe + 1x OCP) with 4 drive bays 	<ul style="list-style-type: none"> More PCIe slots, up to 5 (3 rear, 2 front) + 1 OCP slot PCIe Gen 5 allows for greater I/O performance Support for more GPUs Flexible PCIe offerings Front-accessible slots available
Management and security	<ul style="list-style-type: none"> XClarity Controller Support for full XClarity toolset including XClarity Administrator Platform Firmware Resiliency (PFR) hardware Root of Trust (RoT) Tamper Switch security solution (intrusion switch) 	<ul style="list-style-type: none"> Integrated XClarity Controller 2 Support for full XClarity toolset including XClarity Administrator Platform Firmware Resiliency (PFR) hardware Root of Trust (RoT) Tamper Switch security solution (intrusion switch) 	<ul style="list-style-type: none"> New XCC2 offers improved management capabilities Same system management tool with previous generation Silicon-level security solution

Feature	SR645	ThinkSystem SR645 V3	Benefits
Power	<ul style="list-style-type: none"> • 500W, 750W, 1100W, 1800W AC Platinum/Titanium Hot Plug PSU • 1100W -48VDC Platinum general support • 240V HVDC support for PRC customers • Active-Standby mode 	<ul style="list-style-type: none"> • 500W, 750W, 1100W, 1800W AC Platinum/Titanium Hot Plug PSU • 1100W -48VDC Platinum general support • 240V HVDC support for PRC customers • Active-Standby mode 	<ul style="list-style-type: none"> • Multiple PSU offerings to suit the configuration selected • New ErP Lot 9-compliant offerings • Support for Telco customers with -48V requirements

Components and connectors

The following figure shows the front of the SR645 V3.

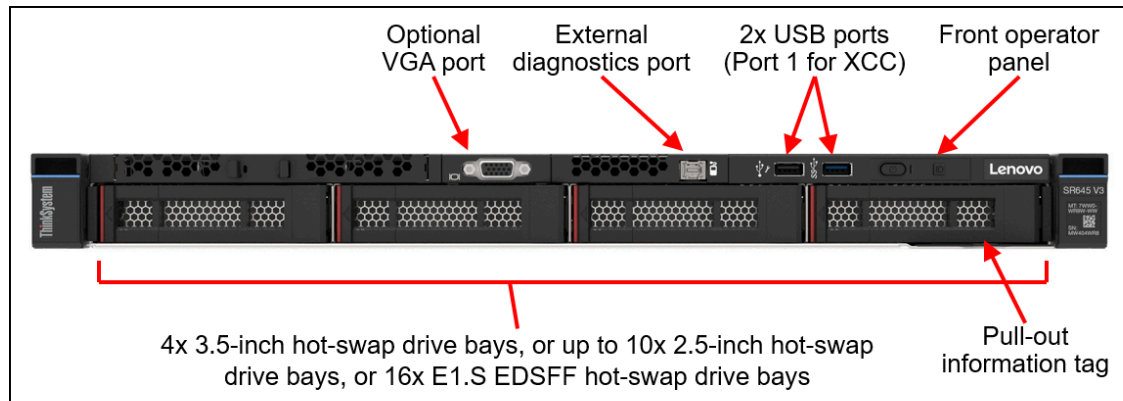

Figure 2. Front view of the ThinkSystem SR645 V3 with 3.5-inch drive bays

For details on the front ports, including the optional front VGA port and front external diagnostic port, see the [Local management](#) section.

The following figure shows the various front configurations supported by the SR645 V3. As shown, the server supports 2.5-inch, 3.5-inch or E1.S EDSFF drive bays. In some configurations, the front of the server includes a pull-out operator panel with LCD display. The SR645 V3 also supports a configuration with 4x 2.5-inch drive bays + 3x front-accessible PCIe slots - a low-profile slot, a full-height slot, and an OCP 3.0 slot.

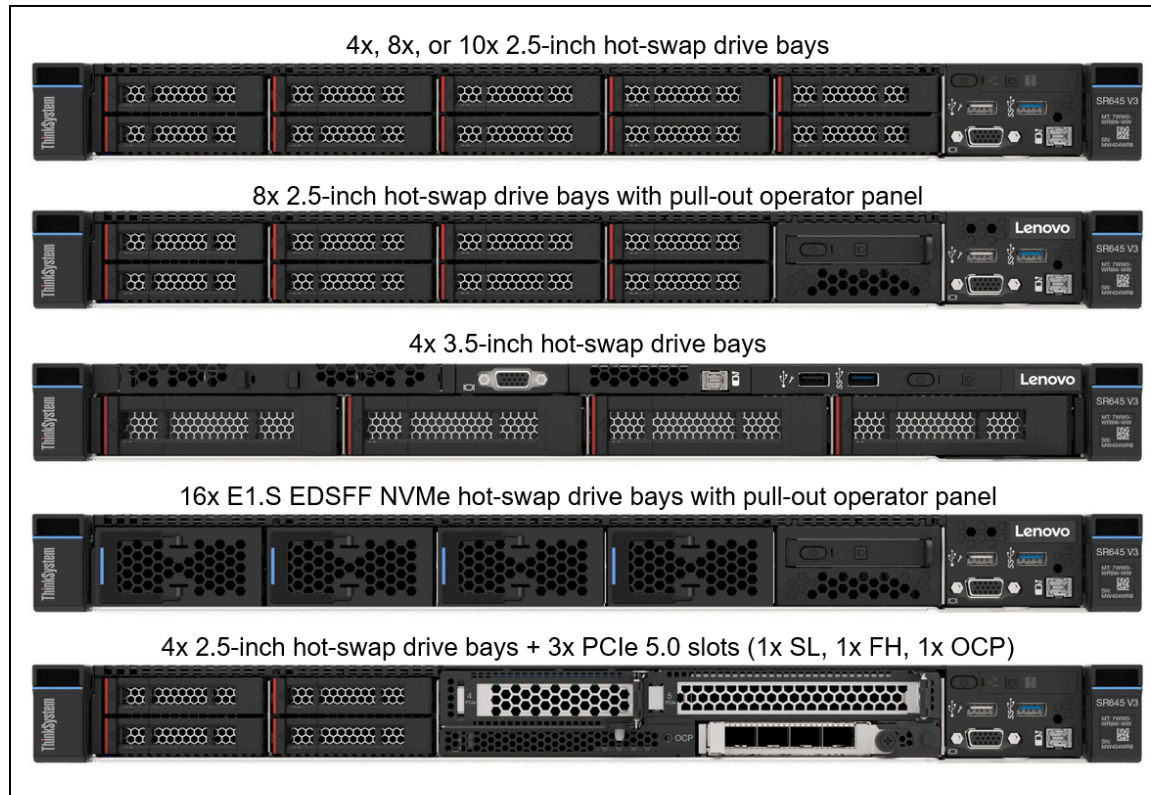

Figure 3. Front configurations of the ThinkSystem SR645 V3

The following figure shows the components visible from the rear of the server. As shown, there are five different configurations available, including two with rear-mounted drive bays: two 2.5-inch hot-swap drive bays (SAS, SATA or NVMe) or 7mm thickness hot-swap drives (SATA or NVMe). There are two configurations with a full-height slot, one where both slots are connected to CPU 1, and the other where the full-height slot is connected to CPU 2.

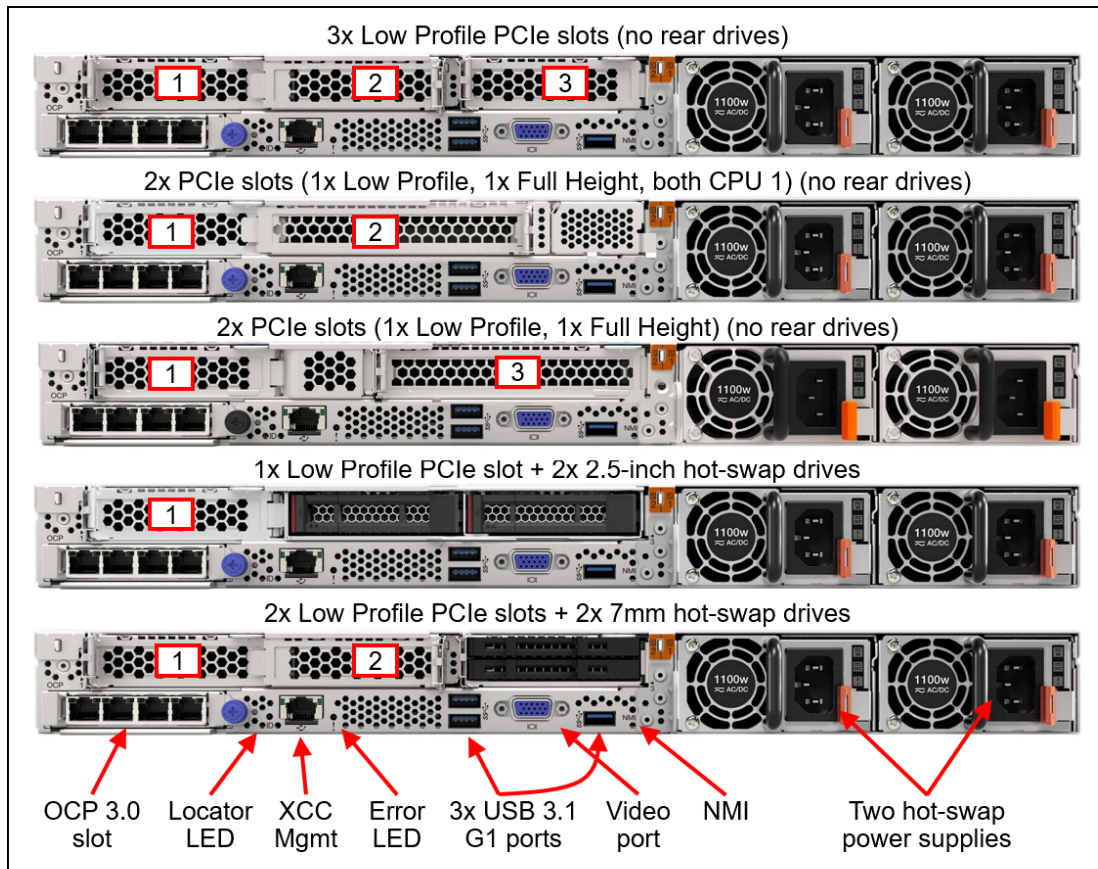

Figure 4. Rear view of the Lenovo ThinkSystem SR645 V3

The following figure shows the locations of key components inside the server.

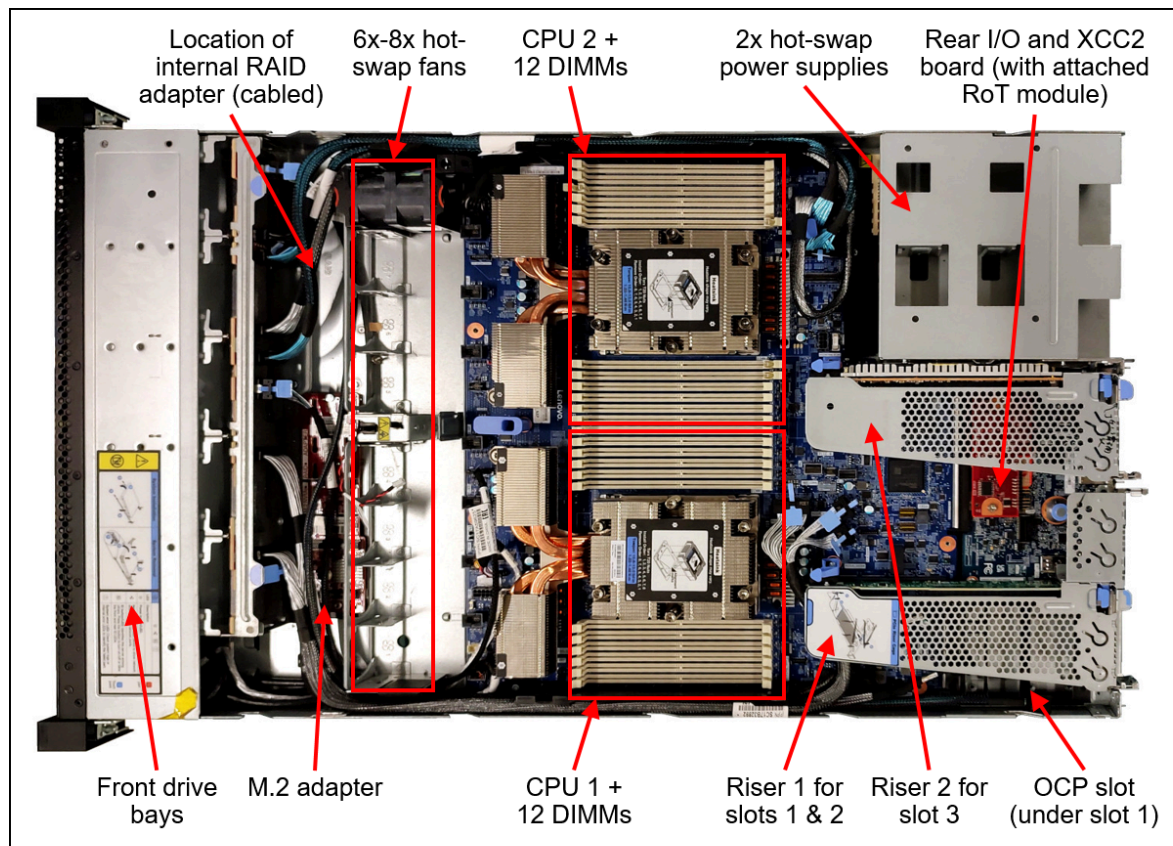

Figure 5. Internal view of the Lenovo ThinkSystem SR645 V3

System architecture

The following figure shows the architectural block diagram of the SR645 V3, showing the major components and their connections.

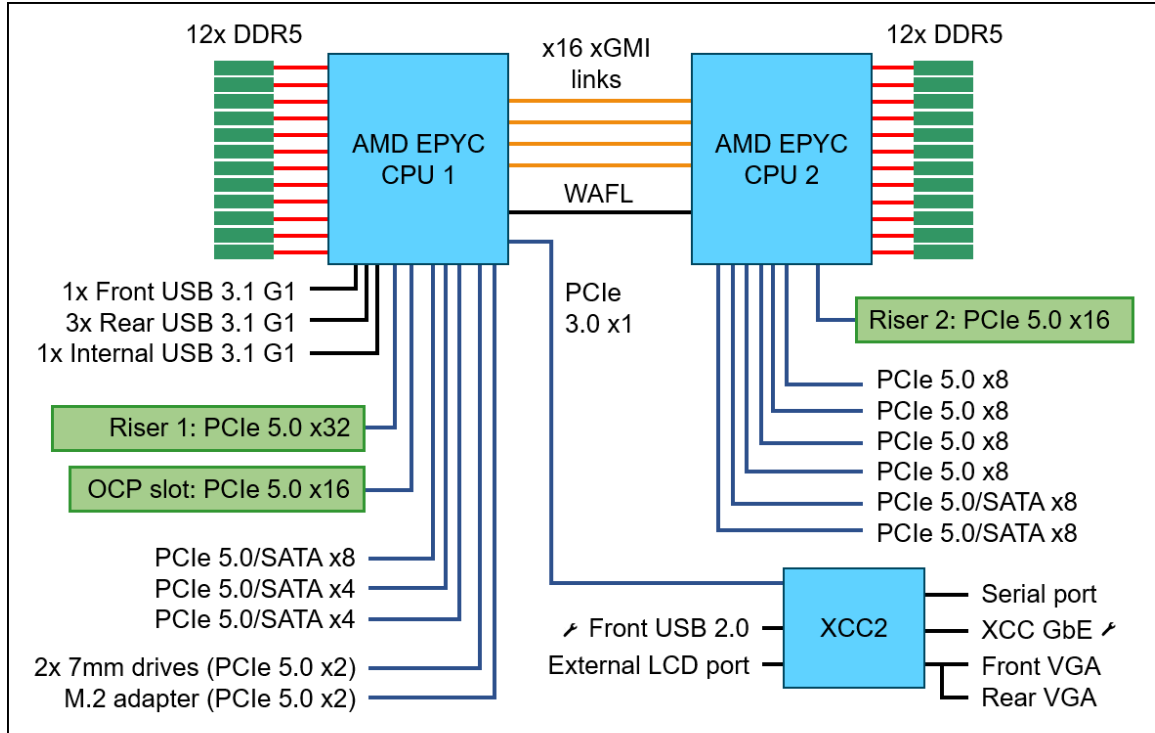

Figure 6. SR645 V3 system architectural block diagram

Standard specifications

The following table lists the standard specifications.

Table 2. Standard specifications

Components	Specification
Machine types	7D9D - 1 year warranty 7D9C - 3 year warranty
Form factor	1U rack.
Processor	One or two AMD EPYC processors, either 5th Gen 9005 ("Turin") or 4th Gen 9004 ("Genoa"). Supports processors up to 160 cores, core speeds of up to 4.1 GHz, and TDP ratings of up to 400W. Supports PCIe 5.0 for high performance I/O.
Chipset	Not applicable (platform controller hub functions are integrated into the processor)
Memory	24 DIMM slots with two processors (12 DIMM slots per processor). Each processor has 12 memory channels, with 1 DIMM per channel (DPC). Lenovo TruDDR5 RDIMMs, 3DS RDIMMs, and 9x4 RDIMMs are supported. Memory speeds up to 6400 MHz with 5th Gen AMD EPYC processors.
Memory maximum	Up to 6TB with 24x 256GB 3DS RDIMMs
Persistent memory	Not supported
Memory protection	ECC, SDDC, Patrol/Demand Scrubbing, Bounded Fault, DRAM Address Command Parity with Replay, DRAM Uncorrected ECC Error Retry, On-die ECC, ECC Error Check and Scrub (ECS), Post Package Repair
Disk drive bays	<p>Up to 4x 3.5-inch or 12x 2.5-inch hot-swap drive bays:</p> <ul style="list-style-type: none"> • Front bays can be one of the following: <ul style="list-style-type: none"> ◦ 4x 3.5-inch hot-swap SAS/SATA, AnyBay, or 2x SAS/SATA + 2x NVMe ◦ 2x 2.5-inch hot-swap NVMe ◦ 4x 2.5-inch hot-swap SAS/SATA, AnyBay or NVMe ◦ 8x 2.5-inch hot-swap SAS/SATA ◦ 10x 2.5-inch hot-swap SAS/SATA, AnyBay or NVMe, or combinations ◦ 16x E1.S hot-swap EDSFF NVMe • Rear can be one of the following: <ul style="list-style-type: none"> ◦ 2x 2.5-inch hot-swap SAS/SATA bays ◦ 2x 2.5-inch hot-swap NVMe bays ◦ 2x 7mm 2.5-inch hot-swap SATA bays ◦ 2x 7mm 2.5-inch hot-swap NVMe bays • Internal M.2 module supporting up to two M.2 drives, for OS boot and drive storage support <p>See Storage configurations for details. AnyBay bays support SAS, SATA or NVMe drives. NVMe bays only support NVMe drives. Rear drive bays can be used in conjunction with 2.5-inch front drive bays. The server supports up to 12x NVMe drives all with direct connections (no oversubscription).</p>

Components	Specification
Maximum internal storage	<ul style="list-style-type: none"> • 2.5-inch drives: <ul style="list-style-type: none"> ◦ 368.64TB using 12x 30.72TB 2.5-inch SAS SSDs ◦ 92.16TB using 12x 7.68TB 2.5-inch SATA SSDs ◦ 1474.56TB using 12x 122.88TB 2.5-inch NVMe SSDs ◦ 28.8TB using 12x 2.4TB 2.5-inch SAS HDDs • EDSFF drives <ul style="list-style-type: none"> ◦ 122.88TB using 16x 7.68TB E1.S EDSFF NVMe SSDs • 3.5-inch drives: <ul style="list-style-type: none"> ◦ 96TB using 4x 24TB 3.5-inch SAS HDDs ◦ 96TB using 4x 24TB 3.5-inch SATA HDDs ◦ 61.44TB using 4x 15.36TB 3.5-inch SAS SSDs ◦ 30.72TB using 4x 7.68TB 3.5-inch SATA SSDs ◦ 51.2TB using 4x 12.8TB 3.5-inch NVMe SSDs
Storage controller	<ul style="list-style-type: none"> • Onboard NVMe (no RAID) - 12 drives, each x4 • Onboard SATA (no RAID) - 12 drives • NVMe Retimer Adapter • 12 Gb SAS/SATA RAID adapters <ul style="list-style-type: none"> ◦ 8, 16 or 32 ports ◦ Up to 8GB flash-backed cache ◦ PCIe 4.0 or PCIe 3.0 host interface • 12 Gb SAS/SATA HBA (non-RAID) <ul style="list-style-type: none"> ◦ 8-port and 16-port ◦ PCIe 4.0 or PCIe 3.0 host interface
Optical drive bays	No internal optical drive
Tape drive bays	No internal backup drive
Network interfaces	Dedicated OCP 3.0 SFF slot with PCIe 5.0 x16 host interface, either at the rear of the server (rear-accessible) or the front of the server (front-accessible, PCIe 4.0). Supports a variety of 2-port and 4-port adapters with 1GbE, 10GbE and 25GbE network connectivity. One port can optionally be shared with the XClarity Controller 2 (XCC2) management processor for Wake-on-LAN and NC-SI support. Additional PCIe network adapters supported in PCIe slots.

Components	Specification
PCI Expansion slots	<p>Up to 5x slots, 3x at the rear and 2x at the front, plus 1 OCP 3.0 slot.</p> <p>Rear: Up to 3x PCIe slots (2x PCIe 5.0, 1x PCIe 4.0), all with rear access, plus a slot dedicated to the OCP adapter. Slot availability is based on riser selection and rear drive bay selection. Slot 3 requires two processors.</p> <p>Four choices for rear-access slots:</p> <ul style="list-style-type: none"> • 3x PCIe x16 low-profile slots • 1x PCIe x16 full-height half-length slot + 1x PCIe x16 low-profile slot • 1x PCIe x16 low-profile slot (also supports 2x rear 2.5-inch drive bays) • 2x PCIe x16 low-profile slot (also supports 2x rear 7mm 2.5-inch drive bays) <p>For 2.5-inch front drive configurations, the server supports the installation of a CFF RAID adapter or HBA in a dedicated area that does not consume any of the PCIe slots.</p> <p>Front: The server also supports slots at the front of the server:</p> <ul style="list-style-type: none"> • 1x PCIe x16 or x8 full-height half-length slot • 1x PCIe x8 low-profile slot • 1x OCP 3.0 slot (mutually exclusive with the OCP slot at the rear) <p>Note: Not all slots are available in a 1-processor configuration. See the I/O expansion for details.</p>
GPU support	Supports up to 5x single-wide GPUs
Ports	<p>Front: 1x USB 3.2 G1 (5 Gb/s) port, 1x USB 2.0 port (also for XCC local management), External diagnostics port, optional VGA port.</p> <p>Rear: 3x USB 3.2 G1 (5 Gb/s) ports, 1x VGA video port, 1x RJ-45 1GbE systems management port for XCC remote management. Optional 2nd XCC remote management port (installs in OCP slot). Optional DB-9 COM serial port (installs in slot 3).</p> <p>Internal: 1x USB 3.2 G1 (5 Gb/s) connector for operating system or license key purposes.</p>
Cooling	Up to 8x N+1 redundant hot swap 40 mm fans, configuration dependent. One fan integrated in each power supply. For high-performance CPUs, the SR645 V3 also offers a closed-loop liquid-cooled heatsink design to more effectively remove heat from the processors. For customers with water infrastructure in their data center, the SR645 V3 also offers Lenovo Neptune Core open-loop water cooling for efficient heat removal.
Power supply	Up to two hot-swap redundant AC power supplies, 80 PLUS Platinum or 80 PLUS Titanium certification. 500 W, 750 W, 1100 W and 1800 W AC options, supporting 220 V AC. 500 W, 750 W and 1100 W options also support 110V input supply. In China only, all power supply options support 240 V DC. Also available is a 1100W power supply with a -48V DC input.
Video	Embedded video graphics with 16 MB memory with 2D hardware accelerator, integrated into the XClarity Controller. Maximum resolution is 1920x1200 32bpp at 60Hz.
Hot-swap parts	Drives, power supplies, and fans.
Systems management	Operator panel with status LEDs. Optional External Diagnostics Handset with LCD display. Models with 8x 2.5-inch front drive bays can optionally support an Integrated Diagnostics Panel. XClarity Controller 2 (XCC2) embedded management based on the ASPEED AST2600 baseboard management controller (BMC). Dedicated rear Ethernet port for XCC2 remote access for management. Optional 2nd redundant XCC2 remote port supported, installs in the OCP slot. XClarity Administrator for centralized infrastructure management, XClarity Integrator plugins, and XClarity Energy Manager centralized server power management. Optional XCC Platinum to enable remote control functions and other features.
Security features	Chassis intrusion switch, Power-on password, administrator's password, Root of Trust module supporting TPM 2.0 and Platform Firmware Resiliency (PFR). Optional lockable front security bezel.

Components	Specification
Operating systems supported	Microsoft Windows Server, Microsoft Windows 10 & 11, Red Hat Enterprise Linux, SUSE Linux Enterprise Server, VMware ESXi, Ubuntu Server. See the Operating system support section for specifics.
Limited warranty	Three-year or one-year (model dependent) customer-replaceable unit and onsite limited warranty with 9x5 next business day (NBD).
Service and support	Optional service upgrades are available through Lenovo Services: 4-hour or 2-hour response time, 6-hour fix time, 1-year or 2-year warranty extension, software support for Lenovo hardware and some third-party applications.
Dimensions	Width: 440 mm (17.3 in.), height: 43 mm (1.7 in.), depth: 773 mm (30.4 in.). See Physical and electrical specifications for details.
Weight	Maximum: 20.2 kg (44.6 lb)

Models

ThinkSystem SR645 V3 models can be configured by using the [Lenovo Data Center Solution Configurator \(DCSC\)](#).

Topics in this section:

- [CTO models](#)
- [CTO models for Windows 10 and Windows 11](#)
- [Base feature codes](#)
- [Preconfigured models](#)

CTO models

ThinkSystem SR645 V3 models can be configured by using the [Lenovo Data Center Solution Configurator \(DCSC\)](#).

Configure-to-order (CTO) models are used to create models with factory-integrated server customizations. For CTO models, two types of base CTO models are available for the SR645 V3 as listed in the columns in the following table:

- General purpose base CTO models are for general business (non-HPC) and is selectable by choosing **General Purpose** mode in DCSC.
- AI and HPC base models are intended for Artificial Intelligence (AI) and High Performance Computing (HPC) configurations and solutions are enabled using the **AI & HPC Hardware - ThinkSystem Hardware** mode in DCSC. These configurations, along with Lenovo EveryScale Solutions, can also be built using [System x and Cluster Solutions Configurator \(x-config\)](#). **Tip:** Some HPC and AI models are not listed in DCSC and can only be configured in x-config.

"For AI" models: The base CTO models listed in the table with "for AI" in the names are the only base models that support high-performance GPUs and accelerators (Controlled GPUs). These models are classified under US Government ECCN regulations and have limited market and customer availability. All other base models do not support high-performance GPUs.

Preconfigured server models may also be available for the SR645 V3, however these are region-specific; that is, each region may define their own server models, and not all server models are available in every region.

The following table lists the base CTO models of the ThinkSystem SR645 V3 server.

Table 3. Base CTO models

Machine Type/Model General purpose	Machine Type/Model for AI and HPC	Description
7D9CCTO1WW	7D9CCTOLWW	ThinkSystem SR645 V3-3yr Warranty
7D9CCTOAWW	7D9CCTOHWW	ThinkSystem SR645 V3-3yr Warranty for AI
7D9DCTO1WW	7D9DCTOLWW	ThinkSystem SR645 V3-1yr Warranty

CTO models for Windows 10 and Windows 11

The SR645 V3 can run Windows 10 and Windows 11, however only a subset of adapters and drives can be installed. For ease of configuration, the following Base CTO models have been announced to assist building a configuration that can be used with the client operating systems. For more information, see the [Windows 10 and Windows 11](#) section.

Table 4. Base CTO models for SR645 V3 with Windows 10 and Windows 11

Machine Type/Model	Description
7D9CCTO2WW	ThinkSystem SR645 V3 Workstation - 3 year Warranty
7D9DCTO2WW	ThinkSystem SR645 V3 Workstation - 1 year Warranty

Base feature codes

Models of the SR645 V3 are defined based on whether the server has 2.5-inch drive bays at the front (called the 10x 2.5" chassis or simply the 2.5-inch chassis) or whether it has 3.5-inch drive bays at the front (called the 3.5-inch chassis). For models with front PCIe slots, the SR645 V3 also offers a separate base feature code.

The feature codes for these chassis bases are as listed in the following table.

Table 5. Chassis base feature codes

Feature code	Description	Top Choice Express	Purpose
BLK3	ThinkSystem V3 1U 4x3.5" Chassis	TCE	3.5-inch drive configurations
BLK4	ThinkSystem V3 1U 10x2.5" Chassis	TCE	2.5-inch drive configurations without front PCIe slots EDSFF drive configurations
BQ7M	ThinkSystem V3 1U 4x2.5" Chassis with Front I/O Module	Not TCE	2.5-inch drive configurations with front PCIe slots

Preconfigured models

The following tables list the available preconfigured models, grouped by region.

- [Models for Asia Pacific region](#)
- [Models for Brazil](#)
- [Models for EMEA region](#)
- [Models for India](#)
- [Models for Latin American countries \(except Brazil\)](#)

Refer to the Specifications section for information about standard features of the server.

Common to all models:

- Power supplies are Platinum unless otherwise stated
- All models include a Toolless Slide Rail Kit

Models for Asia Pacific region

The following table lists the models for the Asia Pacific region: Australia, Bangladesh, Brunei, Hong Kong, India, Japan, Korea, Sri Lanka, Malaysia, New Zealand, Philippines, Singapore, Thailand, Taiwan, Vietnam

Table 6. Models for Asia Pacific markets

Model	AMD EPYC processor†	Memory	RAID	Drive bays	OCP	Slots	Power supply	Fans	Front VGA	Front diag	XCC2	Intru switch
Models with 5th Gen AMD EPYC processors												
7D9CA03DAP	1x 9115 16C 125W 2.6G	1x 32GB 2Rx8	940-8i 4GB	8x 2.5" SAS; Open bay	Open	2x LP Gen4	2x1100W	6x Std	Opt	Yes	Std	Opt

† Processor description: Processor model, number of cores, thermal design power (TDP), core frequency

Models for Brazil

Table 8. Models for Brazil

Model	AMD EPYC processor†	Memory	RAID	Drive bays	OCP	Slots	Power supply	Fans	Front VGA	Front diag	XCC2	Intru switch
Models with 5th Gen AMD EPYC processors												

† Processor description: Processor model, number of cores, thermal design power (TDP), core frequency

Models for EMEA region

Table 9. Models for EMEA region

Model	AMD EPYC processor†	Memory	RAID	Drive bays	OCP	Slots	Power supply	Fans	Front VGA	Front diag	XCC2	Intru switch
Models with 5th Gen AMD EPYC processors												
7D9CA038EA	1x 9135 16C 200W 3.65G	1x 32GB 2Rx8	940-8i 4GB	8x 2.5" SAS; Open bay	Open	LP+FH Gen4	2x750W Titanium	6x Perf	Opt	Yes	Plat	Yes
Models with 4th Gen AMD EPYC processors												
7D9CA02FEA	1x 9124 16C 200W 3.0G	1x 32GB 2Rx8	940-8i 4GB	8x 2.5" SAS; Open bay	Open	2x LP Gen5	1x1100W Titanium	6x Perf	Opt	Yes	Plat	Opt

† Processor description: Processor model, number of cores, thermal design power (TDP), core frequency

Models for India

AP models: Customers in India also have access to the [Asia Pacific region](#) models.

Table 10. Models for India

Model	AMD EPYC processor†	Memory	RAID	Drive bays	OCP	Slots	Power supply	Fans	Front VGA	Front diag	XCC2	Intru switch
Models with 4th Gen AMD EPYC processors												
7D9CA01PSG	1x 9124 16C 200W 3.0G	1x 16GB	Option	Option 2.5"; Open bay	Open	Open	1x750W	6x Std	Opt	Yes	Std	Opt
7D9CA022SG	1x 9124 16C 200W 3.0G	1x 32GB 2Rx8	940-16i 4GB Tri	10x 2.5" Any; Open bay	2-10GbT 57416	LP+FH Gen5	2x1100W	6x Perf	Opt	Yes	Std	Opt

† Processor description: Processor model, number of cores, thermal design power (TDP), core frequency

Models for Latin American countries (except Brazil)

Table 11. Models with a 3-year warranty for Latin American countries (except Brazil)

Model	AMD EPYC processor†	Memory	RAID	Drive bays	OCP	Slots	Power supply	Fans	Front VGA	Front diag	XCC2	Intru switch
Models with 5th Gen AMD EPYC processors												

† Processor description: Processor model, number of cores, thermal design power (TDP), core frequency

Processors

The SR645 V3 supports AMD EPYC processors. The server supports one or two processors.

Topics in this section:

- [Processor options](#)
- [Processor features](#)
- [One-processor configurations](#)
- [Thermal requirements by processor](#)
- [Processor heatsinks for field upgrades \(special use cases\)](#)
- [Lenovo Neptune Liquid to Air Module - Closed-loop liquid cooling](#)
- [Lenovo Processor Neptune Core Module - Open-loop liquid cooling](#)
- [UEFI operating modes](#)
- [Platform Secure Boot](#)

Processor options

The SR645 V3 supports the following processor families:

- 5th Gen AMD EPYC processors (formerly codenamed "Turin"):
 - Processors with Zen 5 architecture, with high per-core performance
 - Processors with Zen 5c architecture, with high core density and best power efficiency
- 4th Gen AMD EPYC processors:
 - 4th Gen AMD EPYC processors (formerly codenamed "Genoa")
 - 4th Gen AMD EPYC processors with AMD 3D V-Cache (formerly codenamed "Genoa-X"), with larger L3 caches, suitable for engineering workloads like EDA and CFD
 - 4th Gen AMD EPYC processors with Zen 4c architecture (formerly codenamed "Bergamo"), with higher core counts, suitable for workloads like cloud-native applications

All supported processors have the following characteristics:

- 12 DDR5 memory channels
- 128 PCIe 5.0 I/O lanes, 64 lanes available for PCIe and NVMe devices

Configuration notes:

- Processor options include a heatsink but do not include a system fan
- Processors with a P suffix are single-socket capable processors and are only available in configure-to-order builds or in preconfigured models. These processors are not available as option part numbers.
- In the SR645 V3, 4th Gen processors with a TDP of 320W or more are only supported with liquid cooling and both processors must be configured. As a result, processors are CTO only and no field upgrades are available.
- All 5th Gen processors support a 6400 MHz memory bus speed provided specific memory DIMMs are installed in the server and the latest system firmware is applied. See the table in the [Memory options](#) section to see which DIMMs support 6400 MHz. For all other DIMMs, the memory bus operates at 6000 MHz.

The following table lists the 5th Gen AMD EPYC processors supported by the SR645 V3. The table includes a Top Choice Express column; for CTO orders, select a TCE component for faster delivery. See the [Top Choice](#) section for more information.

Table 13. 5th Gen AMD EPYC processor support

Part number	Feature code	SKU	Description	Top Choice Express	Quantity supported
5th AMD EPYC processors ("Turin") with Zen 5 architecture					
4XG7B02713	C2AF	9015	ThinkSystem SR645 V3 AMD EPYC 9015 8C 125W 3.6GHz Processor w/o Fan	Not TCE	1 or 2
4XG7B02712	C2AG	9115	ThinkSystem SR645 V3 AMD EPYC 9115 16C 125W 2.6GHz Processor w/o Fan	Not TCE	1 or 2
4XG7B02138	C2AK	9135	ThinkSystem SR645 V3 AMD EPYC 9135 16C 200W 3.65GHz Processor w/o Fan	TCE	1 or 2
CTO only	C2AR	9175F	AMD EPYC 9175F 16C 320W 4.2GHz Processor	Not TCE	2
4XG7B02710	C2AP	9255	ThinkSystem SR645 V3 AMD EPYC 9255 24C 200W 3.25GHz Processor w/o Fan	Not TCE	1 or 2
CTO only	C2AT	9275F	AMD EPYC 9275F 24C 320W 4.1GHz Processor	Not TCE	2
4XG7B02711	C2AQ	9335	ThinkSystem SR645 V3 AMD EPYC 9335 32C 210W 3.0GHz Processor w/o Fan	TCE	1 or 2
4XG7B02137	C2AZ	9355	ThinkSystem SR645 V3 AMD EPYC 9355 32C 280W 3.55GHz Processor w/o Fan	Not TCE	1 or 2
None	C2AV	9355P	AMD EPYC 9355P 32C 280W 3.55GHz Processor	Not TCE	1
4XG7B02709	C2AM	9365	ThinkSystem SR645 V3 AMD EPYC 9365 36C 300W 3.4GHz Processor w/o Fan	Not TCE	1 or 2
CTO only	C2AJ	9375F	AMD EPYC 9375F 32C 320W 3.8GHz Processor	Not TCE	2
4XG7B02708	C2ND	9455	ThinkSystem SR645 V3 AMD EPYC 9455 48C 300W 3.15GHz Processor w/o Fan	Not TCE	1 or 2
None	C2NE	9455P	AMD EPYC 9455P 48C 300W 3.15GHz Processor	Not TCE	1
CTO only	C2A3	9475F	AMD EPYC 9475F 48C 400W 3.65GHz Processor	Not TCE	2
4XG7B02707	C2AL	9535	ThinkSystem SR645 V3 AMD EPYC 9535 64C 300W 2.4GHz Processor w/o Fan	Not TCE	1 or 2
4XG7B02140	C2AY	9555	ThinkSystem SR645 V3 AMD EPYC 9555 64C 360W 3.2GHz Processor w/o Fan	Not TCE	1 or 2
None	C2AW	9555P	AMD EPYC 9555P 64C 360W 3.2GHz Processor	Not TCE	1
4XG7B02718	C2AS	9565	ThinkSystem SR645 V3 AMD EPYC 9565 72C 400W 3.15GHz Processor w/o Fan	Not TCE	1 or 2
CTO only	C4H8	9575F	AMD EPYC 9575F 64C 400W 3.3GHz Processor	Not TCE	2
4XG7B02139	C2AU	9655	ThinkSystem SR645 V3 AMD EPYC 9655 96C 400W 2.6GHz Processor w/o Fan	Not TCE	1 or 2
None	C2AX	9655P	AMD EPYC 9655P 96C 400W 2.6GHz Processor	Not TCE	1
5th AMD EPYC processors ("Turin") with Zen 5c architecture					
4XG7B02717	C2AN	9645	ThinkSystem SR645 V3 AMD EPYC 9645 96C 320W 2.3GHz Processor w/o Fan	Not TCE	1 or 2
4XG7B02715	C2AE	9745	ThinkSystem SR645 V3 AMD EPYC 9745 128C 400W 2.4GHz Processor w/o Fan	Not TCE	1 or 2
4XG7B02716	C2AH	9825	ThinkSystem SR645 V3 AMD EPYC 9825 144C 390W 2.2GHz Processor w/o Fan	Not TCE	1 or 2
4XG7B02714	C2TD	9845	ThinkSystem SR645 V3 AMD EPYC 9845 160C 390W 2.1GHz Processor w/o Fan	Not TCE	1 or 2

The following table lists the 4th Gen AMD EPYC processors supported by the SR645 V3.

Table 14. 4th Gen AMD EPYC processor support

Part number	Feature code	SKU	Description	Top Choice Express	Quantity supported
4th Gen AMD EPYC processors ("Genoa")					
4XG7A85060	BREE	9124	ThinkSystem SR645 V3 AMD EPYC 9124 16C 200W 3.0GHz Processor w/o Fan	TCE	1 or 2
None	BREJ	9174F	AMD EPYC 9174F 16C 320W 4.1GHz Processor	Not TCE	2
4XG7A85057	BREH	9224	ThinkSystem SR645 V3 AMD EPYC 9224 24C 200W 2.5GHz Processor w/o Fan	Not TCE	1 or 2
4XG7A85059	BRED	9254	ThinkSystem SR645 V3 AMD EPYC 9254 24C 200W 2.9GHz Processor w/o Fan	Not TCE	1 or 2
None	BREF	9274F	AMD EPYC 9274F 24C 320W 4.05GHz Processor	Not TCE	2
4XG7A85058	BREC	9334	ThinkSystem SR645 V3 AMD EPYC 9334 32C 210W 2.7GHz Processor w/o Fan	Not TCE	1 or 2
4XG7A87040	BR30	9354	ThinkSystem SR645 V3 AMD EPYC 9354 32C 280W 3.25GHz Processor w/o Fan	Not TCE	1 or 2
None	BREG	9354P	AMD EPYC 9354P 32C 280W 3.25GHz Processor	Not TCE	1
None	BR32	9374F	AMD EPYC 9374F 32C 320W 3.85GHz Processor	Not TCE	2
4XG7A85056	BREB	9454	ThinkSystem SR645 V3 AMD EPYC 9454 48C 290W 2.75GHz Processor w/o Fan	Not TCE	1 or 2
None	BREM	9454P	AMD EPYC 9454P 48C 290W 2.75GHz Processor	Not TCE	1
None	BR31	9474F	AMD EPYC 9474F 48C 360W 3.6GHz Processor	Not TCE	2
4XG7A85055	BREA	9534	ThinkSystem SR645 V3 AMD EPYC 9534 64C 280W 2.45GHz Processor w/o Fan	Not TCE	1 or 2
None	BPVJ	9554	AMD EPYC 9554 64C 360W 3.1GHz Processor	Not TCE	2
4XG7A87041	BR2Z	9634	ThinkSystem SR645 V3 AMD EPYC 9634 84C 290W 2.25GHz Processor w/o Fan	Not TCE	1 or 2
None	BPVK	9654	AMD EPYC 9654 96C 360W 2.4GHz Processor	Not TCE	2
4th AMD EPYC processors with AMD 3D V-Cache ("Genoa-X")					
4XG7A97357	BXFT	9184X	ThinkSystem SR645 V3 AMD EPYC 9184X 16C 320W 3.55GHz Processor	Not TCE	2
4XG7A97356	BW9V	9384X	ThinkSystem SR645 V3 AMD EPYC 9384X 32C 320W 3.1GHz Processor	Not TCE	2
4XG7A90962	BW9U	9684X	ThinkSystem SR645 V3 AMD EPYC 9684X 96C 400W 2.55GHz Processor w/o Fan	Not TCE	2
4th Gen AMD EPYC processors with Zen 4c architecture ("Bergamo")					
None	BW9S	9734	AMD EPYC 9734 112C 340W 2.2GHz Processor	Not TCE	2
None	BW9T	9754	AMD EPYC 9754 128C 360W 2.25GHz Processor	Not TCE	2

Processor features

The following table lists the features of the supported 5th Gen AMD EPYC processors.

6400 MHz memory support: The processors support memory up to 6400 MHz provided that specific memory DIMMs are installed in the server and the latest system firmware is applied. See the table in the [Memory options](#) section to see which DIMMs support 6400 MHz.

Table 15. Processor specifications - 5th Gen AMD EPYC processors

EPYC model**	Cores / Threads	Base Frequency	Max Boost Frequency†	L3 Cache	Memory channels	Memory bus	TDP
5th AMD EPYC processors ("Turin") with Zen 5 architecture							
9015	8 / 16	3.6 GHz	4.1 GHz	64 MB	12	6400 MHz	125W
9115	16 / 32	2.6 GHz	4.4 GHz	64 MB	12	6400 MHz	125W
9135	16 / 32	3.65 GHz	4.3 GHz	64 MB	12	6400 MHz	200W
9175F	16 / 32	4.2 GHz	5 GHz	512 MB	12	6400 MHz	320W
9255	24 / 48	3.25 GHz	4.3 GHz	128 MB	12	6400 MHz	200W
9275F	24 / 48	4.1 GHz	4.8 GHz	256 MB	12	6400 MHz	320W
9335	32 / 64	3 GHz	4.4 GHz	128 MB	12	6400 MHz	210W
9355	32 / 64	3.55 GHz	4.4 GHz	256 MB	12	6400 MHz	280W
9355P	32 / 64	3.55 GHz	4.4 GHz	256 MB	12	6400 MHz	280W
9365	36 / 72	3.4 GHz	4.3 GHz	192 MB	12	6400 MHz	300W
9375F	32 / 64	3.8 GHz	4.8 GHz	256 MB	12	6400 MHz	320W
9455	48 / 96	3.15 GHz	4.4 GHz	256 MB	12	6400 MHz	300W
9455P	48 / 96	3.15 GHz	4.4 GHz	256 MB	12	6400 MHz	300W
9475F	48 / 96	3.65 GHz	4.8 GHz	256 MB	12	6400 MHz	400W
9535	64 / 128	2.4 GHz	4.3 GHz	256 MB	12	6400 MHz	300W
9555	64 / 128	3.2 GHz	4.4 GHz	256 MB	12	6400 MHz	360W
9555P	64 / 128	3.2 GHz	4.4 GHz	256 MB	12	6400 MHz	360W
9565	72 / 144	3.15 GHz	4.3 GHz	384 MB	12	6400 MHz	400W
9575F	64 / 128	3.3 GHz	5 GHz	256 MB	12	6400 MHz	400W
9655	96 / 192	2.6 GHz	4.5 GHz	384 MB	12	6400 MHz	400W
9655P	96 / 192	2.6 GHz	4.5 GHz	384 MB	12	6400 MHz	400W
5th AMD EPYC processors ("Turin") with Zen5c architecture							
9645	96 / 192	2.3 GHz	3.7 GHz	256 MB	12	6400 MHz	320W
9745	128 / 256	2.4 GHz	3.7 GHz	256 MB	12	6400 MHz	400W
9825	144 / 288	2.2 GHz	3.7 GHz	384 MB	12	6400 MHz	390W
9845	160 / 320	2.1 GHz	3.7 GHz	320 MB	12	6400 MHz	390W

† The maximum single-core frequency that the processor is capable of operating

** Processors with a P suffix are single-socket capable processors; Processors with an F suffix are frequency-optimized processor

The following table lists the features of the supported 4th Gen AMD EPYC processors.

Table 16. Processor specifications - 4th Gen AMD EPYC processors

EPYC model**	Cores / Threads	Base Frequency	Max Boost Frequency†	L3 Cache	Memory channels	Memory bus	TDP
4th Gen AMD EPYC processors ("Genoa")							
9124	16 / 32	3.0 GHz	3.7 GHz	64 MB	12	4800 MHz	200W
9174F	16 / 32	4.1 GHz	4.4 GHz	256 MB	12	4800 MHz	320W
9224	24 / 48	2.5 GHz	3.7 GHz	64 MB	12	4800 MHz	200W
9254	24 / 48	2.9 GHz	4.15 GHz	128 MB	12	4800 MHz	200W
9274F	24 / 48	4.05 GHz	4.3 GHz	256 MB	12	4800 MHz	320W

EPYC model**	Cores / Threads	Base Frequency	Max Boost Frequency†	L3 Cache	Memory channels	Memory bus	TDP
9334	32 / 64	2.7 GHz	3.9 GHz	128 MB	12	4800 MHz	210W
9354	32 / 64	3.25 GHz	3.8 GHz	256 MB	12	4800 MHz	280W
9354P	32 / 64	3.25 GHz	3.8 GHz	256 MB	12	4800 MHz	280W
9374F	32 / 64	3.85 GHz	4.3 GHz	256 MB	12	4800 MHz	320W
9454	48 / 96	2.75 GHz	3.8 GHz	256 MB	12	4800 MHz	290W
9454P	48 / 96	2.75 GHz	3.8 GHz	256 MB	12	4800 MHz	290W
9474F	48 / 96	3.6 GHz	4.1 GHz	256 MB	12	4800 MHz	360W
9534	64 / 128	2.45 GHz	3.7 GHz	256 MB	12	4800 MHz	280W
9554	64 / 128	3.1 GHz	3.75 GHz	256 MB	12	4800 MHz	360W
9634	84 / 168	2.25 GHz	3.7 GHz	384 MB	12	4800 MHz	290W
9654	96 / 192	2.4 GHz	3.7 GHz	384 MB	12	4800 MHz	360W
4th AMD EPYC processors with AMD 3D V-Cache ("Genoa-X")							
9184X	16 / 32	3.55 GHz	4.20 GHz	768 MB	12	4800 MHz	320W
9384X	32 / 64	3.1 GHz	3.9 GHz	768 MB	12	4800 MHz	320W
9684X	96 / 192	2.55 GHz	3.7 GHz	1150 MB	12	4800 MHz	400W
4th Gen AMD EPYC processors with Zen 4c architecture ("Bergamo")							
9734	112 / 224	2.2 GHz	3.0 GHz	256 MB	12	4800 MHz	340W
9754	128 / 256	2.25 GHz	3.2 GHz	256 MB	12	4800 MHz	360W

† The maximum single-core frequency that the processor is capable of operating

** Processors with a P suffix are single-socket capable processors; Processors with an F suffix are frequency-optimized processor

One-processor configurations

The SR645 V3 can be used with only one processor installed. Most core functions of the server (including the XClarity Controller) are connected to processor 1 as shown in the [System architecture](#) section.

With only one processor, the server has the following capabilities:

- 12 memory DIMMs
- Slot 1 and Slot 2 are available; Slot 3 is not available

Drive support and controller support is as listed in the [Storage configurations](#) section - see the CPUs column in the tables for the configurations that support 1 processor.

Thermal requirements by processor

For thermal requirements for processors, see the Thermal Rules section in the Lenovo Docs site for the SR645 V3:

https://pubs.lenovo.com/sr645-v3/thermal_rules

The SR645 V3 supports three different processor cooling solutions, depending on the configuration, as listed in the following table.

Table 17. Processor cooling options

Feature code	Description	Purpose
BQ26	ThinkSystem SR645 V3/SR635 V3 1U High Performance Heatsink (Neptune Thermal Transfer Module)	Performance 1U heatsink with two satellite heatsinks. Automatically selected based on the server configuration.
BS34	ThinkSystem SR645 V3 Neptune Liquid to Air Module	Enables closed-loop liquid cooling of the processors. See the Lenovo Neptune Liquid to Air Module section.
BZGM	ThinkSystem V3 Neptune Processor Direct Water Cooling Solution	Enables open-loop liquid cooling of the processors. See the Lenovo Neptune Processor DWC Module section.

Processor heatsinks for field upgrades (special use cases)

Processor options include a heatsink that best matches that processor's power dissipation, so no additional heatsink is required to install the processor option in the server. However, in very rare cases for some configurations, a different heatsink is required. Examples of this may be a customer who obtained a sample processor for evaluation from a processor vendor.

The following table lists the available heatsink part numbers for internal ordering.

Internal ordering only: These part numbers can only be ordered by employees using an internal ordering process.

Table 18. Processor heatsink options

Part number	Description
4H47A87832	ThinkSystem SR645 V3 1U Liquid to Air Heatsink
4H47A87833	ThinkSystem V3 1U High Performance Heatsink

Lenovo Neptune Liquid to Air Module - Closed-loop liquid cooling

The Lenovo Neptune Liquid to Air (L2A) Module is a closed-loop liquid-cooled processor heatsink, and is primarily used for processors with a high TDP.

The use of the closed-loop heatsink allows the following configurations that the performance heatsink cannot support:

- 9384X/9184X/9274F/9374F/9474F processors in the 2.5-inch chassis
- 9684X processors with a 8x2.5-inch or 10x2.5-inch front drive backplane
- 9734/9754 processors with a 10x2.5-inch front drive backplane
- Support for up to 30°C ambient for all Group E processors (320W ≤ TDP ≤ 400W)

The following figure shows the placement of the components in the closed-loop liquid-cooled solution. Cold plates are mounted on top of each processor and these are connected via aluminum tubes to a radiator that is placed in front of the system fans. The tubes contain a mixture of water and ethylene glycol (EGW). The liquid is actively pumped through the pipes in a closed loop to remove the heat from the processors.

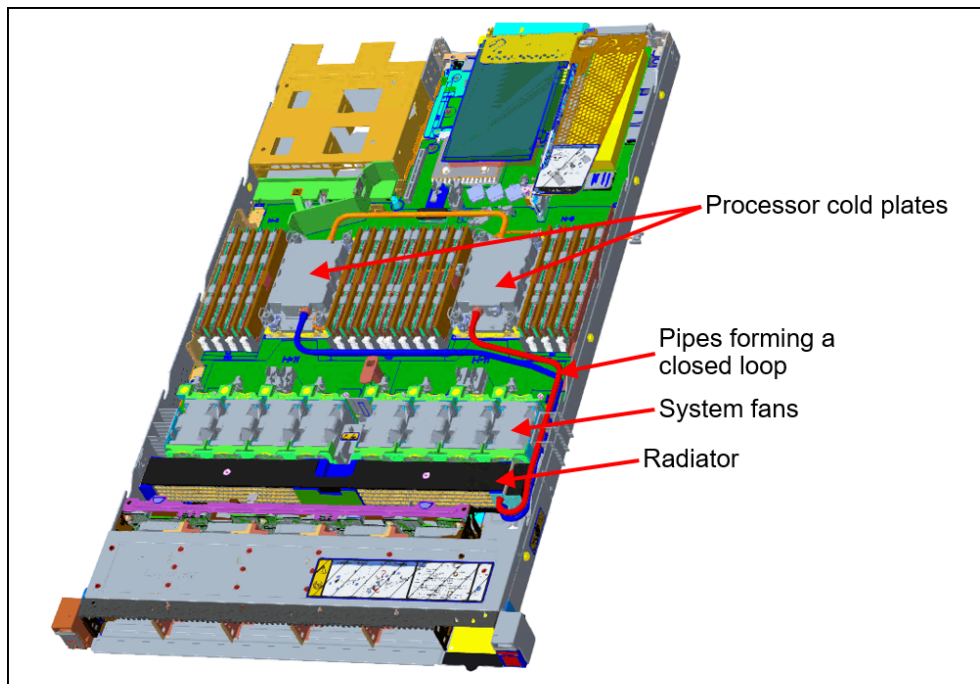

Figure 7. SR645 V3 with closed water loop (feature BS34)

The Neptune Liquid to Air Module is only available in CTO orders, not as a field upgrade. Ordering information is listed in the following table.

Table 19. Ordering information

Part number	Feature code	Description
CTO only	BS34*	ThinkSystem SR645 V3 Neptune Liquid to Air Module

* In DCSC, this feature code is listed in the Processor tab

The closed-loop liquid-cooled heatsink has the following requirements:

- Two CPUs are required (any TDP)
- Performance fans are required

- One of the following 2.5-inch front drive bay configurations:
 - 10x 2.5-inch SAS/SATA
 - 10x 2.5-inch NVMe Gen4
 - 6x SAS/SATA + 2x AnyBay + 2x NVMe
 - 6x SAS/SATA + 4x AnyBay
 - 8x 2.5-inch SAS/SATA
 - 4x 2.5-inch SAS/SATA
 - 4x 2.5-inch NVMe
 - Configurations without a front drive backplane
- The following drive bay configurations are not supported:
 - 10x 2.5-inch NVMe Gen5
 - 10x 2.5-inch AnyBay Gen4
 - 10x 2.5-inch AnyBay Gen5
 - 3.5-inch drive bays
 - EDSFF drive bays
- If a RAID 940 or 9350 adapter is configured:
 - RAID supercap must be installed in slot 3
 - 7mm drives
- The following components are not supported:
 - 256GB 3DS RDIMMs
 - Rear 2.5-inch drives
 - M.2 adapter
 - Front PCIe slots
 - 7mm SATA
 - Any internal RAID/HBAs (CFF form factor)

For more information, see the Thermal Rules page:

https://pubs.lenovo.com/sr645-v3/thermal_rules

Additional ambient temperature restrictions may apply. See the [Operating environment](#) section for details.

Lenovo Processor Neptune Core Module - Open-loop liquid cooling

The SR645 V3 also supports advanced direct-water cooling (DWC) capability with the Lenovo Processor Neptune Core Module. This module implements a liquid cooling solution where heat from the processors is removed from the rack and the data center using an open loop and coolant distribution units.

With the Processor Neptune Core Module, all heat generated by the processors is removed from the server using water. This means that the server fans and data center air conditioning units only need to remove the heat generated by the other components. This results in lower air conditioning costs and it enables the use of slower fans which results in lower overall power consumption.

The following figure shows the Lenovo Processor Neptune Core Module.

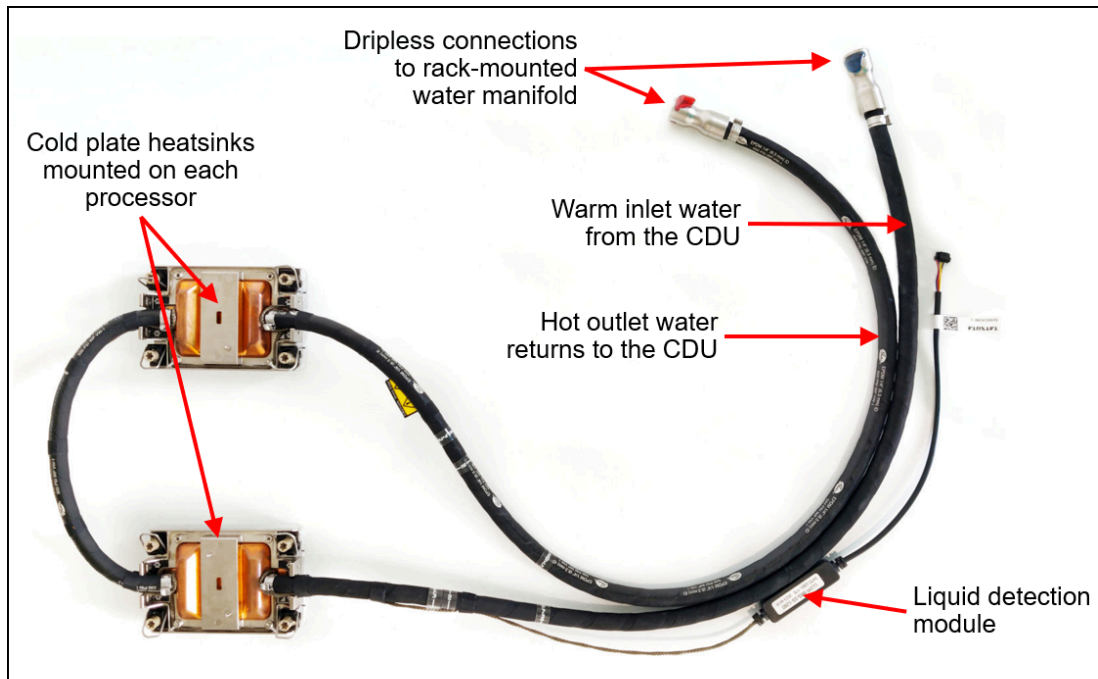

Figure 8. Lenovo Processor Neptune Core Module

The Processor Neptune Core Module also includes a leak detection module which can detect a leakage of more than 0.5ml (about 10 drops) along the length of the tube and then issue an event to the XClarity Controller. XCC will then post an error to the System Event Log and enable further actions. Once the liquid evaporates, a further event is issue to XCC.

The Processor Neptune Core Module is only available in CTO orders, not as a field upgrade. Ordering information is listed in the following table.

Table 20. Lenovo Processor Neptune Core Module

Part number	Feature code	Description	Top Choice Express
CTO only	BZGM*	ThinkSystem SR665 V3/SR645 V3 Processor Neptune Core Module	Not TCE

* In DCSC, this feature code is listed in the Processor tab

Configuration notes:

- The Processor Neptune Core Module requires water infrastructure be available in the rack cabinet and data center, as described in the [Water infrastructure](#) section.
- All processor SKUs are supported
- Two CPUs are required; Configurations with one processor are not supported
- All front drive bay configurations are supported
- Slot 2 is not available for adapters - the water loop is routed through the space otherwise occupied by slot 2
- Only the following slot configurations are supported:
 - 2x Low profile x16 slots, in slot 1 and slot 3
 - 1x Low profile x16 slot in slot 1, and 2x 7mm drives in slot 3
- Rear 2.5-inch drive bays are not supported

- RAID flash power module (supercap) support is limited only to positions 1 (2.5-inch drives only) or position 3 (slot 3), as described in the [RAID flash power module \(supercap\) support](#) section. Location 2 on the air baffle is not supported.
- M.2 adapters are supported based on the configurations in the [Storage configurations](#) section
- Standard fans can be configured in most configurations
- The use of a cable management arm (CMA) is not supported

For more information, see the Thermal Rules page:

https://pubs.lenovo.com/sr645-v3/thermal_rules

The following figure shows the Lenovo Neptune Processor DWC Module installed in the SR645 V3.

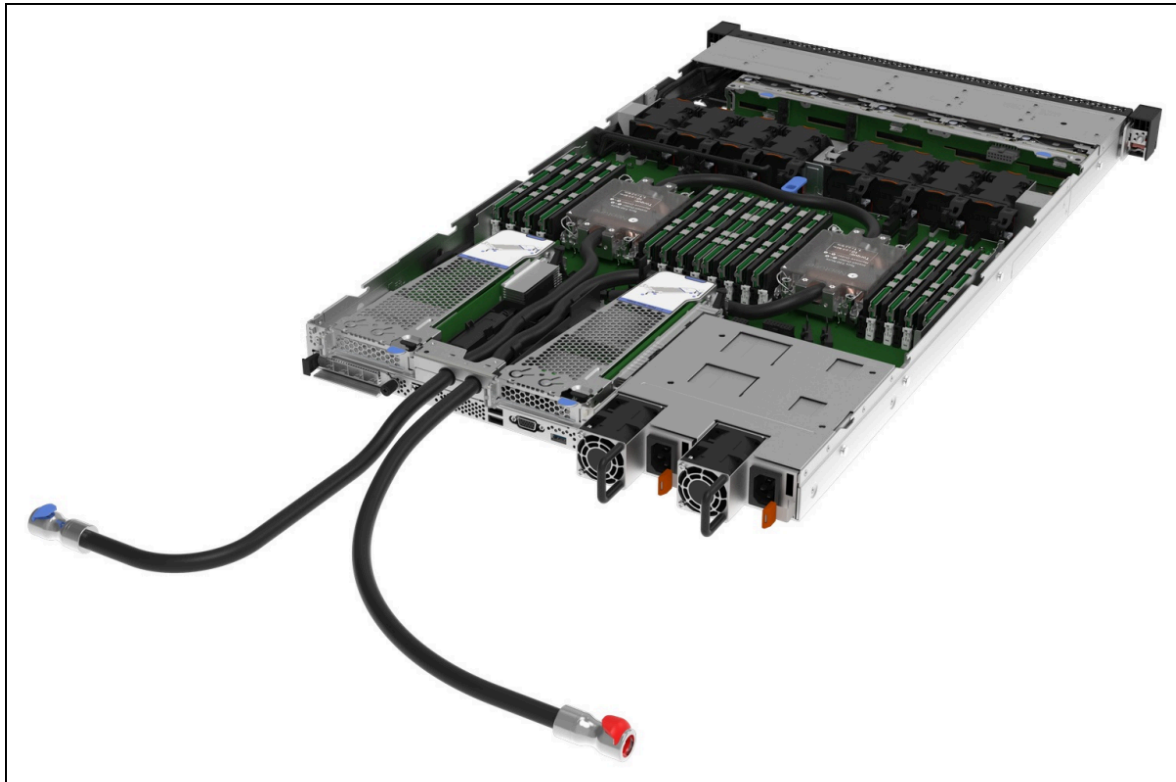

Figure 9. Lenovo Neptune Processor DWC Module installed in the SR645 V3

UEFI operating modes

The SR645 V3 offers preset operating modes that affect energy consumption and performance. These modes are a collection of predefined low-level UEFI settings that simplify the task of tuning the server to suit your business and workload requirements.

The following table lists the feature codes that allow you to specify the mode you wish to preset in the factory for CTO orders.

UK and EU customers: For compliance with the ERP Lot9 regulation, you should select feature BFYA. For some systems, you may not be able to make a selection, in which case, it will be automatically derived by the configurator.

Table 21. UEFI operating mode presets in DCSC

Feature code	Description	Top Choice Express
BFYA	Operating mode selection for: "Maximum Efficiency Mode"	TCE
BFYB	Operating mode selection for: "Maximum Performance Mode"	TCE

The preset modes for the SR645 V3 are as follows:

- **Maximum Efficiency Mode** (feature BFYA): Maximizes performance/watt efficiency while maintaining reasonable performance
- **Maximum Performance Mode** (feature BFYB): Achieves maximum performance but with higher power consumption and lower energy efficiency.

For details about these preset modes, and all other performance and power efficiency UEFI settings offered in the SR645 V3, see the paper "Tuning UEFI Settings for Performance and Energy Efficiency on AMD Processor-Based ThinkSystem Servers", available from <https://lenovopress.lenovo.com/lp1267>.

Platform Secure Boot

Platform Secure Boot (PSB) is a feature of AMD EPYC processors that helps defend against threats to firmware. It is designed to provide protection in response to growing firmware-level remote attacks being seen across the industry. AMD Secure Boot extends the AMD silicon root of trust to help protect the system by establishing an unbroken chain of trust from the AMD silicon root of trust to the BIOS. The UEFI secure boot helps continue the chain of trust from the system BIOS to the OS Bootloader. This feature helps defend against remote attackers seeking to embed malware into firmware.

With PSB enabled, the processor is cryptographically bound to the server firmware code signing key once the processors are installed in the server and the server is powered on. From that point on, that processor can only be used with motherboards that use the same code signing key.

Disabling PSB will stop the protection against remote and local attackers seeking to embed malware into a platform's firmware, BIOS and even UEFI functions. Disabling PSB also allows you to install the processor in another server that you purchased from Lenovo, however, we do not recommend you do this by yourself. Please contact the Lenovo service team for further assistance.

By default, the server has Platform Secure Boot enabled on the installed processors, however for factory orders, you can choose to have the server with PSB disabled. To do this, select feature code C18D as listed in the following table. PSB can be later enabled in System Setup if desired.

Cannot be disabled once enabled: Once you enable PSB in a server, it cannot be disabled on those processors.

Table 22. Platform Secure Boot

Feature code	Description	Purpose
C0DF	Platform Secure Boot Enable	PSB is enabled in the factory and cannot later be disabled. Default choice in DCSC.
C18D	Platform Secure Boot Disable	PSB is not enabled in the factory. It can be later enabled in UEFI System Setup if desired.

If you add a second processor as a field upgrade and your server has PSB enabled, then as soon as you install the processor and power the server on, the processor is then cryptographically bound to the server, and can only be used in that server going forward.

Note: Platform Secure Boot (PSB) is different from the Secure Boot security feature described in the [Platform Firmware Resiliency](#) section.

Memory options

The SR645 V3 uses Lenovo TruDDR5 memory operating at up to 6400 MHz with 5th Gen AMD EPYC processors, and up to 4800 MHz with 4th Gen AMD EPYC processors. The server supports up to 24 DIMMs with 2 processors. The processors have 12 memory channels and support 1 DIMM per channel. The server supports up to 6TB of memory using 24x 256GB 3DS RDIMMs and two processors.

Lenovo TruDDR5 memory uses the highest quality components that are sourced from Tier 1 DRAM suppliers and only memory that meets the strict requirements of Lenovo is selected. It is compatibility tested and tuned to maximize performance and reliability. From a service and support standpoint, Lenovo TruDDR5 memory automatically assumes the system warranty, and Lenovo provides service and support worldwide.

The following table lists the memory options supported in the SR645 V3 with 5th Gen AMD EPYC processors.

The table includes a Top Choice Express column; for CTO orders, select a TCE component for faster delivery. See the [Top Choice](#) section for more information.

Table 23. Memory options for 5th Gen AMD EPYC processors

Part number	Feature code	Description	Top Choice Express	Maximum speed	DRAM technology
x4 RDIMMs					
4X77B09790	CBNB	ThinkSystem SR645 V3/SR665 V3 32GB TruDDR5 6400MHz (1Rx4) RDIMM-A v2	TCE ⓘ	6400 MHz	16Gb
4X77B09788	CBND	ThinkSystem SR645 V3/SR665 V3 64GB TruDDR5 6400MHz (2Rx4) RDIMM-A v2	TCE ⓘ	6400 MHz	16Gb
4X77B07424	CA1Q	ThinkSystem 96GB TruDDR5 6400MHz (2Rx4) RDIMM-A v2	Not TCE	6400 MHz	24Gb
4X77B07421	CA1M	ThinkSystem 128GB TruDDR5 6400MHz (2Rx4) RDIMM-A v2	Not TCE	6400 MHz	32Gb
x8 RDIMMs					
4X77B10304	CC0A	ThinkSystem SR645 V3/SR665 V3 16GB TruDDR5 6400MHz (1Rx8) RDIMM-A v2	Not TCE	6400 MHz	16Gb
4X77B09789	CBNC	ThinkSystem SR645 V3/SR665 V3 32GB TruDDR5 6400MHz (2Rx8) RDIMM-A v2	TCE ⓘ	6400 MHz	16Gb
10x4 3DS RDIMMs					
4X77B07422	CA1N	ThinkSystem 256GB TruDDR5 6400MHz (4Rx4) 3DS RDIMM-A	Not TCE	6400 MHz	32Gb

The following table lists the memory options supported in the SR645 V3 with 4th Gen AMD EPYC processors.

Table 24. Memory options for 4th Gen AMD EPYC processors

Part number	Feature code	Description	Top Choice Express	Maximum speed	DRAM technology
10x4 RDIMMs					
4X77A81438	BQ39	ThinkSystem 32GB TruDDR5 4800MHz (1Rx4) 10x4 RDIMM-A	Not TCE	4800 MHz	16Gb

Part number	Feature code	Description	Top Choice Express	Maximum speed	DRAM technology
4X77A81441	BQ3D	ThinkSystem 64GB TruDDR5 4800MHz (2Rx4) 10x4 RDIMM-A	TCE	4800 MHz	16Gb
4X77A81448	BUVV	ThinkSystem 96GB TruDDR5 4800MHz (2Rx4) 10x4 RDIMM-A	Not TCE	4800 MHz	24Gb
4X77A96982	C467	ThinkSystem 128GB TruDDR5 5600MHz (2Rx4) RDIMM-A	Not TCE	4800 MHz	32Gb
x8 RDIMMs					
4X77A81437	BQ3C	ThinkSystem 16GB TruDDR5 4800MHz (1Rx8) RDIMM-A	TCE ⓘ	4800 MHz	16Gb
4X77A81440	BQ37	ThinkSystem 32GB TruDDR5 4800MHz (2Rx8) RDIMM-A	TCE	4800 MHz	16Gb

For more information on DDR5 memory, see the Lenovo Press paper, *Introduction to DDR5 Memory*, available from <https://lenovopress.com/lp1618>.

The following rules apply when selecting the memory configuration:

- Memory rated at 4800 MHz is only supported with 4th Gen processors. Memory rated at 6400 MHz memory is only supported with 5th Gen processors (and operates at 6000 MHz or 6400 MHz as indicated in the table).
- The SR645 V3 supports quantities 1, 2, 4, 6, 8, 10, 12 DIMMs per processor; other quantities not supported
- The server supports four types of DIMMs: 9x4 RDIMMs, 10x4 RDIMMs, x8 RDIMMs and 3DS RDIMMs
 - UDIMMs and LRDIMMs are not supported
- Mixing of DIMM types is not supported (for example, 9x4 DIMMs with 10x4 RDIMMs)
- Mixing of DRAM technology (16Gb, 24Gb, 32Gb) is not supported. See the column in the above table.
- Mixing of 128GB 3DS RDIMMs and 256GB 3DS RDIMMs is not supported
- Mixing of 128GB 3DS RDIMMs (features BYEE and BQ3A) is not supported
- Mixing of 256GB 3DS RDIMMs (features BZPN and BQ3B) is not supported
- Mixing x4 and x8 DIMMs is not supported
- Mixing of DIMM rank counts is supported. Follow the required installation order installing the DIMMs with the higher rank counts first.
- Mixing of DIMM capacities is supported, however only two different capacities are supported across all channels of the processor (eg 16GB and 32GB). Follow the required installation order installing the larger DIMMs first.
- Memory operates at the speed of the memory bus of the processor (see the [Processor features](#) section for specifics), or the maximum speed that the memory DIMMs support (see the above tables), whichever is lower
- The use of the 128GB 3D RDIMM feature BYEE has the following requirements for thermal reasons:
 - Performance fans are required
 - Rear 2.5-inch drives are not supported
 - GPUs are not supported
 - Additional ambient temperature requirements - see https://pubs.lenovo.com/sr645-v3/thermal_rules for information

Note: Memory mirroring and memory rank sparing are not supported.

For best performance, consider the following:

- Ensure the memory installed is at least the same speed as the memory bus of the selected processor.
- Populate all 12 memory channels with identical DIMMs (same Lenovo part number)

The following memory protection technologies are supported:

- ECC detection/correction
- Bounded Fault detection/correction
- SDDC (for x4-based memory DIMMs; look for "x4" in the DIMM description. Not supported with 9x4 RDIMMs)
- Patrol/Demand Scrubbing
- DRAM Address Command Parity with Replay
- DRAM Uncorrected ECC Error Retry
- On-die ECC
- ECC Error Check and Scrub (ECS)
- Post Package Repair

Internal storage

The SR645 V3 supports 4x 3.5-inch or 12x 2.5-inch or 16x EDSFF drive bays, depending on the selected chassis and backplane configuration. The server also supports configurations without any drive bays if desired.

The two drive bay zones are as follows:

- Front:
 - 4x 3.5-inch hot-swap bays, or
 - Up to 10x 2.5-inch hot-swap bays, or
 - 16x EDSFF hot-swap bays
- Rear:
 - 2x 2.5-inch hot-swap bays, or
 - 2x 7mm hot-swap drives bays

All drives are hot-swap and are accessible from the front or from the rear.

The server also supports one or two M.2 drives, installed in an M.2 adapter internal to the server.

In this section:

- [NVMe drive support](#)
- [Tri-Mode support - RAID 940 adapters](#)
- [Front drive bays](#)
- [Rear 2.5-inch and 7mm drive bays](#)
- [7mm and M.2 supported combinations](#)
- [Storage configurations](#)
- [Field upgrades](#)
- [RAID flash power module \(supercap\) support](#)
- [M.2 drives](#)
- [SED encryption key management with SKLM](#)

NVMe drive support

The SR645 V3 supports NVMe drives to maximize storage performance:

- In 2.5-inch front drive configurations, the server supports up to 12 NVMe drives without oversubscription (that is, each x4 drive has a dedicated x4 connection (4 lanes) to the processor):
 - 10x 2.5-inch NVMe drives at the front
 - 2x 2.5-inch NVMe drives at the rear
- In 3.5-inch front drive configurations, the server supports up to 6 NVMe drives without oversubscription:
 - 4x 3.5-inch NVMe drives at the front
 - 2x 2.5-inch NVMe drives at the rear
- In EDSFF front drive configurations, the server supports up to 16 NVMe drives without oversubscription:
 - 16x E1.S NVMe drives at the front

The specifics of these configurations are covered in the [Storage configurations](#) section.

In addition, the SR645 V3 supports two 7mm NVMe drives for use as boot drives.

Tri-Mode support - RAID 940 adapters

The RAID 940 adapters support NVMe through a feature named Tri-Mode support (or Trimode support). This feature enables the use of NVMe U.3 drives at the same time as SAS and SATA drives. Tri-Mode requires an AnyBay backplane. Cabling of the controller to the backplanes is the same as with SAS/SATA drives, and the NVMe drives are connected via a PCIe x1 link to the controller.

NVMe drives connected using Tri-Mode support provide better performance than SAS or SATA drives: A SATA SSD has a data rate of 6Gbps, a SAS SSD has a data rate of 12Gbps, whereas an NVMe U.3 Gen 4 SSD with a PCIe x1 link will have a data rate of 16Gbps. NVMe drives typically also have lower latency and higher IOPS compared to SAS and SATA drives. Tri-Mode is supported with U.3 NVMe drives and requires an AnyBay backplane.

Tri-Mode requires U.3 drives: Only NVMe drives with a U.3 interface are supported. U.2 drives are not supported. See the [Internal drive options](#) section for the U.3 drives supported by the server.

Front drive bays

The front drive bay zone supports the following configurations. All drives are hot-swap.

- 3.5-inch hot-swap drive bays
 - 4x SAS/SATA 3.5-inch
 - 4x AnyBay 3.5-inch (PCIe Gen4)
 - 2x SATA + 2x SATA/NVMe 3.5-inch (PCIe Gen4)
- 2.5-inch hot-swap drive bays without support for front PCIe slots
 - 4x SAS/SATA
 - 4x NVMe (PCIe Gen4 or Gen5)
 - 8x SAS/SATA
 - 10x SAS/SATA
 - 6x SAS/SATA + 4x AnyBay (PCIe Gen4 or Gen5)
 - 6x SAS/SATA + 2x AnyBay + 2x NVMe (PCIe Gen4 or Gen5)
 - 10x AnyBay (PCIe Gen4 or Gen5)
 - 10x NVMe (PCIe Gen4 or Gen5)
- 2.5-inch hot-swap drive bays with support for front PCIe slots
 - 2x NVMe (PCIe Gen4)
 - 4x NVMe (PCIe Gen4 or Gen5)
 - 4x AnyBay (PCIe Gen5)
- EDSFF drive bays
 - 16x E1.S (9.5mm or 15mm) hot-swap NVMe drive bays (PCIe Gen4)
- Drive-less 2.5-inch configuration - No backplane and no drives (supports [field upgrades](#))
- Drive-less 3.5-inch configuration - No backplane and no drives (supports [field upgrades](#))

These configurations are shown in the following three figures. The feature codes listed correspond to the feature codes listed in the table below the figures.

The following figure shows the supported 3.5-inch drive bay configurations.

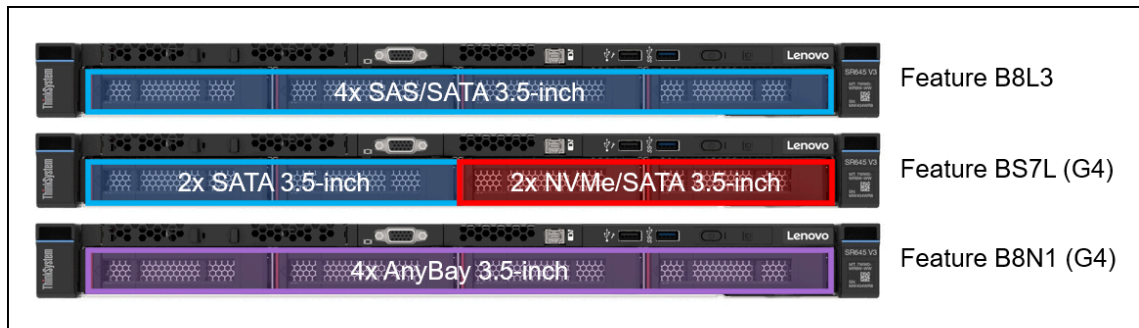

Figure 10. SR645 V3 front drive bay configurations - 3.5-inch drive bays

The following figure shows the supported E1.S EDSFF drive bay configuration. EDSFF drive configurations can be configured with or without an Integrated Diagnostics Panel with pull-out LCD display. See the [Local management](#) section for details.

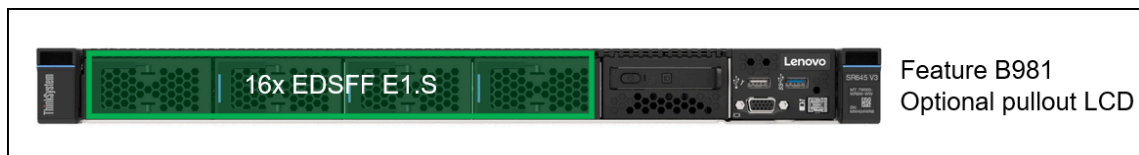

Figure 11. SR645 V3 front drive bay configurations - EDSFF E1.S drive bays

The following figure shows the supported 2.5-inch drive bays drive bay configurations without PCIe slot support.

8x 2.5-inch drive configurations can be configured with or without an Integrated Diagnostics Panel with pull-out LCD display. See the [Local management](#) section for details.

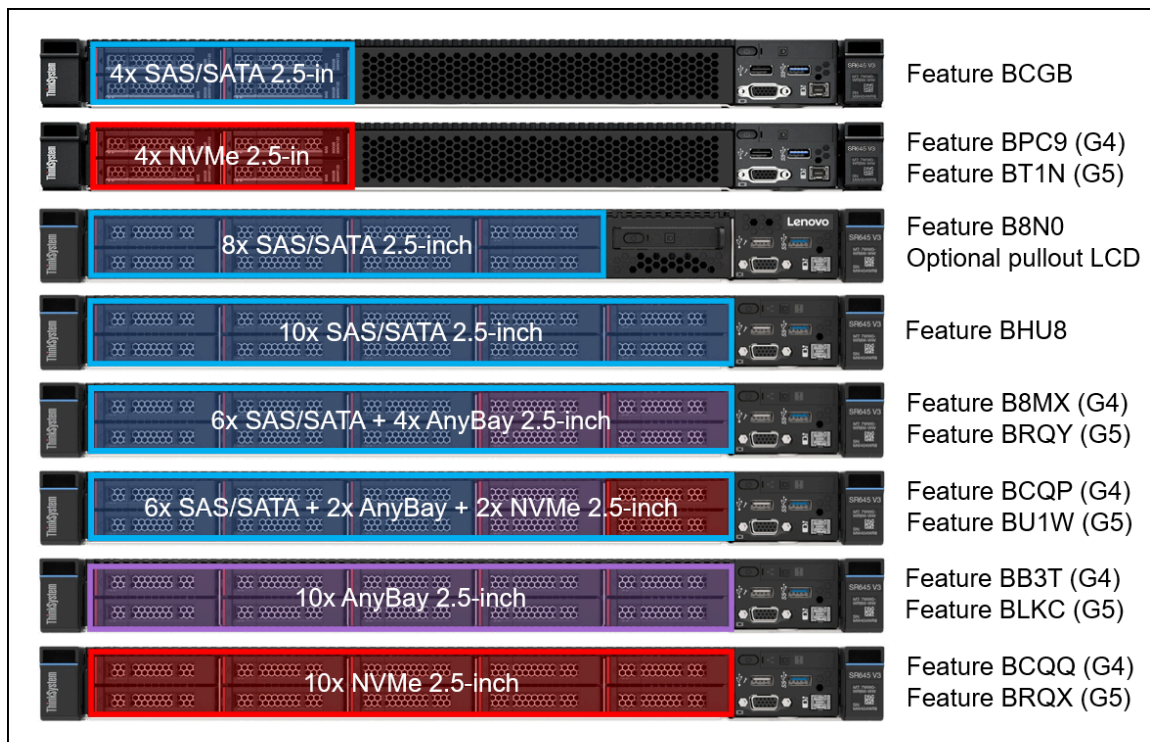

Figure 12. SR645 V3 front drive bay configurations - 2.5-inch drive bays without front PCIe slot support

The following figure shows the supported 2.5-inch drive bays drive bay configurations with front PCIe slot support. Front slots can be used with rear slots. See the [I/O expansion](#) for details.

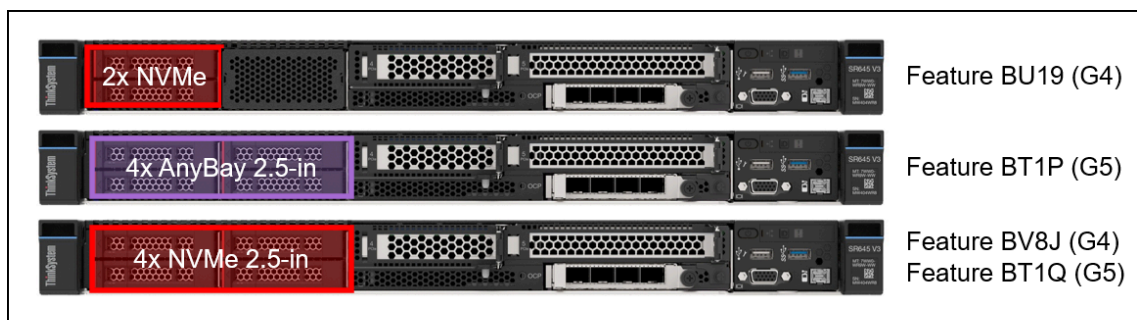

Figure 13. SR645 V3 front drive bay configurations - 2.5-inch drive bays with front PCIe slot support

The backplanes used to provide these drive bays are listed in the following table. The table includes a Top Choice Express column; for CTO orders, select a TCE component for faster delivery. See the [Top Choice](#) section for more information.

Field upgrades: Most front backplanes are available as part numbers for field upgrades using upgrade kits, as described in the [Field upgrades](#) section below.

Table 25. Backplanes for front drive bays

Feature code	Description	Top Choice Express	PCIe Gen	SAS Gen	Max qty
Front 3.5-inch drive backplanes					

Feature code	Description	Top Choice Express	PCIe Gen	SAS Gen	Max qty
B8L3	ThinkSystem 1U/2U 4x3.5" SAS/SATA Backplane	TCE	-	12Gb	1
BS7L	ThinkSystem V3 1U 3.5" 2x SATA+2x SATA/NVMe Backplane	Not TCE	Gen4	24Gb	1
B8N1	ThinkSystem 1U 4x3.5" AnyBay Backplane	Not TCE	Gen4	24Gb	1
Front EDSFF drive backplanes					
B981	ThinkSystem 1U 16xEDSFF Backplane	Not TCE	Gen4	-	1
Front 2.5-inch drive backplanes - 4 drive bays - no support for front PCIe slots					
BCGB	ThinkSystem 1U 4x2.5" SAS/SATA Backplane	Not TCE	-	12Gb	1
BPC9	ThinkSystem 1U 4x 2.5" NVMe Gen 4 Backplane	Not TCE	Gen4	-	1
BT1N	ThinkSystem V3 1U 4x2.5" Gen5 NVMe Backplane	Not TCE	Gen5	12Gb	1
Front 2.5-inch drive backplanes - 8 drive bays					
B8N0	ThinkSystem 1U 8x2.5" SAS/SATA Backplane	TCE	-	12Gb	1
Front 2.5-inch drive backplanes - 10 drive bays					
BRQY	ThinkSystem 1U 2.5" 6 SAS/SATA 4 AnyBay Gen5 Backplane	Not TCE	Gen5	24Gb	1
BU1W	ThinkSystem 1U 10x2.5" (6x SAS/SATA 2x AnyBay 2x NVMe) Gen5 Backplane	TCE	Gen5	24Gb	1
BB3T	ThinkSystem 1U 10x2.5" AnyBay Backplane	TCE	Gen4	24Gb	1
BLKC	ThinkSystem V3 1U 10x2.5" AnyBay Gen5 Backplane	TCE	Gen5	24Gb	1
BCQQ	ThinkSystem 1U 10x2.5" NVMe Backplane	Not TCE	Gen4	-	1
BRQX	ThinkSystem 1U 2.5" 10 NVMe Gen5 Backplane	TCE	Gen5	-	1
Front 2.5-inch drive backplanes - 2 drive bays - with front PCIe slot support					
BU19	ThinkSystem V3 2x2.5" BP NVMe with 1U 4x2.5" Chassis	Not TCE	Gen4	-	1
Front 2.5-inch drive backplanes - 4 drive bays - with front PCIe slot support					
BT1P	ThinkSystem V3 1U Front I/O 4x2.5" Gen5 AnyBay Backplane	Not TCE	Gen5	24Gb	1
BV8J	ThinkSystem V3 1U 4x2.5" Gen4 NVMe Backplane with 4x2.5" Chassis	Not TCE	Gen4	-	1
BT1Q	ThinkSystem V3 1U Front I/O 4x2.5" Gen5 NVMe Backplane	Not TCE	Gen5	-	1

Rear 2.5-inch and 7mm drive bays

The SR645 V3 supports hot-swap drives installed at the rear of the server chassis. Supported configurations are as follows:

- 2x 2.5-inch hot-swap SAS/SATA drive bays
- 2x 2.5-inch hot-swap NVMe drive bays (PCIe Gen 4)
- 2x 7mm SAS/SATA drive bays
- 2x 7mm NVMe drive bays (PCIe Gen 4)

The configurations are shown in the following figure.

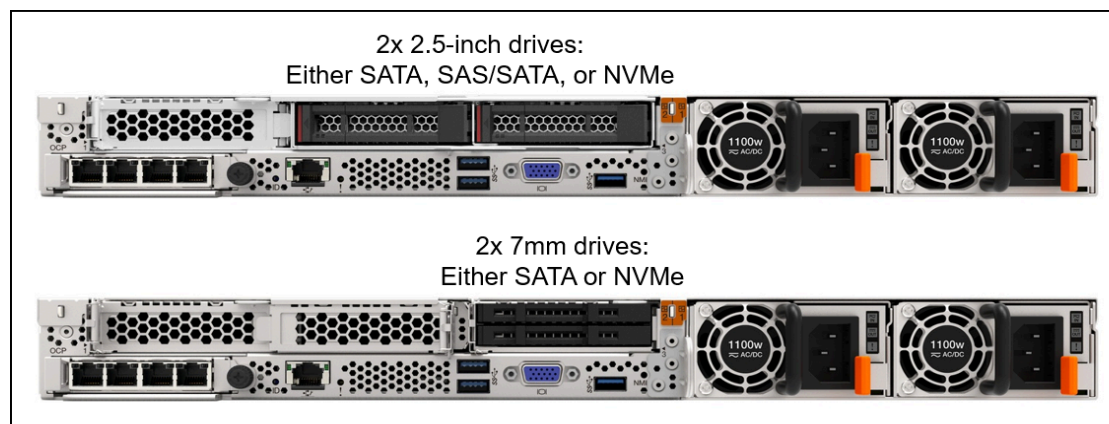

Figure 14. Rear drive bay configurations

The backplanes used to provide these drive bays in CTO orders are listed in the following table. Backplanes are also available as part numbers for field upgrades using upgrade kits, as described in the [Field upgrades](#) section below.

The SR645 V3 supports three different 7mm drive options installed in slot 3:

- 7mm drive backplane supporting SATA or NVMe drives, without integrated RAID. Optional RAID functionality is provided by a separate RAID adapter installed in a slot (feature BU0N)
- 7mm drive backplane supporting NVMe drives (no SATA support) with integrated RAID support via an onboard Marvell 88NR2241 NVMe RAID controller (feature B8Q2)
- 7mm drive backplane supporting SATA or NVMe drives with integrated RAID support via an onboard Broadcom RAID controller (feature BYFG)

Table 26. Backplanes for rear drive bays

Feature code	Description	Top Choice Express	Maximum supported
Rear - 2.5-inch drive backplanes			
BQZX	ThinkSystem 1U 2x2.5" SATA Rear Backplane	Not TCE	1
B8MY	ThinkSystem 1U 2x2.5" SAS/SATA Rear Backplane	Not TCE	1
BDY6	ThinkSystem 1U 2x2.5" NVMe Rear Backplane	Not TCE	1
Rear - 7mm drive backplane			
BU0N	ThinkSystem 7mm SATA/NVMe 2-Bay Rear Enablement Kit v2	Not TCE	1
B8Q2	ThinkSystem 1U 7mm Drive Kit w/ NVMe RAID (Marvell RAID)	Not TCE	1
BYFG	ThinkSystem 7mm SATA/NVMe 2-Bay Rear Hot-Swap RAID Enablement Kit (Broadcom RAID)	Not TCE	1

Feature code	Description	Top Choice Express	Maximum supported
Hardware RAID support for ThinkSystem 7mm SATA/NVMe 2-Bay Rear Enablement Kit v2 (BU0N) (optional)			
BT7P	ThinkSystem RAID 540-8i for M.2/7mm NVMe Boot Enablement	Not TCE	1

The use of rear 2.5-inch drive bays has the following configuration rules:

- With 2.5-inch rear drive bays, only slot 1 is available. Slot 2 and 3 are not available
- GPUs are not supported

The use of the 7mm rear drive bays has the following configuration rules:

- 7mm rear drive bays occupy slot 3; slots 1 and 2 are available and slot 2 is a low profile slot. Slot 3 is not available.
- GPUs are not supported
- For ThinkSystem 7mm SATA/NVMe 2-Bay Rear Enablement Kit v2 (feature BU0N):
 - The 7mm drive bays support either SATA drives or NVMe drives but not both. You specify SATA or NVMe in the configurator using feature codes BTTV (SATA) or BTTW (NVMe).
 - If RAID support is not required, the 7mm drives connect to an onboard port; No additional adapter is required
 - If RAID support is required, select feature code BS7A in the configurator to enable RAID
 - The support of RAID-1 with the 7mm drives requires an additional RAID adapter that is installed in PCIe slot 2:
 - RAID support for 7mm NVMe drives requires a RAID 540-8i adapter operating in Tri-Mode (feature BT7P)
 - The RAID adapter used for 7mm drive support cannot be configured for use with other drive bays (not even with M.2)
- For ThinkSystem 1U 7mm Drive Kit w/ NVMe RAID (feature B8Q2)
 - The adapter only supports NVMe drives
 - RAID functionality is integrated into the 7mm backplane using a Marvell 88NR2241 NVMe RAID Controller
- For ThinkSystem 7mm SATA/NVMe 2-Bay Rear Hot-Swap RAID Enablement Kit (feature BYFG)
 - The 7mm drive bays support either SATA drives or NVMe drives but not both.
 - RAID functionality is integrated into the 7mm backplane using a Broadcom RAID Controller
 - Supports RAID-0, RAID-1
- M.2 and 7mm are supported together in certain combinations, as listed in the table in the following section.

7mm and M.2 supported combinations

The following table lists the supported combinations of 7mm drives and M.2 drives.

Table 27. Supported combinations of M.2 and 7mm drives

Combination	M.2								7mm					
	M.2 x1 SATA	M.2 x1 NVMe	M.2 x4 NVMe	M.2 x4 SATA	M.2 NVMe RAID	M.2 x4 SATA with RAID 5350-8i	M.2 x4 NVMe with RAID 540-8i	M.2 SATA/ NVMe RAID	7mm SATA	7mm NVMe	7mm NVMe RAID	7mm SATA with RAID 5350-8i	7mm NVMe with RAID 540-8i	7mm SATA/ NVMe RAID
Feature	B5XJ	B5XJ	BM8X	BM8X	B8P9	BM8X+ BT7N	BM8X+ BT7P	BYFF	BU0N	BU0N	B8Q2	BU0N+ BT7N	BU0N+ BT7P	BYFG
M.2 x1 SATA + 7mm SATA	Y								Y					
M.2 x1 SATA + 7mm NVMe	Y									Y				
M.2 x1 SATA + 7mm SATA with RAID 5350-8i	Y											Y		
M.2 x1 SATA + 7mm NVMe with RAID 540-8i	Y												Y	
M.2 x1 NVMe + 7mm SATA		Y							Y					
M.2 x1 NVMe + 7mm NVMe		Y								Y				
M.2 x1 NVMe + 7mm SATA with RAID 5350-8i		Y										Y		
M.2 x1 NVMe + 7mm NVMe with RAID 540-8i		Y											Y	
M.2 x4 NVMe + 7mm SATA			Y						Y					
M.2 x4 NVMe + 7mm NVMe			Y							Y				
M.2 x4 NVMe + 7mm SATA with RAID 5350-8i			Y									Y		
M.2 x4 NVMe + 7mm NVMe with RAID 540-8i			Y										Y	
M.2 x4 SATA + 7mm NVMe				Y						Y				
M.2 x4 SATA + 7mm SATA with RAID 5350-8i				Y								Y		
M.2 x4 SATA + 7mm NVMe with RAID 540-8i				Y									Y	

	M.2					7mm									
Combination	M.2 x1 SATA	M.2 x1 NVMe	M.2 x4 NVMe	M.2 x4 SATA	M.2 NVMe RAID	M.2 x4 SATA with RAID 5350-8i	M.2 x4 NVMe with RAID 540-8i	M.2 SATA/ NVMe RAID	7mm SATA	7mm NVMe	7mm NVMe RAID	7mm SATA with RAID 5350-8i	7mm NVMe with RAID 540-8i	7mm SATA/ NVMe RAID	
Feature	B5XJ	B5XJ	BM8X	BM8X	B8P9	BM8X+ BT7N	BM8X+ BT7P	BYFF	BU0N	BU0N	B8Q2	BU0N+ BT7N	BU0N+ BT7P	BYFG	
M.2 x4 SATA with RAID 5350-8i + 7mm SATA						Y			Y						
M.2 x4 SATA with RAID 5350-8i + 7mm NVMe						Y				Y					
M.2 x4 NVMe with RAID 540-8i + 7mm SATA							Y		Y						
M.2 x4 NVMe with RAID 540-8i + 7mm NVMe							Y			Y					
M.2 SATA/ NVMe RAID + 7mm SATA								Y	Y						
M.2 SATA/ NVMe RAID + 7mm NVMe								Y		Y					
M.2 SATA/ NVMe RAID + 7mm NVMe RAID								Y			Y				
M.2 x1 SATA + 7mm SATA/ NVMe RAID	Y													Y	
M.2 x1 NVMe + 7mm SATA/ NVMe RAID		Y												Y	
M.2 x4 NVMe + 7mm SATA/ NVMe RAID			Y											Y	
M.2 x4 SATA + 7mm SATA/ NVMe RAID				Y										Y	
M.2 NVMe RAID + 7mm SATA/ NVMe RAID					Y									Y	
M.2 SATA/ NVMe RAID + 7mm SATA/ NVMe RAID								Y						Y	

Storage configurations

This section describes the various combinations of front and rear drives that the server supports, as well as M.2 support.

Tip: These tables are based on Config Matrix 3.5 in TRD 9.8

In this section:

- [Overview - 3.5-inch front bays](#)
- [Overview - 2.5-inch front bays without front slots](#)
- [Overview - 2.5-inch front bays with front slots](#)
- [Details - 3.5-inch drive bay chassis configurations](#)
- [Details - 2.5-inch drive bay chassis configurations without front slots](#)
- [Details - 2.5-inch drive bay chassis configurations with front slots](#)

The following tables summarize the storage configurations for the SR645 V3. For details, including processor requirements, M.2 and 7mm support, and controller selections, see the Details tables.

Overview - 3.5-inch front bays

The following table summarizes the configurations that use 3.5-inch front drive bays.

Click to jump down to the [details of the 3.5-inch configurations](#).

Return to [Storage configurations](#).

Table 28. Overview - 3.5-inch front bays

Config	Total drives (NVMe)	Front		Rear 2.5"		Front backplane	Rear backplane
		SAS/SATA	Any Bay	SAS/SATA	NVMe		
1	4 (0)	4	0	0	0	4x SAS/SATA (B8L3)	None
2A	6 (2)	4	0	0	2	4x SAS/SATA (B8L3)	2x NVMe (BDY6)
3	6 (0)	4	0	2	0	4x SAS/SATA (B8L3)	2x SATA (BQZX) (for OB SATA) or 2x SAS/SATA (B8MY)
6S	4 (4)	0	4	0	0	4x AnyBay G4 (B8N1)	None
6	4 (4)	0	4	0	0	4x AnyBay G4 (B8N1)	None
11	4 (2)	2	2	0	0	2x SATA, 2x SATA/NVMe (BS7L)	None
11A	4 (2)	2	2	0	0	2x SATA, 2x SATA/NVMe (BS7L)	None
30	4 (4)	0	4	0	0	4x AnyBay G4 (B8N1)	None

Overview - 2.5-inch front bays without front slots

The following table summarizes the configurations that use 2.5-inch front drive bays but do not support front PCIe slots.

Click to jump down to the [details of the 2.5-inch configurations](#).

Return to [Storage configurations](#).

Table 29. Overview - 2.5-inch front bays without front slots

Config	Total drives (NVMe)	Front				Rear 2.5"		Front backplane	Rear backplane
		SAS/SATA	Any Bay	NVMe	EDSFF	SAS/SATA	NVMe		
9H	10 (4)	6	4	0	0	0	0	6x SAS/SATA, 4x AnyBay G5 (BRQY)	None
9WH	10 (4)	6	4	0	0	0	0	6x SAS/SATA, 4x AnyBay G5 (BRQY)	None
9SH	10 (4)	6	4	0	0	0	0	6x SAS/SATA, 4x AnyBay G5 (BRQY)	None
10AH	12 (4)	6	4	0	0	2	0	6x SAS/SATA, 4x AnyBay G5 (BRQY)	2x SAS/SATA (B8MY)
12SH	10 (4)	6	2	2	0	0	0	6x SAS/SATA, 2x AnyBay, 2x NVMe G5 (BU1W)	None
12WH	10 (4)	6	2	2	0	0	0	6x SAS/SATA, 2x AnyBay, 2x NVMe G5 (BU1W)	None
12BH	10 (4)	6	2	2	0	0	0	6x SAS/SATA, 2x AnyBay, 2x NVMe G5 (BU1W)	None

Config	Total drives (NVMe)	Front				Rear 2.5"		Front backplane	Rear backplane
		SAS/SATA	Any Bay	NVMe	EDSFF	SAS/SATA	NVMe		
18	10 (10)	0	10	0	0	0	0	10x AnyBay G4 (BB3T)	None
18H	10 (10)	0	10	0	0	0	0	10x AnyBay G5 (BLKC)	None
21	8 (0)	8	0	0	0	0	0	8x SAS/SATA (B8N0)	None
21A	8 (0)	8	0	0	0	0	0	8x SAS/SATA (B8N0)	None
21W	8 (0)	8	0	0	0	0	0	8x SAS/SATA (B8N0)	None
21	8 (0)	8	0	0	0	0	0	8x SAS/SATA (B8N0)	None
25	16 (16)	0	0	0	16	0	0	16x EDSFF (B981)	None
26	4 (0)	4	0	0	0	0	0	4x SAS/SATA (BCGB)	None
26W	4 (0)	4	0	0	0	0	0	4x SAS/SATA (BCGB)	None
28	10 (10)	0	0	10	0	0	0	10x NVMe G4 (BCQQ)	None
28H	10 (10)	0	0	10	0	0	0	10x NVMe G5 (BRQX)	None
28A	12 (12)	0	0	10	0	0	2	10x NVMe G4 (BCQQ)	2x NVMe (BDY6)
28AH	12 (12)	0	0	10	0	0	2	10x NVMe G5 (BRQX)	2x NVMe (BDY6)
28W	10 (10)	0	0	10	0	0	0	10x NVMe G4 (BCQQ)	None
28WH	10 (10)	0	0	10	0	0	0	10x NVMe G5 (BRQX)	None
29	8 (8)	0	8	0	0	0	0	10x AnyBay G4 (BB3T)	None
29W	8 (8)	0	8	0	0	0	0	10x AnyBay G4 (BB3T)	None
29A	10 (10)	0	10	0	0	0	0	10x AnyBay G4 (BB3T)	None
29AW	10 (10)	0	10	0	0	0	0	10x AnyBay G4 (BB3T)	None
45	4 (4)	0	0	4	0	0	0	4x NVMe G5 (BT1N)	None
45W	4 (4)	0	0	4	0	0	0	4x NVMe G5 (BT1N)	None
46	4 (4)	0	0	4	0	0	0	4x NVMe G4 (BPC9)	None
46W	4 (4)	0	0	4	0	0	0	4x NVMe G4 (BPC9)	None
45S	4 (4)	0	0	4	0	0	0	4x NVMe G5 (BT1N)	None
46S	4 (4)	0	0	4	0	0	0	4x NVMe G4 (BPC9)	None

Overview - 2.5-inch front bays with front slots

The following table summarizes the configurations that use 2.5-inch front drive bays and support front PCIe slots.

Click to jump down to the [details of the 2.5-inch configurations](#).

Return to [Storage configurations](#).

Table 30. Overview - 2.5-inch front bays with front slots

Config	Total drives (NVMe)	Front				Rear 2.5"		Front backplane	Rear backplane
		SAS/SATA	Any Bay	NVMe	EDSFF	SAS/SATA	NVMe		
31	4 (4)	0	4	0	0	0	0	4x AnyBay G4 (BT1P)	None
32	6 (6)	0	4	0	0	0	2	4x AnyBay G4 (BT1P)	2x NVMe (BDY6)
33	6 (4)	0	4	0	0	2	0	4x AnyBay G4 (BT1P)	2x SAS/SATA (B8MY)
35	4 (4)	0	4	0	0	0	0	4x AnyBay G4 (BT1P)	None
36	6 (6)	0	4	0	0	0	2	4x AnyBay G4 (BT1P)	2x NVMe (BDY6)
37	6 (4)	0	4	0	0	2	0	4x AnyBay G4 (BT1P)	2x SAS/SATA (B8MY)
39	4 (4)	0	0	4	0	0	0	4x NVMe G4 (BT1Q)	None
39	6 (6)	0	0	4	0	0	2	4x NVMe G4 (BT1Q)	2x NVMe (BDY6)
40	4 (4)	0	0	4	0	0	0	4x NVMe G4 (BT1Q)	None
40	6 (6)	0	0	4	0	0	2	4x NVMe G4 (BT1Q)	2x NVMe (BDY6)

Config	Total drives (NVMe)	Front				Rear 2.5"		Front backplane	Rear backplane
		SAS/SATA	Any Bay	NVMe	EDSFF	SAS/SATA	NVMe		
41	2 (2)	0	0	2	0	0	0	2x NVMe G4 (BU19)	None
41	4 (4)	0	0	2	0	0	2	2x NVMe G4 (BU19)	2x NVMe (BDY6)
44	4 (4)	0	0	4	0	0	0	4x NVMe G4 (BV8J)	None
44	6 (6)	0	0	4	0	0	2	4x NVMe G4 (BV8J)	2x NVMe (BDY6)

Details - 3.5-inch front bays

The following table lists the detailed configurations that use 3.5-inch front drive bays.

Click to go back to the [overview of 3.5-inch configurations](#).

Return to [Storage configurations](#).

In the table:

- **M.2 x4 SATA/NVMe Non-RAID** means the M.2 SATA/x4 NVMe adapter (4Y37A79663) with either SATA or NVMe drives. RAID is not supported.
- **M.2 x4 SATA/NVMe with SFF RAID** means the M.2 SATA/x4 NVMe adapter (4Y37A79663) with either SATA or NVMe drives. RAID is supported with the addition of the RAID 5350-8i adapter (SATA drives only) or RAID 540-8i adapter (NVMe drives only) in a rear slot.
- **M.2 x1 SATA Non-RAID** means the M.2 SATA/x1 NVMe adapter (4Y37A09738) with SATA drives. NVMe drives not supported. RAID is not supported.
- **M.2 x1 NVMe Non-RAID** means the M.2 SATA/x1 NVMe adapter (4Y37A09738) with NVMe drives. SATA drives not supported. RAID is not supported.
- **M.2 NVMe RAID** means the M.2 RAID NVMe adapter (B8P9) with NVMe drives. SATA drives not supported. RAID-0 and RAID-1 are supported with the integrated Marvell RAID controller.
- **M.2 SATA/NVMe RAID** means the M.2 RAID SATA/NVMe adapter (BYFF) with SATA or NVMe drives. RAID-0 and RAID-1 are supported with the integrated Broadcom RAID controller.
- **7mm SATA Non-RAID** means the 7mm SATA/NVMe kit (BU0N) with SATA drives. RAID is not supported.
- **7mm NVMe Non-RAID** means the 7mm SATA/NVMe kit (BU0N) with NVMe drives. RAID is not supported.
- **7mm NVMe RAID** means the 7mm NVMe RAID kit (B8Q2) with NVMe drives. SATA drives not supported. RAID-0 and RAID-1 are supported with the integrated Marvell RAID controller.
- **7mm SATA/NVMe RAID** means the 7mm SATA/NVMe RAID kit (BYFG) with SATA or NVMe drives. RAID-0 and RAID-1 are supported with the integrated Broadcom RAID controller.
- **7mm SATA with SFF RAID 5350-8i** means the 7mm SATA/NVMe kit (BU0N) with SATA drives. NVMe drives not supported. RAID is supported with the addition of the RAID 5350-8i adapter in a rear slot.
- **7mm NVMe with SFF RAID 540-8i** means the 7mm SATA/NVMe kit (BU0N) with NVMe drives. SATA drives not supported. RAID is supported with the addition of the RAID 540-8i adapter in a rear slot.

Table 31. Details - 3.5-inch front bays

Config	CPUs	Front 3.5"		Rear 2.5"		Front backplane	Rear backplane	M.2						7mm				Supported controllers					
		SAS/SATA	AnyBay	SAS/SATA	NVMe			M.2 x4 SATA/NVMe Non-RAID	M.2 x4 SATA/NVMe with SFF RAID	M.2 x1 SATA Non-RAID	M.2 x1 NVMe Non-RAID	M.2 NVMe RAID	M.2 SATA/NVMe RAID	7mm SATA Non-RAID	7mm NVMe Non-RAID	7mm NVMe RAID	7mm SATA/NVMe RAID		7mm SATA with SFF RAID 5350-8i	7mm NVMe with SFF RAID 540-8i			
1-1	1 or 2	4	0	0	0	4x SAS/SATA (B8L3)	None	N	N	Y	Y	Y	Y	Y	Y	Y	Y	Y	Y	Y	Y	OB SATA	
1-2	1 or 2							N	N	Y	Y	Y	Y	Y	Y	Y	Y	Y	Y	Y	Y	Y	5350-8i
1-3	1 or 2							N	N	Y	Y	Y	Y	Y	Y	Y	Y	Y	Y	Y	Y	Y	4350-8i
1-4	1 or 2							N	N	Y	Y	Y	Y	Y	Y	Y	Y	Y	Y	Y	Y	Y	540-8i
1-5	1 or 2							N	N	Y	Y	Y	Y	Y	Y	Y	Y	Y	Y	Y	Y	Y	440-8i
1-2A	2							N	N	Y	Y	Y	Y	Y	Y	Y	Y	Y	Y	Y	Y	Y	9350-8i
1-4A	2							N	N	Y	Y	Y	Y	Y	Y	Y	Y	Y	Y	Y	Y	Y	940-8i
2A-2	2	4	0	0	2	4x SAS/SATA (B8L3)	2x NVMe (BDY6)	N	N	Y	Y	Y	Y	N	N	N	N	N	N	N	N	5350-8i + OB NVMe	
2A-3	2				N			N	Y	Y	Y	Y	N	N	N	N	N	N	N	N	N	4350-8i + OB NVMe	
2A-4	2				N			N	Y	Y	Y	Y	N	N	N	N	N	N	N	N	N	540-8i + OB NVMe	
2A-5	2				N			N	Y	Y	Y	Y	N	N	N	N	N	N	N	N	N	440-8i + OB NVMe	
3-1	1 or 2	4	0	2	0	4x SAS/SATA (B8L3)	2x SATA (BQZX) (for OB SATA) or 2x SAS/SATA (B8MY)	N	N	Y	Y	Y	Y	N	N	N	N	N	N	N	N	OB SATA	
3-2	1 or 2				N			N	Y	Y	Y	Y	N	N	N	N	N	N	N	N	N	5350-8i	
3-3	1 or 2				N			N	Y	Y	Y	Y	N	N	N	N	N	N	N	N	N	4350-8i	
3-4	1 or 2				N			N	Y	Y	Y	Y	N	N	N	N	N	N	N	N	N	540-8i	
3-5	1 or 2				N			N	Y	Y	Y	Y	N	N	N	N	N	N	N	N	N	440-8i	
6S-2	1	0	4	0	0	4x AnyBay G4 (B8N1)	None	N	N	N	Y	Y	Y	N	Y	Y	Y	Y	Y	Y	Y	5350-8i + OB NVMe	
6S-3	1				N			N	N	Y	Y	Y	N	Y	Y	Y	Y	Y	Y	Y	Y	4350-8i + OB NVMe	
6S-4	1				N			N	N	Y	Y	Y	N	Y	Y	Y	Y	Y	Y	Y	Y	540-8i + OB NVMe	
6S-5	1				N			N	N	Y	Y	Y	N	Y	Y	Y	Y	Y	Y	Y	Y	Y	440-8i + OB NVMe

Config	CPUs	Front 3.5"		Rear 2.5"		Front backplane	Rear backplane	M.2						7mm				Supported controllers	
		SAS/SATA	AnyBay	SAS/SATA	NVMe			M.2 x4 SATA/NVMe Non-RAID	M.2 x4 SATA/NVMe with SFF RAID	M.2 x1 SATA Non-RAID	M.2 x1 NVMe Non-RAID	M.2 NVMe RAID	M.2 SATA/NVMe RAID	7mm SATA Non-RAID	7mm NVMe Non-RAID	7mm NVMe RAID	7mm SATA/NVMe RAID		7mm SATA with SFF RAID 5350-8i
6-2	2	0	4	0	0	4x AnyBay G4 (B8N1)	None	N	N	Y	Y	Y	Y	Y	Y	Y	Y	Y	(5350-8i or 9350-8i) + OB NVMe
6-3	2							N	N	Y	Y	Y	Y	Y	Y	Y	Y	Y	4350-8i + OB NVMe
6-4	2							N	N	Y	Y	Y	Y	Y	Y	Y	Y	Y	(940-8i or 540-8i) + OB NVMe
6-5	2							N	N	Y	Y	Y	Y	Y	Y	Y	Y	Y	440-8i + OB NVMe
6-6	2							N	N	Y	Y	Y	Y	Y	Y	Y	Y	Y	9350-16i + OB NVMe
6-7	2							N	N	Y	Y	Y	Y	Y	Y	Y	Y	Y	(940-16i or 540-16i) + OB NVMe
11-1	2	2	2	0	0	2x SATA, 2x SATA/NVMe (BS7L)	None	N	N	Y	Y	Y	Y	Y	Y	Y	Y	Y	OB SATA + OB NVMe
11A-1	2	2	2	0	0	2x SATA, 2x SATA/NVMe (BS7L)	None	N	N	Y	Y	Y	Y	Y	Y	Y	Y	Y	OB SATA + OB NVMe
30-1	1 or 2	0	4	0	0	4x AnyBay G4 (B8N1)	None	N	N	Y	Y	Y	Y	Y	Y	Y	Y	Y	940-8i Tri-mode

Details - 2.5-inch front bays without front slots

The following table lists the detailed configurations that use 2.5-inch front drive bays without front PCIe slots.

Click to go back to the [overview of 2.5-inch configurations](#).

Return to [Storage configurations](#).

Table 32. Details - 2.5-inch front bays without front slots

Config	CPUs	Front 2.5"				Rear 2.5"		Front backplane	Rear backplane	M.2						7mm				Supported controllers				
		SAS/SATA	AnyBay	NVMe	EDSFF	SAS/SATA	NVMe			M.2 x4 SATA/NVMe Non-RAID	M.2 x4 SATA/NVMe with SFF RAID	M.2 x1 SATA Non-RAID	M.2 x1 NVMe Non-RAID	M.2 NVMe RAID	M.2 SATA/NVMe RAID	7mm SATA Non-RAID	7mm NVMe Non-RAID	7mm NVMe RAID	7mm SATA/NVMe RAID		7mm SATA with SFF RAID 5350-8i	7mm NVMe with SFF RAID 540-8i		
9H-1	2	6	4	0	0	0	0	6x SAS/SATA, 4x AnyBay G5 (BRQY)	None	Y	Y	Y	Y	Y	Y	Y	Y	Y	Y	Y	Y	Y	Y	9350-16i + OB NVMe
9H-2	2									Y	Y	Y	Y	Y	Y	Y	Y	Y	Y	Y	Y	Y	Y	4350-16i + OB NVMe
9H-3	2									Y	Y	Y	Y	Y	Y	Y	Y	Y	Y	Y	Y	Y	Y	(940-16i or 540-16i) + OB NVMe
9H-4	2									Y	Y	Y	Y	Y	Y	Y	Y	Y	Y	Y	Y	Y	Y	440-16i + OB NVMe
9H-5	2									Y	Y	Y	Y	Y	Y	Y	Y	Y	Y	Y	Y	Y	Y	9350-16i CFF + OB NVMe
9H-6	2									Y	Y	Y	Y	Y	Y	Y	Y	Y	Y	Y	Y	Y	Y	940-16i CFF + OB NVMe
9H-7	2									Y	Y	Y	Y	Y	Y	Y	Y	Y	Y	Y	Y	Y	Y	440-16i CFF + OB NVMe
9WH-1	2	6	4	0	0	0	0	6x SAS/SATA, 4x AnyBay G5 (BRQY)	None	N	N	N	N	N	N	N	Y	Y	Y	Y	Y	Y	9350-16i + OB NVMe	
9WH-2	2									N	N	N	N	N	N	N	Y	Y	Y	Y	Y	Y	Y	4350-16i + OB NVMe
9WH-3	2									N	N	N	N	N	N	N	Y	Y	Y	Y	Y	Y	Y	(940-16i or 540-16i) + OB NVMe
9WH-4	2									N	N	N	N	N	N	N	Y	Y	Y	Y	Y	Y	Y	440-16i + OB NVMe
9SH-1	1	6	4	0	0	0	0	6x SAS/SATA, 4x AnyBay G5 (BRQY)	None	N	Y	N	Y	Y	Y	N	Y	Y	Y	Y	Y	Y	Y	9350-16i + OB NVMe
9SH-2	1									N	Y	N	Y	Y	Y	N	Y	Y	Y	Y	Y	Y	Y	4350-16i + OB NVMe
9SH-3	1									N	Y	N	Y	Y	Y	N	Y	Y	Y	Y	Y	Y	Y	(940-16i or 540-16i) + OB NVMe
9SH-4	1									N	Y	N	Y	Y	Y	N	Y	Y	Y	Y	Y	Y	Y	440-16i + OB NVMe
10AH-5	2	6	4	0	0	2	0	6x SAS/SATA, 4x AnyBay G5 (BRQY)	2x SAS/SATA (B8MY)	Y	Y	Y	Y	Y	Y	N	N	N	N	N	N	N	N	9350-16i CFF + OB NVMe
10AH-6	2									Y	Y	Y	Y	Y	Y	N	N	N	N	N	N	N	N	940-16i CFF + OB NVMe
10AH-7	2									Y	Y	Y	Y	Y	Y	N	N	N	N	N	N	N	N	440-16i CFF + OB NVMe

Config	CPUs	Front 2.5"				Rear 2.5"		Front backplane	Rear backplane	M.2						7mm						Supported controllers	
		SAS/SATA	AnyBay	NVMe	EDSFF	SAS/SATA	NVMe			M.2 x4 SATA/NVMe Non-RAID	M.2 x4 SATA/NVMe with SFF RAID	M.2 x1 SATA Non-RAID	M.2 x1 NVMe Non-RAID	M.2 NVMe RAID	M.2 SATA/NVMe RAID	7mm SATA Non-RAID	7mm NVMe Non-RAID	7mm NVMe RAID	7mm SATA/NVMe RAID	7mm SATA with SFF RAID 5350-8i	7mm NVMe with SFF RAID 540-8i		
12SH-1	1	6	2	2	0	0	0	6x SAS/SATA, 2x AnyBay, 2x NVMe G5 (BU1W)	None	N	Y	N	Y	Y	Y	N	Y	Y	Y	Y	Y	Y	(5350-8i or 9350-8i) + OB NVMe
12SH-2	1									N	Y	N	Y	Y	Y	N	Y	Y	Y	Y	Y	Y	4350-8i + OB NVMe
12SH-3	1									N	Y	N	Y	Y	Y	N	Y	Y	Y	Y	Y	Y	(940-8i or 540-8i) + OB NVMe
12SH-4	1									N	Y	N	Y	Y	Y	N	Y	Y	Y	Y	Y	Y	440-8i + OB NVMe
12WH-1	2	6	2	2	0	0	0	6x SAS/SATA, 2x AnyBay, 2x NVMe G5 (BU1W)	None	N	N	N	N	N	N	N	Y	Y	Y	Y	Y	Y	(5350-8i or 9350-8i) + OB NVMe
12WH-2	2									N	N	N	N	N	N	N	Y	Y	Y	Y	Y	Y	4350-8i + OB NVMe
12WH-3	2									N	N	N	N	N	N	N	Y	Y	Y	Y	Y	Y	(940-8i or 540-8i) + OB NVMe
12WH-4	2									N	N	N	N	N	N	N	Y	Y	Y	Y	Y	Y	440-8i + OB NVMe
12BH-2	2	6	2	2	0	0	0	6x SAS/SATA, 2x AnyBay, 2x NVMe G5 (BU1W)	None	Y	Y	Y	Y	Y	Y	Y	Y	Y	Y	Y	Y	Y	(5350-8i or 9350-8i) + OB NVMe
12BH-3	2									Y	Y	Y	Y	Y	Y	Y	Y	Y	Y	Y	Y	Y	4350-8i + OB NVMe
12BH-4	2									Y	Y	Y	Y	Y	Y	Y	Y	Y	Y	Y	Y	Y	(940-8i or 540-8i) + OB NVMe
12BH-5	2									Y	Y	Y	Y	Y	Y	Y	Y	Y	Y	Y	Y	Y	440-8i + OB NVMe
12BH-6	2									Y	Y	Y	Y	Y	Y	Y	Y	Y	Y	Y	Y	Y	(5350-8i CFF or 9350-8i CFF) + OB NVMe
18-1	2	0	10	0	0	0	0	10x AnyBay G4 (BB3T)	None	Y	Y	Y	Y	Y	Y	Y	Y	Y	Y	Y	Y	Y	9350-16i + OB NVMe
18-2	2									Y	Y	Y	Y	Y	Y	Y	Y	Y	Y	Y	Y	Y	4350-16i + OB NVMe
18-3	2									Y	Y	Y	Y	Y	Y	Y	Y	Y	Y	Y	Y	Y	(940-16i or 540-16i) + OB NVMe
18-4	2									Y	Y	Y	Y	Y	Y	Y	Y	Y	Y	Y	Y	Y	440-16i + OB NVMe

Config	CPUs	Front 2.5"				Rear 2.5"		Front backplane	Rear backplane	M.2						7mm				Supported controllers					
		SAS/SATA	AnyBay	NVMe	EDSFF	SAS/SATA	NVMe			M.2 x4 SATA/NVMe Non-RAID	M.2 x4 SATA/NVMe with SFF RAID	M.2 x1 SATA Non-RAID	M.2 x1 NVMe Non-RAID	M.2 NVMe RAID	M.2 SATA/NVMe RAID	7mm SATA Non-RAID	7mm NVMe Non-RAID	7mm NVMe RAID	7mm SATA/NVMe RAID		7mm SATA with SFF RAID 5350-8i	7mm NVMe with SFF RAID 540-8i			
18H-1	2	0	10	0	0	0	0	10x AnyBay G5 (BLKC)	None	Y	Y	Y	Y	Y	Y	Y	Y	Y	Y	Y	Y	Y	Y	Y	9350-16i + OB NVMe
18H-2	2									Y	Y	Y	Y	Y	Y	Y	Y	Y	Y	Y	Y	Y	Y	Y	4350-16i + OB NVMe
18H-3	2									Y	Y	Y	Y	Y	Y	Y	Y	Y	Y	Y	Y	Y	Y	Y	(940-16i or 540-16i) + OB NVMe
18H-4	2									Y	Y	Y	Y	Y	Y	Y	Y	Y	Y	Y	Y	Y	Y	Y	440-16i + OB NVMe
21-1	1 or 2	8	0	0	0	0	0	8x SAS/SATA (B8N0)	None	Y	Y	Y	Y	Y	Y	Y	Y	Y	Y	Y	Y	Y	Y	Y	OB SATA
21-2	1 or 2									Y	Y	Y	Y	Y	Y	Y	Y	Y	Y	Y	Y	Y	Y	Y	(5350-8i or 9350-8i)
21-3	1 or 2									Y	Y	Y	Y	Y	Y	Y	Y	Y	Y	Y	Y	Y	Y	Y	4350-8i
21-4	1 or 2									Y	Y	Y	Y	Y	Y	Y	Y	Y	Y	Y	Y	Y	Y	Y	(940-8i or 540-8i)
21-5	1 or 2									Y	Y	Y	Y	Y	Y	Y	Y	Y	Y	Y	Y	Y	Y	Y	440-8i
21-6	1 or 2									Y	Y	Y	Y	Y	Y	Y	Y	Y	Y	Y	Y	Y	Y	Y	9350-16i
21-7	1 or 2									Y	Y	Y	Y	Y	Y	Y	Y	Y	Y	Y	Y	Y	Y	Y	(940-16i or 540-16i)
21-8	2									Y	Y	Y	Y	Y	Y	Y	Y	Y	Y	Y	Y	Y	Y	Y	9350-16i CFF
21-9	2									Y	Y	Y	Y	Y	Y	Y	Y	Y	Y	Y	Y	Y	Y	Y	940-16i CFF
21-10	2									Y	Y	Y	Y	Y	Y	Y	Y	Y	Y	Y	Y	Y	Y	Y	440-16i CFF
21-11	2									Y	Y	Y	Y	Y	Y	Y	Y	Y	Y	Y	Y	Y	Y	Y	(5350-8i CFF or 9350-8i CFF or 545-8i CFF)
21A-1	1	8	0	0	0	0	0	8x SAS/SATA (B8N0)	None	Y	Y	Y	Y	Y	Y	Y	Y	Y	Y	Y	Y	Y	Y	Y	9350-16i CFF
21A-2	1									Y	Y	Y	Y	Y	Y	Y	Y	Y	Y	Y	Y	Y	Y	Y	940-16i CFF
21A-3	1									Y	Y	Y	Y	Y	Y	Y	Y	Y	Y	Y	Y	Y	Y	Y	440-16i CFF
21A-4	1									Y	Y	Y	Y	Y	Y	Y	Y	Y	Y	Y	Y	Y	Y	Y	(5350-8i CFF or 9350-8i CFF or 545-8i CFF)
21W-1	2	8	0	0	0	0	0	8x SAS/SATA (B8N0)	None	N	N	N	N	N	N	N	Y	Y	Y	Y	Y	Y	Y	Y	OB SATA
21W-2	2									N	N	N	N	N	N	N	Y	Y	Y	Y	Y	Y	Y	Y	(5350-8i or 9350-8i)
21W-3	2									N	N	N	N	N	N	N	Y	Y	Y	Y	Y	Y	Y	Y	4350-8i
21W-4	2									N	N	N	N	N	N	N	Y	Y	Y	Y	Y	Y	Y	Y	(940-8i or 540-8i)
21W-5	2									N	N	N	N	N	N	N	Y	Y	Y	Y	Y	Y	Y	Y	440-8i
21W-6	2									N	N	N	N	N	N	N	Y	Y	Y	Y	Y	Y	Y	Y	9350-16i
21-7	2	8	0	0	0	0	0	8x SAS/SATA (B8N0)	None	N	N	N	N	N	N	N	Y	Y	Y	Y	Y	Y	Y	Y	(940-16i or 540-16i)

Config	CPUs	Front 2.5"				Rear 2.5"		Front backplane	Rear backplane	M.2						7mm				Supported controllers								
		SAS/SATA	AnyBay	NVMe	EDSFF	SAS/SATA	NVMe			M.2 x4 SATA/NVMe Non-RAID	M.2 x4 SATA/NVMe with SFF RAID	M.2 x1 SATA Non-RAID	M.2 x1 NVMe Non-RAID	M.2 NVMe RAID	M.2 SATA/NVMe RAID	7mm SATA Non-RAID	7mm NVMe Non-RAID	7mm NVMe RAID	7mm SATA/NVMe RAID		7mm SATA with SFF RAID 5350-8i	7mm NVMe with SFF RAID 540-8i						
25-1	2	0	0	0	16	0	0	16x EDSFF (B981)	None	N	N	N	Y	Y	Y	N	Y	Y	Y	Y	Y	Y	Retimer					
26-1	1 or 2	4	0	0	0	0	0	4x SAS/SATA (BCGB)	None	N	Y	Y	Y	Y	Y	Y	Y	Y	Y	Y	Y	OB SATA						
26-2	1 or 2									N	Y	Y	Y	Y	Y	Y	Y	Y	Y	Y	Y	Y	Y	Y	Y	Y	(5350-8i or 9350-8i)	
26-3	1 or 2									N	Y	Y	Y	Y	Y	Y	Y	Y	Y	Y	Y	Y	Y	Y	Y	Y	Y	4350-8i
26-4	1 or 2									N	Y	Y	Y	Y	Y	Y	Y	Y	Y	Y	Y	Y	Y	Y	Y	Y	Y	(940-8i or 540-8i)
26-5	1 or 2									N	Y	Y	Y	Y	Y	Y	Y	Y	Y	Y	Y	Y	Y	Y	Y	Y	Y	440-8i
26W-1	2	4	0	0	0	0	0	4x SAS/SATA (BCGB)	None	N	N	N	N	N	N	N	Y	Y	Y	Y	Y	OB SATA						
26W-2	2									N	N	N	N	N	N	N	N	N	Y	Y	Y	Y	Y	Y	Y	Y	(5350-8i or 9350-8i)	
26W-3	2									N	N	N	N	N	N	N	N	N	Y	Y	Y	Y	Y	Y	Y	Y	4350-8i	
26W-4	2									N	N	N	N	N	N	N	N	N	Y	Y	Y	Y	Y	Y	Y	Y	(940-8i or 540-8i)	
26W-5	2									N	N	N	N	N	N	N	N	N	Y	Y	Y	Y	Y	Y	Y	Y	Y	440-8i
28-1	2	0	0	10	0	0	0	10x NVMe G4 (BCQQ)	None	Y	Y	Y	Y	Y	Y	Y	Y	Y	Y	Y	Y	OB NVMe						
28H-1	2	0	0	10	0	0	0	10x NVMe G5 (BRQX)	None	Y	Y	Y	Y	Y	Y	Y	Y	Y	Y	Y	Y	OB NVMe						
28A-1	2	0	0	10	0	0	2	10x NVMe G4 (BCQQ)	2x NVMe (BDY6)	Y	Y	Y	Y	Y	Y	N	N	N	N	N	N	OB NVMe						
28AH-1	2	0	0	10	0	0	2	10x NVMe G5 (BRQX)	2x NVMe (BDY6)	Y	Y	Y	Y	Y	Y	N	N	N	N	N	N	OB NVMe						
28W-1	2	0	0	10	0	0	0	10x NVMe G4 (BCQQ)	None	N	N	N	N	N	N	Y	Y	Y	Y	Y	Y	OB NVMe						
28WH-1	2	0	0	10	0	0	0	10x NVMe G5 (BRQX)	None	N	N	N	N	N	N	Y	Y	Y	Y	Y	Y	OB NVMe						
29-1	1 or 2	0	8	0	0	0	0	10x AnyBay G4 (BB3T)	None	N	Y	Y	Y	Y	Y	Y	Y	Y	Y	Y	Y	940-8i Tri-mode						
29-2	1 or 2									N	Y	Y	Y	Y	Y	Y	Y	Y	Y	Y	Y	Y	Y	Y	Y	Y	Y	9450-8i Tri-mode
29W-1	2	0	8	0	0	0	0	10x AnyBay G4 (BB3T)	None	N	N	N	N	N	N	Y	Y	Y	Y	Y	Y	940-8i Tri-mode						
29A-1	1 or 2	0	10	0	0	0	0	10x AnyBay G4 (BB3T)	None	N	Y	Y	Y	Y	Y	Y	Y	Y	Y	Y	Y	940-16i Tri-mode						
29A-3	1 or 2									N	Y	Y	Y	Y	Y	Y	Y	Y	Y	Y	Y	Y	Y	Y	Y	Y	Y	9450-16i Tri-mode
29AW-1	2	0	10	0	0	0	0	10x AnyBay G4 (BB3T)	None	N	N	N	N	N	N	Y	Y	Y	Y	Y	Y	940-16i Tri-mode						
45-1	2	0	0	4	0	0	0	4x NVMe G5 (BT1N)	None	N	Y	Y	Y	Y	Y	Y	Y	Y	Y	Y	Y	OB NVMe						

Config	CPUs	Front 2.5"				Rear 2.5"		Front backplane	Rear backplane	M.2						7mm				Supported controllers			
		SAS/SATA	AnyBay	NVMe	EDSFF	SAS/SATA	NVMe			M.2 x4 SATA/NVMe Non-RAID	M.2 x4 SATA/NVMe with SFF RAID	M.2 x1 SATA Non-RAID	M.2 x1 NVMe Non-RAID	M.2 NVMe RAID	M.2 SATA/NVMe RAID	7mm SATA Non-RAID	7mm NVMe Non-RAID	7mm NVMe RAID	7mm SATA/NVMe RAID		7mm SATA with SFF RAID 5350-8i	7mm NVMe with SFF RAID 540-8i	
45W-1	2	0	0	4	0	0	0	4x NVMe G5 (BT1N)	None	N	N	N	N	N	N	N	Y	Y	Y	Y	Y	Y	OB NVMe
46-1	2	0	0	4	0	0	0	4x NVMe G4 (BPC9)	None	N	Y	Y	Y	Y	Y	Y	Y	Y	Y	Y	Y	Y	OB NVMe
46W-1	2	0	0	4	0	0	0	4x NVMe G4 (BPC9)	None	N	N	N	N	N	N	N	Y	Y	Y	Y	Y	Y	OB NVMe
45S-1	1	0	0	4	0	0	0	4x NVMe G5 (BT1N)	None	N	Y	N	Y	Y	Y	N	Y	Y	Y	Y	Y	Y	OB NVMe
46S-1	1	0	0	4	0	0	0	4x NVMe G4 (BPC9)	None	N	Y	N	Y	Y	Y	N	Y	Y	Y	Y	Y	Y	OB NVMe

Details - 2.5-inch front bays with front slots

The following table lists the detailed configurations that use 2.5-inch front drive bays without front PCIe slots.

Click to go back to the [overview of 2.5-inch configurations](#).

Return to [Storage configurations](#).

Table 33. Details - 2.5-inch front bays with front slots

Config	CPUs	Front 2.5"				Rear 2.5"		Front backplane	Rear backplane	M.2						7mm				Supported controllers			
		SAS/SATA	AnyBay	NVMe	EDSFF	SAS/SATA	NVMe			M.2 x4 SATA/NVMe Non-RAID	M.2 x4 SATA/NVMe with SFF RAID	M.2 x1 SATA Non-RAID	M.2 x1 NVMe Non-RAID	M.2 NVMe RAID	M.2 SATA/NVMe RAID	7mm SATA Non-RAID	7mm NVMe Non-RAID	7mm NVMe RAID	7mm SATA/NVMe RAID		7mm SATA with SFF RAID 5350-8i	7mm NVMe with SFF RAID 540-8i	
31-1	2	0	4	0	0	0	0	4x AnyBay G4 (BT1P)	None	N	N	N	N	N	N	N	Y	Y	Y	Y	Y	Y	(5350-8i or 9350-8i) + OB NVMe
31-2	2									N	N	N	N	N	N	N	Y	Y	Y	Y	Y	Y	4350-8i + OB NVMe
31-3	2									N	N	N	N	N	N	N	Y	Y	Y	Y	Y	Y	(940-8i or 540-8i) + OB NVMe
31-4	2									N	N	N	N	N	N	N	Y	Y	Y	Y	Y	Y	440-8i + OB NVMe

Config	CPUs	Front 2.5"				Rear 2.5"		Front backplane	Rear backplane	M.2						7mm				Supported controllers				
		SAS/SATA	AnyBay	NVMe	EDSFF	SAS/SATA	NVMe			M.2 x4 SATA/NVMe Non-RAID	M.2 x4 SATA/NVMe with SFF RAID	M.2 x1 SATA Non-RAID	M.2 x1 NVMe Non-RAID	M.2 NVMe RAID	M.2 SATA/NVMe RAID	7mm SATA Non-RAID	7mm NVMe Non-RAID	7mm NVMe RAID	7mm SATA/NVMe RAID		7mm SATA with SFF RAID 5350-8i	7mm NVMe with SFF RAID 540-8i		
32-1	2	0	4	0	0	0	2	4x AnyBay G4 (BT1P)	2x NVMe (BDY6)	N	N	N	N	N	N	N	N	N	N	N	N	N	N	(5350-8i or 9350-8i) + OB NVMe
32-2	2									N	N	N	N	N	N	N	N	N	N	N	N	N	N	4350-8i + OB NVMe
32-3	2									N	N	N	N	N	N	N	N	N	N	N	N	N	N	(940-8i or 540-8i) + OB NVMe
32-4	2									N	N	N	N	N	N	N	N	N	N	N	N	N	N	440-8i + OB NVMe
33-1	2	0	4	0	0	2	0	4x AnyBay G4 (BT1P)	2x SAS/SATA (B8MY)	N	N	N	N	N	N	N	N	N	N	N	N	N	N	(5350-8i or 9350-8i) + OB NVMe
33-2	2									N	N	N	N	N	N	N	N	N	N	N	N	N	N	4350-8i + OB NVMe
33-3	2									N	N	N	N	N	N	N	N	N	N	N	N	N	N	(940-8i or 540-8i) + OB NVMe
33-4	2									N	N	N	N	N	N	N	N	N	N	N	N	N	N	440-8i + OB NVMe
35-1	2	0	4	0	0	0	0	4x AnyBay G4 (BT1P)	None	N	N	N	N	N	N	N	Y	Y	Y	Y	Y	Y	Y	(5350-8i or 9350-8i) + OB NVMe
35-2	2									N	N	N	N	N	N	N	Y	Y	Y	Y	Y	Y	Y	4350-8i + OB NVMe
35-3	2									N	N	N	N	N	N	N	Y	Y	Y	Y	Y	Y	Y	(940-8i or 540-8i) + OB NVMe
35-4	2									N	N	N	N	N	N	N	Y	Y	Y	Y	Y	Y	Y	440-8i + OB NVMe
36-1	2	0	4	0	0	0	2	4x AnyBay G4 (BT1P)	2x NVMe (BDY6)	N	N	N	N	N	N	N	N	N	N	N	N	N	N	(5350-8i or 9350-8i) + OB NVMe
36-2	2									N	N	N	N	N	N	N	N	N	N	N	N	N	N	4350-8i + OB NVMe
36-3	2									N	N	N	N	N	N	N	N	N	N	N	N	N	N	(940-8i or 540-8i) + OB NVMe
36-4	2									N	N	N	N	N	N	N	N	N	N	N	N	N	N	440-8i + OB NVMe
37-1	2	0	4	0	0	2	0	4x AnyBay G4 (BT1P)	2x SAS/SATA (B8MY)	N	N	N	N	N	N	N	N	N	N	N	N	N	N	(5350-8i or 9350-8i) + OB NVMe
37-2	2									N	N	N	N	N	N	N	N	N	N	N	N	N	N	4350-8i + OB NVMe
37-3	2									N	N	N	N	N	N	N	N	N	N	N	N	N	N	(940-8i or 540-8i) + OB NVMe
37-4	2									N	N	N	N	N	N	N	N	N	N	N	N	N	N	440-8i + OB NVMe
39-1	2	0	0	4	0	0	0	4x NVMe G4 (BT1Q)	None	N	N	N	N	N	N	N	Y	Y	Y	Y	Y	Y	Y	OB NVMe
39-2	2	0	0	4	0	0	2	4x NVMe G4 (BT1Q)	2x NVMe (BDY6)	N	N	N	N	N	N	N	N	N	N	N	N	N	N	OB NVMe
40-1	2	0	0	4	0	0	0	4x NVMe G4 (BT1Q)	None	N	N	N	N	N	N	N	Y	Y	Y	Y	Y	Y	Y	OB NVMe

Config	CPUs	Front 2.5"				Rear 2.5"		Front backplane	Rear backplane	M.2						7mm				Supported controllers					
		SAS/SATA	AnyBay	NVMe	EDSFF	SAS/SATA	NVMe			M.2 x4 SATA/NVMe Non-RAID	M.2 x4 SATA/NVMe with SFF RAID	M.2 x1 SATA Non-RAID	M.2 x1 NVMe Non-RAID	M.2 NVMe RAID	M.2 SATA/NVMe RAID	7mm SATA Non-RAID	7mm NVMe Non-RAID	7mm NVMe RAID	7mm SATA/NVMe RAID		7mm SATA with SFF RAID 5350-8i	7mm NVMe with SFF RAID 540-8i			
40-2	2	0	0	4	0	0	2	4x NVMe G4 (BT1Q)	2x NVMe (BDY6)	N	N	N	N	N	N	N	N	N	N	N	N	N	N	N	OB NVMe
41-1	2	0	0	2	0	0	0	2x NVMe G4 (BU19)	None	N	N	N	N	N	N	N	Y	Y	Y	Y	Y	Y	Y	Y	OB NVMe
41-2	2	0	0	2	0	0	2	2x NVMe G4 (BU19)	2x NVMe (BDY6)	N	N	N	N	N	N	N	N	N	N	N	N	N	N	N	OB NVMe
44-1	2	0	0	4	0	0	0	4x NVMe G4 (BV8J)	None	N	N	N	N	N	N	N	Y	Y	Y	Y	Y	Y	Y	Y	OB NVMe
44-2	2	0	0	4	0	0	2	4x NVMe G4 (BV8J)	2x NVMe (BDY6)	N	N	N	N	N	N	N	N	N	N	N	N	N	N	N	OB NVMe

Field upgrades

Topics in this section:

- [2.5-inch and 3.5-inch drive bay upgrades](#)
- [7mm drive bay upgrades](#)
- [Upgrades to Internal \(CFF\) RAID adapter](#)
- [2.5-inch drive bay fillers](#)

2.5-inch and 3.5-inch drive bay upgrades

The SR645 V3 is orderable without drive bays, allowing you to add a backplane, cabling and controllers as field upgrades. Rear backplane kits included cables, however for front drive bays, the backplane kits do not include cables and must be ordered separately. The following table summarizes the option part numbers you will need to order for each available drive configuration.

For more information about the backplane kits and cable kits, see the Lenovo Server Options site: https://serveroption.lenovo.com/cable_kit_options/

Tip: There is no upgrade path to add drive bays if the SR645 V3 already has a backplane, without removing the existing backplane. For example, you cannot upgrade a 4x 2.5-inch drive bay to 8 bays without first removing the existing backplane.

Table 34. Front drive bay field upgrades for servers without drive bays

Desired drive configuration (starting from zero bays)	Backplane and cable kits required (all required)
Front drive bays - 3.5-inch	

Desired drive configuration (starting from zero bays)	Backplane and cable kits required (all required)
2xSATA+2NVMe/SATA or 4x3.5" AnyBay	<ol style="list-style-type: none"> 1. 4XH7A83853, ThinkSystem V3 1U 4x3.5" AnyBay Backplane Option Kit 2. 4X97A84610, ThinkSystem SR645 V3 4x3.5" AnyBay Backplane SAS/SATA Cable Option Kit 3. 4X97A84611, ThinkSystem SR645 V3 4x3.5" AnyBay Backplane PCIe Cable Option Kit
4x3.5" SATA or 4x3.5" SAS/SATA	<ol style="list-style-type: none"> 1. 4XH7A83854, ThinkSystem V3 1U 4x3.5" SAS/SATA Backplane Option Kit 2. 4X97A84609, ThinkSystem SR645 V3 4x3.5" SAS/SATA Backplane Cable Option kit
4x3.5" U.3 Tri-Mode	<ol style="list-style-type: none"> 1. 4XH7A83853, ThinkSystem V3 1U 4x3.5" AnyBay Backplane Option Kit 2. 4X97A84609, ThinkSystem SR645 V3 4x3.5" SAS/SATA Backplane Cable Option kit
Front drive bays - 2.5-inch	
8x2.5 SATA or 8x2.5 SAS/SATA	<ol style="list-style-type: none"> 1. 4XH7A83850, ThinkSystem V3 1U 8x2.5" SAS/SATA Backplane Option Kit 2. 4X97A84613, ThinkSystem SR645 V3 8x2.5" SAS/SATA Backplane Cable Option Kit
6SAS/SATA+4AnyBay Gen5	<ol style="list-style-type: none"> 1. 4XH7A87140, ThinkSystem V3 1U 6x2.5" SAS/SATA+4xGen5 AnyBay Backplane Option Kit 2. 4X97A87600, ThinkSystem SR645 V3 10x2.5" Anybay Backplane SAS/SATA Gen5 Cable Option Kit 3. 4X97A87601, ThinkSystem SR645 V3 10x2.5" AnyBay Backplane NVMe Gen5 Cable Option Kit
6SAS/SATA+2AnyBay +2NVMe Gen5	<ol style="list-style-type: none"> 1. 4XH7A87141, ThinkSystem V3 1U 6x2.5" SAS/SATA+2xGen5 NVMe+2xGen5 AnyBay Backplane Option Kit 2. 4X97A87600, ThinkSystem SR645 V3 10x2.5" Anybay Backplane SAS/SATA Gen5 Cable Option Kit 3. 4X97A87601, ThinkSystem SR645 V3 10x2.5" AnyBay Backplane NVMe Gen5 Cable Option Kit
10x2.5 AnyBay	<ol style="list-style-type: none"> 1. 4XH7A83859, ThinkSystem V3 1U 10x2.5" AnyBay Backplane Option Kit 2. 4X97A84614, ThinkSystem SR645 V3 Gen4 10x2.5" AnyBay Backplane PCIe Cable Option Kit 3. 4X97A84615, ThinkSystem SR645 V3 Gen4 10x2.5" AnyBay Backplane SAS/SATA Cable Option Kit
10x2.5 AnyBay Gen5	<ol style="list-style-type: none"> 1. 4XH7A83851, ThinkSystem V3 1U 10x2.5" AnyBay Backplane Gen5 Option Kit 2. 4X97A87600, ThinkSystem SR645 V3 10x2.5" Anybay Backplane SAS/SATA Gen5 Cable Option Kit 3. 4X97A87601, ThinkSystem SR645 V3 10x2.5" AnyBay Backplane NVMe Gen5 Cable Option Kit
8xU.3 Tri-Mode or 10xU.3 Tri-Mode	<ol style="list-style-type: none"> 1. 4XH7A83859, ThinkSystem V3 1U 10x2.5" AnyBay Backplane Option Kit 2. 4X97A84615, ThinkSystem SR645 V3 Gen4 10x2.5" AnyBay Backplane SAS/SATA Cable Option Kit
10x2.5 NVMe	<ol style="list-style-type: none"> 1. 4XH7A87142, ThinkSystem V3 1U 10x2.5" NVMe Backplane Gen4 Option Kit 2. 4X97A84614, ThinkSystem SR645 V3 Gen4 10x2.5" AnyBay Backplane PCIe Cable Option Kit
10x2.5 NVMe Gen5	<ol style="list-style-type: none"> 1. 4XH7A87139, ThinkSystem V3 1U 10x2.5" NVMe Backplane Gen5 Option Kit 2. 4X97A87601, ThinkSystem SR645 V3 10x2.5" AnyBay Backplane NVMe Gen5 Cable Option Kit
4x2.5 SAS/SATA	<ol style="list-style-type: none"> 1. 4XH7A83855, ThinkSystem V3 1U 4x2.5" SAS/SATA Backplane Option Kit 2. 4X97A84620, ThinkSystem SR645 V3 4x2.5 SAS/SATA Backplane Cable Option Kit
4x2.5 NVMe Gen4	<ol style="list-style-type: none"> 1. 4XH7A83852, ThinkSystem V3 1U 4x2.5" NVMe Backplane Option Kit 2. 4X97A87042, ThinkSystem SR645 V3 4x2.5" NVMe Gen4 Cable Option Kit

Desired drive configuration (starting from zero bays)	Backplane and cable kits required (all required)
4x2.5 NVMe Gen5	<ol style="list-style-type: none"> 4XH7A86277, ThinkSystem V3 1U 4x2.5" NVMe Backplane Gen5 Option Kit 4X97A86276, ThinkSystem SR645 V3 4x2.5" NVMe Backplane PCIe Gen5 Cable Option Kit
Rear drive bays - 2.5-inch	
2x 2.5-inch SAS/SATA	1. 4XH7A87640, ThinkSystem SR645 V3 2x2.5" SAS/SATA Backplane Option Kit (includes cables)
2x 2.5-inch NVMe	1. 4XH7A87641, ThinkSystem SR645 V3 Rear 2x2.5" NVMe Backplane Option Kit (includes cables)

When adding drive bays, you will also need to add the appropriate storage controller(s). Consult the tables in the [Storage configurations](#) section to determine what controller sections are supported and what additional controllers you will need. Controllers are described in the [Controllers for internal storage](#) section.

7mm drive bay upgrades

For field upgrades to add 7mm drive bays, order one of the part numbers listed in the following table.

Table 35. Field upgrades for 7mm drives

Part number	Description	Purpose
7mm Drive Enablement Kits		
4XH7A93166	ThinkSystem SR635 V3/SR645 V3 7mm RAID B540p-2HS SATA/NVMe Enablement Kit <ul style="list-style-type: none"> 7mm drive cage 7mm drive backplane with cables for onboard connections 2x drive bay fillers 	7mm drive bays for SATA or NVMe drive support. RAID support is integrated into the adapter using an onboard Broadcom RAID controller.

Upgrades to Internal (CFF) RAID adapter

It is also supported to upgrade a server from an onboard SATA controller to an internal (CFF) RAID adapter, without changing any backplanes. In addition to ordering the RAID adapter, you will also need to order the cable kit listed in the following table.

Table 36. Cable kit for Internal (CFF) RAID adapter

Part number	Description
4X97A87602	ThinkSystem SR645 V3 Internal Raid Adapter Cable Option Kit

2.5-inch drive bay fillers

Backplane option kits include the necessary drive bay fillers, however if needed, additional blanks can be ordered as listed in the following table.

Table 37. Drive bay fillers for 2.5-inch bays

Part number	Description
4XH7A99569	ThinkSystem 2.5" 1x1 HDD Filler by 8 units (contains 8x single drive-bay fillers)

RAID flash power module (supercap) support

The SR645 V3 supports 1x RAID adapter flash power module (supercap). The adapters that this applies to are as follows:

- Any supported RAID 9350 adapter
- Any supported RAID 940 adapter, including RAID 940-8e

There are two possible locations for supercaps, depending on the front drive bays (2.5-inch or 3.5-inch) and the size of the processor heatsinks. Details are summarized in the following table. Location references are shown in the figure below.

Table 38. Supercap support

Front drive configuration	Processor heatsinks	Number of adapters & supercaps	Location of supercaps
2.5-inch	High Performance	1	Front of server behind operator panel ❶
	Closed-loop liquid*	1	Installed in slot 3 attached to Riser 2 ❷
3.5-inch	High Performance	1	Installed in slot 3 attached to Riser 2 ❷
2.5-inch with front slots	High Performance	1	Front of server behind operator panel ❶

* The Closed-loop liquid heatsink is only supported with 2.5-inch front drives without front PCIe slots

The locations where supercaps are installed is shown in the following figure.

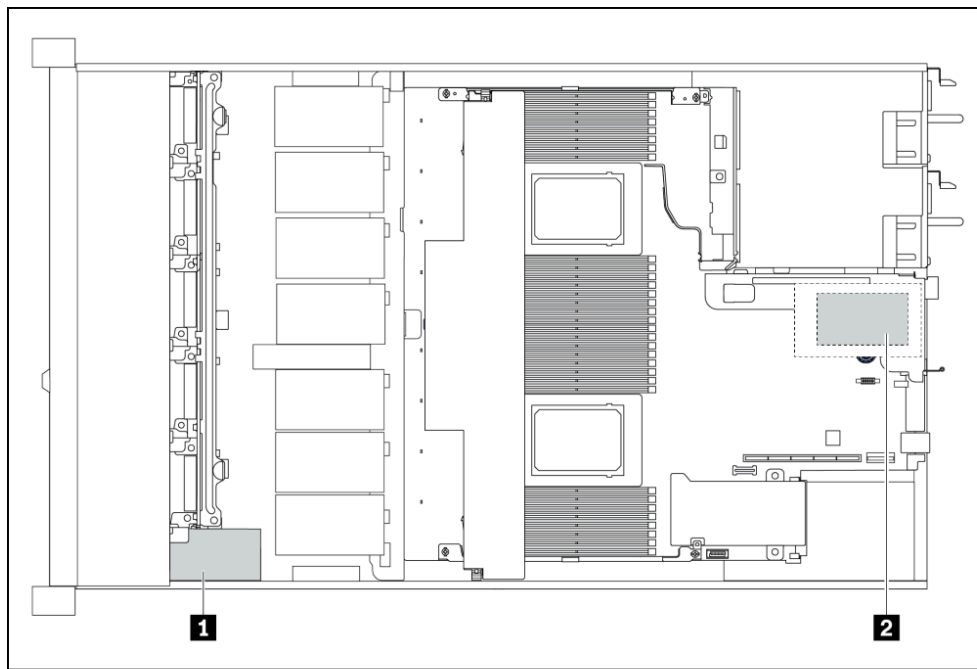

Figure 15. Location of the supercaps in the SR645 V3

If you plan to add one of the RAID adapters that includes a supercap as a field upgrade, then you will also need to order a supercap installation kit for the power module. For CTO orders, the components in the installation kit are automatically derived when you select the RAID adapter.

When adding a RAID adapter and supercap as a field upgrade, order the supercap installation kit list listed in the following table.

Table 39. RAID Flash Power Module installation kits

Part number	Feature code	Description	Maximum supported
4M17A61304	BK70	ThinkSystem V3 1U Supercap Holder Kit (For use in position ❶ at the front of the server)	1

Part number	Feature code	Description	Maximum supported
4XF7A85032	BK5T	ThinkSystem V3 1U Supercap Holder Kit for PCIe Slot (Low profile adapter form factor for use in slot 3, position ②)	1

M.2 drives

The SR645 V3 supports one or two M.2 form-factor SATA or NVMe drives for use as an operating system boot solution or as additional storage.

The M.2 drives install into an M.2 module which is mounted horizontally in the server in front of the fans as shown in the [Internal view](#) of the server. In configurations with 2.5-inch front drive bays, the M.2 module is position between the drive bays and the fans. In configurations with 3.5-inch front drive bays, the M.2 module is mounted on top of the front drive bays.

The supported M.2 modules are listed in the following table. For field upgrades see the [M.2 field upgrades](#) section below.

Table 40. M.2 modules

Part number	Feature code	Description	Top Choice Express	SATA drives	NVMe drives	RAID	Maximum supported	Windows 10/11 support
4Y37A09738	B5XJ	ThinkSystem M.2 SATA/NVMe 2-Bay Enablement Kit	TCE	Yes	Yes (x1 lane)	No	1	Supported
4Y37A79663	BM8X	ThinkSystem M.2 SATA/x4 NVMe 2-Bay Adapter	TCE	Yes	Yes (x4 lanes)	Optional	1	Supported
4Y37A09750	B8P9	ThinkSystem M.2 NVMe 2-Bay RAID Adapter	TCE	No	Yes (x1 lane)	Integrated (Marvell)	1	No
4Y37A90063	BYFF	ThinkSystem M.2 RAID B540i-2i SATA/NVMe Adapter	TCE	Yes	Yes (x1 lane)	Integrated (Broadcom)	1	No

The ThinkSystem M.2 SATA/x4 NVMe 2-Bay Adapter (4Y37A79663) optionally supports RAID with the addition of a separate RAID adapter is required. For CTO orders, ordering information is listed in the following table to derive the required RAID adapter.

Table 41. CTO feature codes to select M.2 RAID (ThinkSystem M.2 SATA/x4 NVMe 2-Bay Adapter only)

Feature code	Description	Top Choice Express	RAID support	Maximum supported	Windows 10/11 support
BT7P	ThinkSystem RAID 540-8i for M.2/7mm NVMe Boot Enablement	Not TCE	NVMe	1	Supported

Configuration notes:

- M.2 is not supported with all storage configurations - see [Storage configurations](#) for details.
- For ThinkSystem M.2 SATA/NVMe 2-Bay Enablement Kit (4Y37A09738):
 - RAID is not supported
 - The installation of at least one M.2 drive is required. In the configurator, at least one M.2 drive must be selected

- For ThinkSystem M.2 SATA/x4 NVMe 2-Bay Adapter (4Y37A79663):
 - The support of RAID-1 with the M.2 drives requires an additional RAID adapter that is installed in PCIe slot 2:
 - RAID support for M.2 NVMe drives requires a RAID 540-8i adapter operating in Tri-Mode (feature BT7P)
 - The RAID adapter used for M.2 drive support cannot be configured for use with other drive bays (not even with 7mm)
 - M.2 without a RAID adapter + 7mm SATA are mutually exclusive: they are not supported together in the same configuration
 - If RAID support is not required, the M.2 adapter connects to an onboard port. No additional adapter is required
 - The M.2 adapter is not supported with the following storage configurations due to physical limitations:
 - Configurations with 3.5-inch front drive bays
 - Configurations with EDSFF drive bays
- For ThinkSystem M.2 NVMe 2-Bay RAID Adapter (4Y37A09750):
 - RAID is implemented using an onboard Marvell 88NR2241 NVMe RAID controller
- For ThinkSystem M.2 RAID B540i-2i SATA/NVMe Adapter (4Y37A90063):
 - RAID is implemented using an onboard Broadcom controller
- M.2 and 7mm are supported together in certain combinations. See the [7mm and M.2 supported combinations](#) section

The ThinkSystem M.2 SATA/NVMe 2-Bay Enablement Kit has the following features:

- Supports one or two M.2 drives, either SATA or NVMe
- When two drives installed, they must be either both SATA or both NVMe
- Support 42mm, 60mm, 80mm and 110mm drive form factors (2242, 2260, 2280 and 22110)
- On the SR645 V3, no RAID support
- Either 6Gbps SATA or PCIe 3.0 x1 interface to the drives depending on the drives installed
- Supports monitoring and reporting of events and temperature through I2C
- Firmware update via Lenovo firmware update tools
- When connected to a separate PCIe RAID adapter, supports SED drive encryption via the RAID adapter, otherwise no SED support

The ThinkSystem M.2 SATA/x4 NVMe 2-Bay Adapter has the following features:

- Supports one or two M.2 drives, either SATA or NVMe
- When two drives installed, they must be either both SATA or both NVMe
- Support 42mm, 60mm, 80mm and 110mm drive form factors (2242, 2260, 2280 and 22110)
- No onboard RAID; RAID functionality is provided by a separate adapter (SATA or NVMe)
- Either 6Gbps SATA or PCIe 4.0 x4 interface to the drives depending on the drives installed
- Supports monitoring and reporting of events and temperature through I2C
- Firmware update via Lenovo firmware update tools
- When connected to a separate PCIe RAID adapter, supports SED drive encryption via the RAID adapter, otherwise no SED support

The ThinkSystem M.2 NVMe 2-Bay RAID Adapter (4Y37A09750) has the following features:

- Supports one or two NVMe M.2 drives
- Support 42mm, 60mm, 80mm and 110mm drive form factors (2242, 2260, 2280 and 22110)
- RAID support via an onboard Marvell 88NR2241 NVMe RAID Controller
- With 1 drive, supports single-drive RAID-0
- With 2 drives, supports 2-drive RAID-0, 2-drive RAID-1, or two single-drive RAID-0 arrays
- PCIe 3.0 x2 host interface; PCIe 3.0 x1 connection to each drive
- Management and configuration support via UEFI and OS-based tools
- Supports monitoring and reporting of events and temperature through I2C
- Firmware update via Lenovo firmware update tools
- No support for SED drive encryption

The ThinkSystem M.2 RAID B540i-2i SATA/NVMe Adapter (4Y37A90063) has the following features:

- Supports one or two M.2 drives, either SATA or NVMe
- Support 42mm, 60mm, 80mm and 110mm drive form factors (2242, 2260, 2280 and 22110)
- RAID support via an onboard Broadcom SAS3808N RAID Controller
- With 1 drive, supports JBOD
- With 2 drives, supports 2-drive RAID-0, 2-drive RAID-1, or JBOD
- PCIe 4.0 x2 host interface; PCIe 4.0 x1 connection to each drive
- Management and configuration support via UEFI and OS-based tools
- Supports monitoring and reporting of events and temperature
- Firmware update via Lenovo firmware update tools
- Supports SED drive encryption

M.2 field upgrades

For field upgrades, the SR645 V3 also requires additional cables necessary to connect the M.2 to either the system board or RAID adapter.

Ordering information is listed in the following table. Note that the cable kit contains the necessary cables for all supported M.2 adapters, including the cables needed to connect to a supported RAID adapter (540-8i or 5350-8i).

Table 42. Cable kit for M.2 drive support

Part number	Description
M.2 Cable Kits	
4X97A87123	ThinkSystem SR645 V3 M.2 Enablement Cable Option Kit
RAID adapters for M.2 RAID support (for 4Y37A79663 only)	
4Y37A78834	ThinkSystem RAID 540-8i PCIe Gen4 12Gb Adapter (NVMe M.2 support using Tri-Mode) Tip: Once the 540-8i adapter is installed, it will need to be configured to operate in Tri-mode to enable NVMe RAID.

SED encryption key management with SKLM

The server supports self-encrypting drives (SEDs) as listed in the [Internal drive options](#) section. To effectively manage a large deployment of these drives in Lenovo servers, IBM Security Key Lifecycle Manager (SKLM) offers a centralized key management solution.

The IBM Security Key Lifecycle Manager software is available from Lenovo using the ordering information listed in the following table.

Table 43. IBM Security Key Lifecycle Manager licenses

Part number	Feature	Description
SKLM Basic Edition		
7S0A007FWW	S874	IBM Security Key Lifecycle Manager Basic Edition Install License + SW Subscription & Support 12 Months
7S0A008VWW	SDJR	IBM Security Key Lifecycle Manager Basic Edition Install License + SW Subscription & 3 Years Of Support
7S0A008WWW	SDJS	IBM Security Key Lifecycle Manager Basic Edition Install License + SW Subscription & 4 Years Of Support
7S0A008XWW	SDJT	IBM Security Key Lifecycle Manager Basic Edition Install License + SW Subscription & 5 Years Of Support
SKLM For Raw Decimal Terabyte Storage		
7S0A007HWW	S876	IBM Security Key Lifecycle Manager For Raw Decimal Terabyte Storage Resource Value Unit License + SW Subscription & Support 12 Months
7S0A008YWW	SDJU	IBM Security Key Lifecycle Manager For Raw Decimal Terabyte Storage Resource Value Unit License + SW Subscription & 3 Years Of Support
7S0A008ZWW	SDJV	IBM Security Key Lifecycle Manager For Raw Decimal Terabyte Storage Resource Value Unit License + SW Subscription & 4 Years Of Support
7S0A0090WW	SDJW	IBM Security Key Lifecycle Manager For Raw Decimal Terabyte Storage Resource Value Unit License + SW Subscription & 5 Years Of Support
SKLM For Raw Decimal Petabyte Storage		
7S0A007KWW	S878	IBM Security Key Lifecycle Manager For Raw Decimal Petabyte Storage Resource Value Unit License + SW Subscription & Support 12 Months
7S0A0091WW	SDJX	IBM Security Key Lifecycle Manager For Raw Decimal Petabyte Storage Resource Value Unit License + SW Subscription & 3 Years Of Support
7S0A0092WW	SDJY	IBM Security Key Lifecycle Manager For Raw Decimal Petabyte Storage Resource Value Unit License + SW Subscription & 4 Years Of Support
7S0A0093WW	SDJZ	IBM Security Key Lifecycle Manager For Raw Decimal Petabyte Storage Resource Value Unit License + SW Subscription & 5 Years Of Support
SKLM For Usable Decimal Terabyte Storage		
7S0A007MWW	S87A	IBM Security Key Lifecycle Manager For Usable Decimal Terabyte Storage Resource Value Unit License + SW Subscription & Support 12 Months
7S0A0094WW	SDK0	IBM Security Key Lifecycle Manager For Usable Decimal Terabyte Storage Resource Value Unit License + SW Subscription & 3 Years In Support
7S0A0095WW	SDK1	IBM Security Key Lifecycle Manager For Usable Decimal Terabyte Storage Resource Value Unit License + SW Subscription & 4 Years In Support
7S0A0096WW	SDK2	IBM Security Key Lifecycle Manager For Usable Decimal Terabyte Storage Resource Value Unit License + SW Subscription & 5 Years In Support
SKLM For Usable Decimal Petabyte Storage		
7S0A007PWW	S87C	IBM Security Key Lifecycle Manager For Usable Decimal Petabyte Storage Resource Value Unit License + SW Subscription & Support 12 Months

Part number	Feature	Description
7S0A0097WW	SDK3	IBM Security Key Lifecycle Manager For Usable Decimal Petabyte Storage Resource Value Unit License + SW Subscription & 3 Years Of Support
7S0A0098WW	SDK4	IBM Security Key Lifecycle Manager For Usable Decimal Petabyte Storage Resource Value Unit License + SW Subscription & 4 Years Of Support
7S0A0099WW	SDK5	IBM Security Key Lifecycle Manager For Usable Decimal Petabyte Storage Resource Value Unit License + SW Subscription & 5 Years Of Support

Controllers for internal storage

The SR645 V3 offers a variety of controller options for internal drives:

- For 2.5-inch and 3.5-inch drives:
 - Onboard SATA ports (feature AVUX)
 - Onboard NVMe ports (feature BC4V)
 - PCIe Retimer adapter for NVMe drives (PCIe slot-based)
 - RAID adapters and HBAs for SAS/SATA drives (PCIe slot-based)
 - RAID adapters and HBAs for SAS/SATA drives (cabled in a dedicated space)
- For 7mm drive bays in the rear of the server (see the [7mm drives](#) section)
 - SATA controller integrated into the 7mm drive bay enclosure
 - NVMe controller integrated into the 7mm drive bay enclosure
- For M.2 drives internal to the server (see [M.2 drives](#) section)
 - SATA controller integrated on the M.2 adapters
 - NVMe controller integrated on the M.2 adapters

As well as supporting RAID adapters and HBAs that install in a PCIe slot, the SR645 V3 with 2.5-inch front drive bays supports a custom form factor (CFF) adapter that is mounted in the server and cabled to one of the onboard NVMe ports. CFF adapters are not supported with 3.5-inch front drives due to a lack of physical space.

The following table lists the adapters used for the internal storage of the server. The table includes a Top Choice Express column; for CTO orders, select a TCE component for faster delivery. See the [Top Choice](#) section for more information.

Table 44. Internal Storage adapter support

Part number	Feature code	Description	Top Choice Express	RAID levels	Power module (supercap)	Max qty	Slots supported	Windows 10/11 support
Onboard controllers								
CTO only	AVUX	On Board SATA AHCI Mode	TCE	None	No	1	N/A	Supported
CTO only	BC4V	Non RAID NVMe	TCE	None	No	1	N/A	Supported
12Gb SAS/6Gb SATA RAID adapters - Broadcom PCIe 4.0 adapters								
4Y37A78834	BMFT	ThinkSystem RAID 540-8i PCIe Gen4 12Gb Adapter	TCE	0, 1, 10	No	1	1	Supported
4Y37A78835	BNAX	ThinkSystem RAID 540-16i PCIe Gen4 12Gb Adapter	Not TCE	0, 1, 10	No	1	1	Supported
4Y37A09728	B8NY	ThinkSystem RAID 940-8i 4GB Flash PCIe Gen4 12Gb Adapter	TCE	0, 1, 10, 5, 50, 6, 60	Included	1	1	Supported
4Y37A09729	B8NW	ThinkSystem RAID 940-8i 8GB Flash PCIe Gen4 12Gb Adapter	TCE	0, 1, 10, 5, 50, 6, 60	Included	1	1	Supported
4Y37A78600	BM35	ThinkSystem RAID 940-16i 4GB Flash PCIe Gen4 12Gb Adapter	TCE	0, 1, 10, 5, 50, 6, 60	Included	1	1	Supported
4Y37A09730	B8NZ	ThinkSystem RAID 940-16i 8GB Flash PCIe Gen4 12Gb Adapter	TCE	0, 1, 10, 5, 50, 6, 60	Included	1	1	Supported

Part number	Feature code	Description	Top Choice Express	RAID levels	Power module (supercap)	Max qty	Slots supported	Windows 10/11 support
4Y37A09735	B8P0	ThinkSystem RAID 940-16i 8GB Flash PCIe Gen4 12Gb Internal Adapter	TCE	0, 1, 10, 5, 50, 6, 60	Included	1*	None (cabled)	Supported
12Gb SAS/6Gb SATA HBAs - Broadcom PCIe 4.0 adapters								
4Y37A78601	BM51	ThinkSystem 440-8i SAS/SATA PCIe Gen4 12Gb HBA	TCE	None	No	1	1	No
4Y37A78602	BM50	ThinkSystem 440-16i SAS/SATA PCIe Gen4 12Gb HBA	TCE	None	No	1	1	No
4Y37A09725	B8P1	ThinkSystem 440-16i SAS/SATA PCIe Gen4 12Gb Internal HBA	Not TCE	None	No	1*	None (cabled)	No
NVMe using Tri-Mode (NVMe x1) (no support for NVMe U.2 drives)								
4Y37A09728	BGM1	ThinkSystem RAID 940-8i 4GB Flash PCIe Gen4 12Gb Adapter	TCE	0, 1, 10, 5, 50, 6, 60	Included	1	1	Supported
4Y37A09729	BGM0	ThinkSystem RAID 940-8i 8GB Flash PCIe Gen4 12Gb Adapter	Not TCE	0, 1, 10, 5, 50, 6, 60	Included	1	1	Supported
4Y37A78600	BM36	ThinkSystem RAID 940-16i 4GB Flash PCIe Gen4 12Gb Adapter	TCE	0, 1, 10, 5, 50, 6, 60	Included	1	1	Supported
4Y37A09730	BDY4	ThinkSystem RAID 940-16i 8GB Flash PCIe Gen4 12Gb Adapter	TCE	0, 1, 10, 5, 50, 6, 60	Included	1	1	Supported
NVMe using x4 interface								
4C57A65446	B98C	ThinkSystem 4-Port PCIe Gen4 NVMe Retimer Adapter (4x drives)	TCE	None	No	1	1	Supported

* Only supported with 2.5-inch front drive bays. Not supported in configurations with 3.5-inch front drive bays.

** This adapter is currently not available for CTO orders; it is only available as an option part number for field upgrades

Configuration notes:

- **Internal (CFF) adapter support:** Internal (CFF) RAID adapters and HBAs are only supported with 2.5-inch front drive bays. They are not supported in configurations with 3.5-inch front drive bays due to physical restrictions.
- **Supercap support limits the number of RAID adapters installable:** The table lists whether the adapter includes a power module (supercap) to power the flash memory. The server supports only 1 supercap, the location of which depends on the server configuration as described in the [RAID flash power module \(supercap\) support](#) section. The number of supercaps supported determines the maximum number of RAID adapters with flash that can be installed in the server.
- **Field upgrades:** If you are adding a RAID adapter with supercap to the server as a field upgrade, you may need a supercap holder as described in the [RAID flash power module \(supercap\) support](#) section.
- **7mm drive support:** The storage adapters listed in the table below do *not* provide connectivity to the 7mm drive bays that are optionally available at the rear of the server. The 7mm drives have their own independent RAID controller. See the [Rear 2.5-inch and 7mm drive bays](#) section for details.

The onboard SATA controller has the following features:

- Controller integrated into the AMD processor
- JBOD only; no RAID support
- Supports up to 12 SATA drives in the SR645 V3
- Supports HDDs and SSDs; can be mixed

For specifications about the RAID adapters and HBAs supported by the SR645 V3, see the ThinkSystem RAID Adapter and HBA Reference, available from:

<https://lenovopress.lenovo.com/lp1288-thinksystem-raid-adapter-and-hba-reference#sr645-v3-support=SR645%2520V3>

For more information about each of the adapters, see the product guides in the RAID adapters or HBA sections of the Lenovo Press web site:

<https://lenovopress.com/servers/options/raid>

<https://lenovopress.com/servers/options/hba>

Tri-Mode support - RAID 940 adapters

The RAID 940 adapters support NVMe through a feature named Tri-Mode support (or Trimode support). This feature enables the use of NVMe U.3 drives at the same time as SAS and SATA drives. Tri-Mode requires an AnyBay backplane. Cabling of the controller to the backplanes is the same as with SAS/SATA drives, and the NVMe drives are connected via a PCIe x1 link to the controller.

NVMe drives connected using Tri-Mode support provide better performance than SAS or SATA drives: A SATA SSD has a data rate of 6Gbps, a SAS SSD has a data rate of 12Gbps, whereas an NVMe U.3 Gen 4 SSD with a PCIe x1 link will have a data rate of 16Gbps. NVMe drives typically also have lower latency and higher IOPS compared to SAS and SATA drives. Tri-Mode is supported with U.3 NVMe drives and requires an AnyBay backplane.

Tri-Mode requires U.3 drives: Only NVMe drives with a U.3 interface are supported. U.2 drives are not supported. See the [Internal drive options](#) section for the U.3 drives supported by the server.

Internal drive options

The following tables list the drive options for internal storage of the server.

2.5-inch hot-swap drives:

- [2.5-inch hot-swap 12 Gb SAS HDDs](#)
- [2.5-inch hot-swap 24 Gb SAS SSDs](#)
- [2.5-inch hot-swap 6 Gb SATA SSDs](#)
- [2.5-inch hot-swap PCIe 5.0 NVMe SSDs](#)
- [2.5-inch hot-swap PCIe 4.0 NVMe SSDs](#)

2.5-inch 7mm hot-swap drives:

- [7mm 2.5-inch hot-swap 6 Gb SATA SSDs](#)
- [7mm 2.5-inch hot-swap PCIe 4.0 NVMe SSDs](#)

EDSFF hot-swap drives:

- [E1.S EDSFF hot-swap PCIe 4.0 NVMe SSDs](#)

3.5-inch hot-swap drives:

- [3.5-inch hot-swap 12 Gb SAS HDDs](#)
- [3.5-inch hot-swap 6 Gb SATA HDDs](#)
- [3.5-inch hot-swap 24 Gb SAS SSDs](#)
- [3.5-inch hot-swap 6 Gb SATA SSDs](#)
- [3.5-inch hot-swap PCIe 5.0 NVMe SSDs](#)
- [3.5-inch hot-swap PCIe 4.0 NVMe SSDs](#)

M.2 drives:

- [M.2 SATA drives](#)
- [M.2 PCIe 4.0 NVMe drives](#)

M.2 drive support: The use of M.2 drives requires an additional adapter as described in the [M.2 drives](#) subsection.

SED support: The tables include a column to indicate which drives support SED encryption. The encryption functionality can be disabled if needed. Note: Not all SED-enabled drives have "SED" in the description.

Table 45. 2.5-inch hot-swap 12 Gb SAS HDDs

Part number	Feature code	Description	Top Choice Express	SED support	Max Qty
2.5-inch hot-swap HDDs - 12 Gb SAS 10K					
7XB7A00025	AULZ	ThinkSystem 2.5" 600GB 10K SAS 12Gb Hot Swap 512n HDD	Not TCE	No	12
7XB7A00027	AUM1	ThinkSystem 2.5" 1.2TB 10K SAS 12Gb Hot Swap 512n HDD	TCE	No	12
7XB7A00028	AUM2	ThinkSystem 2.5" 1.8TB 10K SAS 12Gb Hot Swap 512e HDD	Not TCE	No	12
4XB7A83970	BRG7	ThinkSystem 2.5" 2.4TB 10K SAS 12Gb Hot Swap 512e HDD v2	TCE	No	12
2.5-inch hot-swap SED HDDs - 12 Gb SAS 10K					
7XB7A00031	AUM5	ThinkSystem 2.5" 600GB 10K SAS 12Gb Hot Swap 512n HDD SED	Not TCE	Support	12

Part number	Feature code	Description	Top Choice Express	SED support	Max Qty
7XB7A00033	B0YX	ThinkSystem 2.5" 1.2TB 10K SAS 12Gb Hot Swap 512n HDD SED	TCE ⓘ	Support	12
4XB7A84038	BRG8	ThinkSystem 2.5" 2.4TB 10K SAS 12Gb Hot Swap 512e HDD FIPS v2	TCE ⓘ	Support	12

Table 46. 2.5-inch hot-swap 24 Gb SAS SSDs

Part number	Feature code	Description	Top Choice Express	SED support	Max Qty
2.5-inch hot-swap SSDs - 24 Gb SAS - Mixed Use/Mainstream (3-5 DWPD)					
4XB7B07612	CABL	ThinkSystem 2.5" VA 800GB Mixed Use SAS 24Gb HS SSD	Not TCE	Support	12
4XB7B07613	CABR	ThinkSystem 2.5" VA 1.6TB Mixed Use SAS 24Gb HS SSD	Not TCE	Support	12
4XB7B07614	CABQ	ThinkSystem 2.5" VA 3.2TB Mixed Use SAS 24Gb HS SSD	TCE	Support	12
4XB7B07615	CABK	ThinkSystem 2.5" VA 6.4TB Mixed Use SAS 24Gb HS SSD	TCE	Support	12
4XB7A97308	C4KR	ThinkSystem 2.5" PM7 1.6TB Mixed Use SAS 24Gb HS SSD FIPS	Not TCE	Support	12
2.5-inch hot-swap SSDs - 24 Gb SAS - Read Intensive/Entry/Capacity (<3 DWPD)					
4XB7B07600	CABS	ThinkSystem 2.5" VA 960GB Read Intensive SAS 24Gb HS SSD	TCE	Support	12
4XB7B07601	CABV	ThinkSystem 2.5" VA 1.92TB Read Intensive SAS 24Gb HS SSD	Not TCE	Support	12
4XB7B07602	CABT	ThinkSystem 2.5" VA 3.84TB Read Intensive SAS 24Gb HS SSD	TCE	Support	12
4XB7B07603	CABY	ThinkSystem 2.5" VA 7.68TB Read Intensive SAS 24Gb HS SSD	TCE	Support	12
4XB7B07604	CABX	ThinkSystem 2.5" VA 15.36TB Read Intensive SAS 24Gb HS SSD	Not TCE	Support	12
4XB7B07605	CABW	ThinkSystem 2.5" VA 30.72TB Read Intensive SAS 24Gb HS SSD	Not TCE	Support	12

Table 48. 2.5-inch hot-swap 6 Gb SATA SSDs

Part number	Feature code	Description	Top Choice Express	SED support	Max Qty
2.5-inch hot-swap SSDs - 6 Gb SATA - Mixed Use/Mainstream (3-5 DWPD)					
4XB7B09972	CBV9	ThinkSystem 2.5" VA 480GB Mixed Use SATA 6Gb HS SSD SED	TCE ⓘ	Support	12
4XB7B09973	CBV8	ThinkSystem 2.5" VA 960GB Mixed Use SATA 6Gb HS SSD SED	TCE ⓘ	Support	12
4XB7B09974	CBV7	ThinkSystem 2.5" VA 1.92TB Mixed Use SATA 6Gb HS SSD SED	Not TCE	Support	12
4XB7B09975	CBV6	ThinkSystem 2.5" VA 3.84TB Mixed Use SATA 6Gb HS SSD SED	Not TCE	Support	12
4XB7A90884	BYM2	ThinkSystem 2.5" VA 480GB Mixed Use SATA 6Gb HS SSD v2	TCE	No	12

Part number	Feature code	Description	Top Choice Express	SED support	Max Qty
4XB7A90885	BYM4	ThinkSystem 2.5" VA 960GB Mixed Use SATA 6Gb HS SSD v2	TCE	No	12
4XB7A90886	BYM5	ThinkSystem 2.5" VA 1.92TB Mixed Use SATA 6Gb HS SSD v2	Not TCE	No	12
4XB7A90887	BYM6	ThinkSystem 2.5" VA 3.84TB Mixed Use SATA 6Gb HS SSD v2	Not TCE	No	12
2.5-inch hot-swap SSDs - 6 Gb SATA - Read Intensive/Entry (<3 DWPD)					
4XB7B09967	CBVE	ThinkSystem 2.5" VA 480GB Read Intensive SATA 6Gb HS SSD SED	TCE ⓘ	Support	12
4XB7B09968	CBVD	ThinkSystem 2.5" VA 960GB Read Intensive SATA 6Gb HS SSD SED	TCE ⓘ	Support	12
4XB7B09969	CBVC	ThinkSystem 2.5" VA 1.92TB Read Intensive SATA 6Gb HS SSD SED	TCE ⓘ	Support	12
4XB7B09970	CBVB	ThinkSystem 2.5" VA 3.84TB Read Intensive SATA 6Gb HS SSD SED	TCE ⓘ	Support	12
4XB7B09971	CBVA	ThinkSystem 2.5" VA 7.68TB Read Intensive SATA 6Gb HS SSD SED	TCE ⓘ	Support	12
4XB7A90873	BYLR	ThinkSystem 2.5" VA 480GB Read Intensive SATA 6Gb HS SSD v2	TCE	No	12
4XB7A90874	BYLS	ThinkSystem 2.5" VA 960GB Read Intensive SATA 6Gb HS SSD v2	TCE	No	12
4XB7A90875	BYLT	ThinkSystem 2.5" VA 1.92TB Read Intensive SATA 6Gb HS SSD v2	TCE	No	12
4XB7A90876	BYLU	ThinkSystem 2.5" VA 3.84TB Read Intensive SATA 6Gb HS SSD v2	TCE	No	12
4XB7A90877	BYLV	ThinkSystem 2.5" VA 7.68TB Read Intensive SATA 6Gb HS SSD v2	Not TCE	No	12

Table 49. 2.5-inch hot-swap PCIe 5.0 NVMe SSDs

Part number	Feature code	Description	Top Choice Express	SED support	Max Qty
2.5-inch SSDs - U.2 PCIe 5.0 NVMe - Mixed Use/Mainstream (3-5 DWPD)					
4XB7A93097	C1WM	ThinkSystem 2.5" U.2 PM9D5a 800GB Mixed Use NVMe PCIe 5.0 x4 HS SSD	Not TCE	Support	12
4XB7A93127	C0ZR	ThinkSystem 2.5" U.2 VA 1.6TB Mixed Use NVMe PCIe 5.0 x4 HS SSD	TCE	Support	12
4XB7A93128	C0ZQ	ThinkSystem 2.5" U.2 VA 3.2TB Mixed Use NVMe PCIe 5.0 x4 HS SSD	TCE	Support	12
4XB7A93129	C0ZP	ThinkSystem 2.5" U.2 VA 6.4TB Mixed Use NVMe PCIe 5.0 x4 HS SSD	TCE	Support	12
4XB7A93130	C0ZN	ThinkSystem 2.5" U.2 VA 12.8TB Mixed Use NVMe PCIe 5.0 x4 HS SSD	Not TCE	Support	12
2.5-inch SSDs - U.3 PCIe 5.0 NVMe - Mixed Use/Mainstream (3-5 DWPD)					
4XB7A94637	C4D4	ThinkSystem 2.5" U.3 PM1745 1.6TB Mixed Use NVMe PCIe 5.0 x4 HS SSD	Not TCE	Support	12
2.5-inch SSDs - U.2 PCIe 5.0 NVMe - Read Intensive/Entry (<3 DWPD)					

Part number	Feature code	Description	Top Choice Express	SED support	Max Qty
4XB7B10396	CFD6	ThinkSystem 2.5" U.2 SN861 1.92TB Read Intensive NVMe PCIe 5.0 x4 HS SSD	Not TCE	Support	12
4XB7B10397	CFD5	ThinkSystem 2.5" U.2 SN861 3.84TB Read Intensive NVMe PCIe 5.0 x4 HS SSD	Not TCE	Support	12
4XB7B10398	CFD4	ThinkSystem 2.5" U.2 SN861 7.68TB Read Intensive NVMe PCIe 5.0 x4 HS SSD	Not TCE	Support	12
4XB7B10399	CFD3	ThinkSystem 2.5" U.2 SN861 15.36TB Read Intensive NVMe PCIe 5.0 x4 HS SSD	Not TCE	Support	12
4XB7B08330	CBSW	ThinkSystem 2.5" U.2 6550 30.72TB Read Intensive NVMe PCIe 5.0 x4 HS SSD	Not TCE	Support	12
4XB7B08331	CBSX	ThinkSystem 2.5" U.2 6550 61.44TB Read Intensive NVMe PCIe 5.0 x4 HS SSD	Not TCE	Support	12
4XB7B02475	C8DH	ThinkSystem 2.5" U.2 BM1743 15.36TB Read Intensive NVMe PCIe 5.0 x4 HS SSD	Not TCE	Support	12
4XB7B02406	C8DK	ThinkSystem 2.5" U.2 BM1743 30.72TB Read Intensive NVMe PCIe 5.0 x4 HS SSD	Not TCE	Support	12
4XB7B02407	C8DJ	ThinkSystem 2.5" U.2 BM1743 61.44TB Read Intensive NVMe PCIe 5.0 x4 HS SSD	Not TCE	Support	12
4XB7B09031	CBSY	ThinkSystem 2.5" U.2 BM1743 122.88TB Read Intensive NVMe PCIe 5.0 x4 HS SSD	Not TCE	Support	12
4XB7A93066	C0GK	ThinkSystem 2.5" U.2 PM9D3a 960GB Read Intensive NVMe PCIe 5.0 x4 HS SSD	Not TCE	Support	12
4XB7B04552	CA3Q	ThinkSystem 2.5" PM9D3a 30.72TB Read Intensive NVMe PCIe 5.0 x4 HS SSD	Not TCE	Support	12
4XB7A93122	C0ZV	ThinkSystem 2.5" U.2 VA 1.92TB Read Intensive NVMe PCIe 5.0 x4 HS SSD	TCE	Support	12
4XB7A93123	C0ZU	ThinkSystem 2.5" U.2 VA 3.84TB Read Intensive NVMe PCIe 5.0 x4 HS SSD	TCE	Support	12
4XB7A93124	C0ZT	ThinkSystem 2.5" U.2 VA 7.68TB Read Intensive NVMe PCIe 5.0 x4 HS SSD	TCE	Support	12
4XB7A93125	C0ZS	ThinkSystem 2.5" U.2 VA 15.36TB Read Intensive NVMe PCIe 5.0 x4 HS SSD	Not TCE	Support	12
4XB7A93126	C1W7	ThinkSystem 2.5" U.2 VA 30.72TB Read Intensive NVMe PCIe 5.0 x4 HS SSD	Not TCE	Support	12
2.5-inch SSDs - U.3 PCIe 5.0 NVMe - Read Intensive/Entry (<3 DWPD)					
4XB7A82366	BTPZ	ThinkSystem 2.5" U.3 PM1743 1.92TB Read Intensive NVMe PCIe 5.0 x4 HS SSD	Not TCE	Support	12
4XB7A82367	BTQ0	ThinkSystem 2.5" U.3 PM1743 3.84TB Read Intensive NVMe PCIe 5.0 x4 HS SSD	TCE	Support	12
4XB7A82368	BTQ1	ThinkSystem 2.5" U.3 PM1743 7.68TB Read Intensive NVMe PCIe 5.0 x4 HS SSD	Not TCE	Support	12
4XB7A82369	BTQ2	ThinkSystem 2.5" U.3 PM1743 15.36TB Read Intensive NVMe PCIe 5.0 x4 HS SSD	Not TCE	Support	12

Table 50. 2.5-inch hot-swap PCIe 4.0 NVMe SSDs

Part number	Feature code	Description	Top Choice Express	SED support	Max Qty
2.5-inch SSDs - U.2 PCIe 4.0 NVMe - Mixed Use/Mainstream (3-5 DDPD)					
4XB7B11682	CCZE	ThinkSystem 2.5" U.2 VA 800GB Mixed Use NVMe PCIe 4.0 x4 HS SSD	Not TCE	Support	12
4XB7A93896	C18J	ThinkSystem 2.5" U.2 VA 1.6TB Mixed Use NVMe PCIe 4.0 x4 HS SSD	TCE	Support	12
4XB7A93897	C18H	ThinkSystem 2.5" U.2 VA 3.2TB Mixed Use NVMe PCIe 4.0 x4 HS SSD	TCE	Support	12
4XB7A93898	C18G	ThinkSystem 2.5" U.2 VA 6.4TB Mixed Use NVMe PCIe 4.0 x4 HS SSD	Not TCE	Support	12
4XB7A93899	C18F	ThinkSystem 2.5" U.2 VA 12.8TB Mixed Use NVMe PCIe 4.0 x4 HS SSD	Not TCE	Support	12
2.5-inch SSDs - U.3 PCIe 4.0 NVMe - Mixed Use/Mainstream (3-5 DDPD)					
4XB7A95054	C2BG	ThinkSystem 2.5" U.3 7500 MAX 800GB Mixed Use NVMe PCIe 4.0 x4 HS SSD	TCE	Support	12
4XB7A95055	C2BV	ThinkSystem 2.5" U.3 7500 MAX 1.6TB Mixed Use NVMe PCIe 4.0 x4 HS SSD	TCE ⓘ	Support	12
4XB7A95056	C2BW	ThinkSystem 2.5" U.3 7500 MAX 3.2TB Mixed Use NVMe PCIe 4.0 x4 HS SSD	TCE ⓘ	Support	12
4XB7A95057	C2BF	ThinkSystem 2.5" U.3 7500 MAX 6.4TB Mixed Use NVMe PCIe 4.0 x4 HS SSD	TCE ⓘ	Support	12
4XB7A95058	C2BX	ThinkSystem 2.5" U.3 7500 MAX 12.8TB Mixed Use NVMe PCIe 4.0 x4 HS SSD	Not TCE	Support	12
2.5-inch SSDs - U.2 PCIe 4.0 NVMe - Read Intensive/Entry (<3 DDPD)					
4XB7A95047	C2BL	ThinkSystem 2.5" U.2 P5336 7.68TB Read Intensive NVMe PCIe 4.0 x4 HS SSD	Not TCE	Support	12
4XB7A95048	C2BK	ThinkSystem 2.5" U.2 P5336 15.36TB Read Intensive NVMe PCIe 4.0 x4 HS SSD	Not TCE	Support	12
4XB7B11683	CCZF	ThinkSystem 2.5" U.2 VA 960GB Read Intensive NVMe PCIe 4.0 x4 HS SSD	Not TCE	Support	12
4XB7A93892	C18N	ThinkSystem 2.5" U.2 VA 1.92TB Read Intensive NVMe PCIe 4.0 x4 HS SSD	TCE	Support	12
4XB7A93893	C18M	ThinkSystem 2.5" U.2 VA 3.84TB Read Intensive NVMe PCIe 4.0 x4 HS SSD	TCE	Support	12
4XB7A93894	C18L	ThinkSystem 2.5" U.2 VA 7.68TB Read Intensive NVMe PCIe 4.0 x4 HS SSD	TCE	Support	12
4XB7A93895	C18K	ThinkSystem 2.5" U.2 VA 15.36TB Read Intensive NVMe PCIe 4.0 x4 HS SSD	Not TCE	Support	12
2.5-inch SSDs - U.3 PCIe 4.0 NVMe - Read Intensive/Entry (<3 DDPD)					
4XB7A95049	C2BY	ThinkSystem 2.5" U.3 7500 PRO 960GB Read Intensive NVMe PCIe 4.0 x4 HS SSD	TCE	Support	12
4XB7A95050	C2BR	ThinkSystem 2.5" U.3 7500 PRO 1.92TB Read Intensive NVMe PCIe 4.0 x4 HS SSD	TCE	Support	12
4XB7A95051	C2BS	ThinkSystem 2.5" U.3 7500 PRO 3.84TB Read Intensive NVMe PCIe 4.0 x4 HS SSD	TCE	Support	12

Part number	Feature code	Description	Top Choice Express	SED support	Max Qty
4XB7A95052	C2BT	ThinkSystem 2.5" U.3 7500 PRO 7.68TB Read Intensive NVMe PCIe 4.0 x4 HS SSD	TCE ⓘ	Support	12
4XB7A95053	C2BU	ThinkSystem 2.5" U.3 7500 PRO 15.36TB Read Intensive NVMe PCIe 4.0 x4 HS SSD	Not TCE	Support	12
4XB7A91176	BZC1	ThinkSystem 2.5" U.3 6500 ION 30.72TB Read Intensive NVMe PCIe 4.0 x4 HS SSD	Not TCE	Support	12
4XB7A81952	BPKY	ThinkSystem 2.5" U.3 PM1733a 3.84TB Read Intensive NVMe PCIe 4.0 x4 HS SSD	Not TCE	Support	12
4XB7A81954	BPL0	ThinkSystem 2.5" U.3 PM1733a 15.36TB Read Intensive NVMe PCIe 4.0 x4 HS SSD	Not TCE	Support	12

Table 51. 7mm 2.5-inch hot-swap 6 Gb SATA SSDs

Part number	Feature code	Description	Top Choice Express	SED support	Max Qty
7mm 2.5-inch hot-swap SSDs - 6 Gb SATA - Read Intensive/Entry (<3 DWPD)					
4XB7A82265	BQ1V	ThinkSystem 7mm 5400 PRO 480GB Read Intensive SATA 6Gb HS SSD	Not TCE	Support	2
4XB7A82266	BQ1W	ThinkSystem 7mm 5400 PRO 960GB Read Intensive SATA 6Gb HS SSD	Not TCE	Support	2
4XB7A17107	BK7A	ThinkSystem 7mm S4520 480GB Read Intensive SATA 6Gb HS SSD	Not TCE	No	2
4XB7A17108	BK7B	ThinkSystem 7mm S4520 960GB Read Intensive SATA 6Gb HS SSD	Not TCE	No	2

Table 52. 7mm 2.5-inch hot-swap PCIe 4.0 NVMe SSDs

Part number	Feature code	Description	Top Choice Express	SED support	Max Qty
7mm 2.5-inch hot-swap SSDs - PCIe 4.0 NVMe - Read Intensive/Entry (<3 DWPD)					
4XB7A90097	BXMM	ThinkSystem 7mm U.2 PM9A3 1.92TB Read Intensive NVMe PCIe 4.0 x4 HS SSD	Not TCE	Support	2
4XB7A90098	BXML	ThinkSystem 7mm U.2 PM9A3 3.84TB Read Intensive NVMe PCIe 4.0 x4 HS SSD	Not TCE	Support	2

Table 53. E1.S EDSFF hot-swap PCIe 4.0 NVMe SSDs

Part number	Feature code	Description	Top Choice Express	SED support	Max Qty
E1.S hot-swap SSDs - PCIe 4.0 NVMe - Read Intensive/Entry (<3 DWPD)					
4XB7A13998	BP3L	ThinkSystem E1.S 5.9mm 7450 PRO 3.84TB Read Intensive NVMe PCIe 4.0 x4 HS SSD	Not TCE	Support	16
4XB7A80499	BPKW	ThinkSystem E1.S 5.9mm 7450 PRO 7.68TB Read Intensive NVMe PCIe 4.0 x4 HS SSD	Not TCE	Support	16

Table 54. 3.5-inch hot-swap 12 Gb SAS HDDs

Part number	Feature code	Description	Top Choice Express	SED support	Max Qty
3.5-inch hot-swap HDDs - 12 Gb NL SAS					
4XB7B01233	C5WY	ThinkSystem 3.5" 2TB 7.2K SAS 12Gb Hot Swap 512e HDD v2	Not TCE	Support	4
7XB7A00042	AUU5	ThinkSystem 3.5" 2TB 7.2K SAS 12Gb Hot Swap 512n HDD	Not TCE	No	4
4XB7B01235	C5X9	ThinkSystem 3.5" 4TB 7.2K SAS 12Gb Hot Swap 512e HDD v2	Not TCE	Support	4
7XB7A00043	AUU6	ThinkSystem 3.5" 4TB 7.2K SAS 12Gb Hot Swap 512n HDD	Not TCE	No	4
4XB7B01237	C5XB	ThinkSystem 3.5" 6TB 7.2K SAS 12Gb Hot Swap 512e HDD v2	Not TCE	Support	4
4XB7B01239	C5XD	ThinkSystem 3.5" 8TB 7.2K SAS 12Gb Hot Swap 512e HDD v2	Not TCE	Support	4
7XB7A00045	B0YR	ThinkSystem 3.5" 8TB 7.2K SAS 12Gb Hot Swap 512e HDD	TCE	No	4
4XB7B01241	C5XF	ThinkSystem 3.5" 10TB 7.2K SAS 12Gb Hot Swap 512e HDD v2	Not TCE	Support	4
7XB7A00046	AUUG	ThinkSystem 3.5" 10TB 7.2K SAS 12Gb Hot Swap 512e HDD	Not TCE	No	4
7XB7A00067	B117	ThinkSystem 3.5" 12TB 7.2K SAS 12Gb Hot Swap 512e HDD	Not TCE	No	4
4XB7A93788	C4DA	ThinkSystem 3.5" 12TB 7.2K SAS 12Gb Hot Swap 512e HDD v2	Not TCE	Support	4
4XB7A13911	B7EZ	ThinkSystem 3.5" 16TB 7.2K SAS 12Gb Hot Swap 512e HDD	Not TCE	No	4
4XB7A93786	C4D8	ThinkSystem 3.5" 16TB 7.2K SAS 12Gb Hot Swap 512e HDD v2	Not TCE	Support	4
4XB7A38266	BCFP	ThinkSystem 3.5" 18TB 7.2K SAS 12Gb Hot Swap 512e HDD	Not TCE	No	4
4XB7A80353	BPKU	ThinkSystem 3.5" 20TB 7.2K SAS 12Gb Hot Swap 512e HDD	Not TCE	No	4
4XB7A93784	C4D6	ThinkSystem 3.5" 20TB 7.2K SAS 12Gb Hot Swap 512e HDD v2	Not TCE	Support	4
4XB7A83766	BTR7	ThinkSystem 3.5" 22TB 7.2K SAS 12Gb Hot Swap 512e HDD	Not TCE	Support	4
4XB7A93007	C2BH	ThinkSystem 3.5" 24TB 7.2K SAS 12Gb Hot Swap 512e HDD	Not TCE	Support	4
3.5-inch hot-swap SED HDDs - 12 Gb NL SAS					
7XB7A00066	B0YQ	ThinkSystem 3.5" 8TB 7.2K SAS 12Gb Hot Swap 512e HDD FIPS	Not TCE	Support	4

Table 55. 3.5-inch hot-swap 6 Gb SATA HDDs

Part number	Feature code	Description	Top Choice Express	SED support	Max Qty
3.5-inch hot-swap HDDs - 6 Gb NL SATA					
4XB7A97045	C5X6	ThinkSystem 3.5" 1TB 7.2K SATA 6Gb Hot Swap 512n HDD v2	Not TCE	Support	4
4XB7B01234	C5X8	ThinkSystem 3.5" 2TB 7.2K SATA 6Gb Hot Swap 512e HDD v2	TCE	Support	4
7XB7A00050	AUUD	ThinkSystem 3.5" 2TB 7.2K SATA 6Gb Hot Swap 512n HDD	Not TCE	No	4
4XB7B01236	C5XA	ThinkSystem 3.5" 4TB 7.2K SATA 6Gb Hot Swap 512e HDD v2	Not TCE	Support	4

Part number	Feature code	Description	Top Choice Express	SED support	Max Qty
7XB7A00051	AUU8	ThinkSystem 3.5" 4TB 7.2K SATA 6Gb Hot Swap 512n HDD	TCE	No	4
4XB7B01238	C5XC	ThinkSystem 3.5" 6TB 7.2K SATA 6Gb Hot Swap 512e HDD v2	Not TCE	Support	4
7XB7A00052	AUUA	ThinkSystem 3.5" 6TB 7.2K SATA 6Gb Hot Swap 512e HDD	Not TCE	No	4
4XB7B01240	C5XE	ThinkSystem 3.5" 8TB 7.2K SATA 6Gb Hot Swap 512e HDD v2	Not TCE	Support	4
7XB7A00053	AUU9	ThinkSystem 3.5" 8TB 7.2K SATA 6Gb Hot Swap 512e HDD	TCE	No	4
4XB7B01242	C5X7	ThinkSystem 3.5" 10TB 7.2K SATA 6Gb Hot Swap 512e HDD v2	Not TCE	Support	4
7XB7A00054	AUUB	ThinkSystem 3.5" 10TB 7.2K SATA 6Gb Hot Swap 512e HDD	Not TCE	No	4
7XB7A00068	B118	ThinkSystem 3.5" 12TB 7.2K SATA 6Gb Hot Swap 512e HDD	Not TCE	No	4
4XB7A93787	C4D9	ThinkSystem 3.5" 12TB 7.2K SATA 6Gb Hot Swap 512e HDD v2	Not TCE	Support	4
4XB7A13907	B497	ThinkSystem 3.5" 14TB 7.2K SATA 6Gb Hot Swap 512e HDD	Not TCE	No	4
4XB7A13914	B7F0	ThinkSystem 3.5" 16TB 7.2K SATA 6Gb Hot Swap 512e HDD	Not TCE	No	4
4XB7A93785	C4D7	ThinkSystem 3.5" 16TB 7.2K SATA 6Gb Hot Swap 512e HDD v2	Not TCE	Support	4
4XB7A38130	BCFH	ThinkSystem 3.5" 18TB 7.2K SATA 6Gb Hot Swap 512e HDD	Not TCE	No	4
4XB7A80354	BPKV	ThinkSystem 3.5" 20TB 7.2K SATA 6Gb Hot Swap 512e HDD	Not TCE	No	4
4XB7A93783	C4D5	ThinkSystem 3.5" 20TB 7.2K SATA 6Gb Hot Swap 512e HDD v2	Not TCE	Support	4
4XB7A83765	BTR8	ThinkSystem 3.5" 22TB 7.2K SATA 6Gb Hot Swap 512e HDD	Not TCE	Support	4
4XB7A93008	C2BJ	ThinkSystem 3.5" 24TB 7.2K SATA 6Gb Hot Swap 512e HDD	Not TCE	Support	4

Table 56. 3.5-inch hot-swap 24 Gb SAS SSDs

Part number	Feature code	Description	Top Choice Express	SED support	Max Qty
3.5-inch hot-swap SSDs - 24 Gb SAS - Mixed Use/Mainstream (3-5 DWPD)					
4XB7B07616	CABM	ThinkSystem 3.5" VA 800GB Mixed Use SAS 24Gb HS SSD	Not TCE	Support	4
4XB7B07617	CABP	ThinkSystem 3.5" VA 1.6TB Mixed Use SAS 24Gb HS SSD	Not TCE	Support	4
4XB7B07618	CABN	ThinkSystem 3.5" VA 3.2TB Mixed Use SAS 24Gb HS SSD	TCE	Support	4
4XB7B07619	CAC8	ThinkSystem 3.5" VA 6.4TB Mixed Use SAS 24Gb HS SSD	Not TCE	Support	4
3.5-inch hot-swap SSDs - 24 Gb SAS - Read Intensive/Entry/Capacity (<3 DWPD)					
4XB7B07606	CAFQ	ThinkSystem 3.5" VA 960GB Read Intensive SAS 24Gb HS SSD	Not TCE	Support	4
4XB7B07607	CAFN	ThinkSystem 3.5" VA 1.92TB Read Intensive SAS 24Gb HS SSD	Not TCE	Support	4
4XB7B07608	CAFP	ThinkSystem 3.5" VA 3.84TB Read Intensive SAS 24Gb HS SSD	Not TCE	Support	4
4XB7B07609	CAFM	ThinkSystem 3.5" VA 7.68TB Read Intensive SAS 24Gb HS SSD	Not TCE	Support	4
4XB7B07610	CAFR	ThinkSystem 3.5" VA 15.36TB Read Intensive SAS 24Gb HS SSD	Not TCE	Support	4

Table 58. 3.5-inch hot-swap 6 Gb SATA SSDs

Part number	Feature code	Description	Top Choice Express	SED support	Max Qty
3.5-inch hot-swap SSDs - 6 Gb SATA - Mixed Use/Mainstream (3-5 DDPD)					
4XB7B11652	CCZK	ThinkSystem 3.5" VA 480GB Mixed Use SATA 6Gb HS SSD SED	Not TCE	Support	4
4XB7B11653	CCZJ	ThinkSystem 3.5" VA 960GB Mixed Use SATA 6Gb HS SSD SED	Not TCE	Support	4
4XB7B11654	CCZH	ThinkSystem 3.5" VA 1.92TB Mixed Use SATA 6Gb HS SSD SED	Not TCE	Support	4
4XB7B11655	CCZG	ThinkSystem 3.5" VA 3.84TB Mixed Use SATA 6Gb HS SSD SED	Not TCE	Support	4
4XB7A90888	BYM3	ThinkSystem 3.5" VA 480GB Mixed Use SATA 6Gb HS SSD v2	TCE	No	4
4XB7A90889	BYM7	ThinkSystem 3.5" VA 960GB Mixed Use SATA 6Gb HS SSD v2	Not TCE	No	4
4XB7A90890	BYM8	ThinkSystem 3.5" VA 1.92TB Mixed Use SATA 6Gb HS SSD v2	Not TCE	No	4
4XB7A90891	BYLX	ThinkSystem 3.5" VA 3.84TB Mixed Use SATA 6Gb HS SSD v2	Not TCE	No	4
3.5-inch hot-swap SSDs - 6 Gb SATA - Read Intensive/Entry (<3 DDPD)					
4XB7B11648	CCZP	ThinkSystem 3.5" VA 480GB Read Intensive SATA 6Gb HS SSD SED	Not TCE	Support	4
4XB7B11649	CCZN	ThinkSystem 3.5" VA 960GB Read Intensive SATA 6Gb HS SSD SED	Not TCE	Support	4
4XB7B11650	CCZM	ThinkSystem 3.5" VA 1.92TB Read Intensive SATA 6Gb HS SSD SED	Not TCE	Support	4
4XB7B11651	CCZL	ThinkSystem 3.5" VA 3.84TB Read Intensive SATA 6Gb HS SSD SED	Not TCE	Support	4
4XB7A90879	BYLJ	ThinkSystem 3.5" VA 480GB Read Intensive SATA 6Gb HS SSD v2	TCE	No	4
4XB7A90880	BYLY	ThinkSystem 3.5" VA 960GB Read Intensive SATA 6Gb HS SSD v2	TCE	No	4
4XB7A90881	BYLZ	ThinkSystem 3.5" VA 1.92TB Read Intensive SATA 6Gb HS SSD v2	Not TCE	No	4
4XB7A90882	BYM0	ThinkSystem 3.5" VA 3.84TB Read Intensive SATA 6Gb HS SSD v2	Not TCE	No	4
4XB7A90883	BYM1	ThinkSystem 3.5" VA 7.68TB Read Intensive SATA 6Gb HS SSD v2	Not TCE	No	4

Table 59. 3.5-inch hot-swap PCIe 5.0 NVMe SSDs

Part number	Feature code	Description	Top Choice Express	SED support	Max Qty
3.5-inch SSDs - U.2 PCIe 5.0 NVMe - Read Intensive/Entry (<3 DDPD)					
4XB7B13984	CFA6	ThinkSystem 3.5" U.2 VA 1.92TB Read Intensive NVMe PCIe 5.0 x4 HS SSD	Not TCE	Support	4

Part number	Feature code	Description	Top Choice Express	SED support	Max Qty
4XB7B13985	CFA5	ThinkSystem 3.5" U.2 VA 3.84TB Read Intensive NVMe PCIe 5.0 x4 HS SSD	Not TCE	Support	4
4XB7B13986	CFA4	ThinkSystem 3.5" U.2 VA 7.68TB Read Intensive NVMe PCIe 5.0 x4 HS SSD	Not TCE	Support	4
4XB7B13987	CFA3	ThinkSystem 3.5" U.2 VA 15.36TB Read Intensive NVMe PCIe 5.0 x4 HS SSD	Not TCE	Support	4

Table 60. 3.5-inch hot-swap PCIe 4.0 NVMe SSDs

Part number	Feature code	Description	Top Choice Express	SED support	Max Qty
3.5-inch SSDs - U.2 PCIe 4.0 NVMe - Mixed Use/Mainstream (3-5 DWPD)					
4XB7B01883	C6M6	ThinkSystem 3.5" U.2 Solidigm P5620 1.6TB Mixed Use NVMe PCIe 4.0 x4 HS SSD	Not TCE	Support	4
4XB7B01884	C6M7	ThinkSystem 3.5" U.2 Solidigm P5620 3.2TB Mixed Use NVMe PCIe 4.0 x4 HS SSD	Not TCE	Support	4
4XB7B01885	C6M8	ThinkSystem 3.5" U.2 Solidigm P5620 6.4TB Mixed Use NVMe PCIe 4.0 x4 HS SSD	Not TCE	Support	4
3.5-inch SSDs - U.2 PCIe 4.0 NVMe - Read Intensive/Entry (<3 DWPD)					
4XB7B01871	C6MD	ThinkSystem 3.5" U.2 Solidigm P5520 1.92TB Read Intensive NVMe PCIe 4.0 x4 HS SSD	Not TCE	Support	4
4XB7B01872	C6ME	ThinkSystem 3.5" U.2 Solidigm P5520 3.84TB Read Intensive NVMe PCIe 4.0 x4 HS SSD	Not TCE	Support	4
4XB7B01873	C6MF	ThinkSystem 3.5" U.2 Solidigm P5520 7.68TB Read Intensive NVMe PCIe 4.0 x4 HS SSD	Not TCE	Support	4

Table 61. M.2 SATA drives

Part number	Feature code	Description	Top Choice Express	SED support	Max Qty
M.2 SSDs - 6 Gb SATA - Read Intensive/Entry (<3 DWPD)					
4XB7B07588	CABU	ThinkSystem M.2 VA 480GB Read Intensive SATA 6Gb NHS SSD	Not TCE	Support	2
4XB7B07589	CACA	ThinkSystem M.2 VA 960GB Read Intensive SATA 6Gb NHS SSD	TCE	Support	2

Table 62. M.2 PCIe 4.0 NVMe drives

Part number	Feature code	Description	Top Choice Express	SED support	Max Qty
M.2 SSDs - PCIe 4.0 NVMe - Read Intensive/Entry (<3 DWPD)					
4XB7B09650	CBSZ	ThinkSystem M.2 VA 480GB Read Intensive NVMe PCIe 4.0 x4 NHS SSD	Not TCE	Support	2
4XB7B09651	CBT0	ThinkSystem M.2 VA 960GB Read Intensive NVMe PCIe 4.0 x4 NHS SSD	TCE	Support	2

Part number	Feature code	Description	Top Choice Express	SED support	Max Qty
4XB7A90102	BXMH	ThinkSystem M.2 PM9A3 960GB Read Intensive NVMe PCIe 4.0 x4 NHS SSD	Not TCE	Support	2

USB flash drive

For general portable storage needs, the server also supports the USB flash drive option that is listed in the following table.

Table 63. USB memory key

Part number	Feature	Description	Top Choice Express
4X77A77065	BNWN	ThinkSystem USB 32GB USB 3.0 Flash Drive	Not TCE

Internal backup units

The SR645 V3 does not support any internal backup units, such as tape drives or RDX drives. External backup units are available as described in the [External backup units](#) section.

Optical drives

The server supports the external USB optical drive listed in the following table.

Table 64. External optical drive

Part number	Feature code	Description	Top Choice Express
7XA7A05926	AVV8	ThinkSystem External USB DVD RW Optical Disk Drive	TCE

The drive is based on the Lenovo Slim DVD Burner DB65 drive and supports the following formats: DVD-RAM, DVD-RW, DVD+RW, DVD+R, DVD-R, DVD-ROM, DVD-R DL, CD-RW, CD-R, CD-ROM.

I/O expansion

The SR645 V3 supports a total of up to 5x PCIe slots, 3x at the rear and 2x at the front, plus 1x OCP 3.0 SFF slot for networking. The OCP slot can be either at the front or at the rear (but not both). Slot availability is based on riser selection and drive bays configured. The use of slot 3 and the front slots require that both processors be installed.

Internal (CFF) RAID adapter/HBA: For configurations with 2.5-inch front drive bays, an internal RAID adapter or HBA (CFF, custom form factor) can be installed in a dedicated space and cabled to a PCIe 4.0 x8 connector, thereby freeing up a slot for other purposes.

Topics in this section:

- [Rear slots](#)
- [Front slots](#)
- [Serial port](#)
- [OCP slot filler](#)

Rear slots

The following figure shows the locations of the rear-accessible slots for each configuration selection. The OCP slot is located below the PCIe slots.

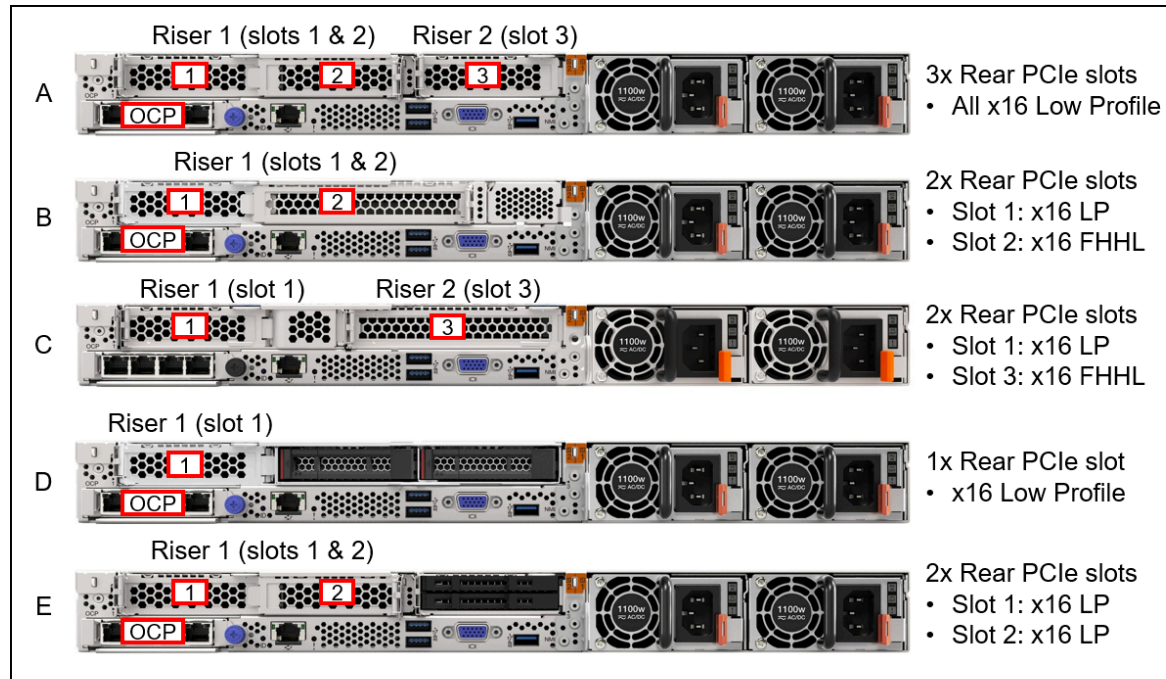

Figure 16. SR645 V3 rear slot configurations

The rear-accessible slots and riser cards are as follows:

- Riser 1: Slots 1 & 2 (connect to CPU 1)
 - Slot 1: Low Profile, PCIe x16
 - Slot 2: Low Profile or FHHL, PCIe x16 (only in configuration A, B, and E in the above figure)
- Riser 2: Slot 3 (connects to CPU 2)
 - Slot 3: Low Profile or FHHL, PCIe x16 (only in configuration A and C)

The PCIe slots can be configured as PCIe 5.0 (Gen 5) or PCIe 4.0 (Gen 4) depending on your workload requirements, however slot 2 will always be PCIe 4.0.

The following table lists the available riser cards for the rear slots. The table includes a Top Choice Express column; for CTO orders, select a TCE component for faster delivery. See the [Top Choice](#) section for more information.

Table 65. Riser cards for rear slots

Feature code	Description	Top Choice Express
Rear slots - Riser 1 - Gen 5		
BLKB	ThinkSystem V3 1U x16/x16 BF PCIe Gen5 Riser1	TCE
BLK7	ThinkSystem SR635 V3/SR645 V3 x16 PCIe Gen5 Riser 1	Not TCE
BP39	ThinkSystem SR630 V3/SR645 V3 x16/E PCIe Gen5 Riser1 BF	TCE
Rear slots - Riser 2 - Gen 5		
BLKA	ThinkSystem V3 1U x16 PCIe Gen5 Riser2	Not TCE
BVHN	ThinkSystem V3 1U x16 PCIe Gen5 Riser2 v2	Not TCE
Rear slots - Riser 1 - Gen 4		

Feature code	Description	Top Choice Express
BLKF	ThinkSystem V3 1U x16/x16 BF PCIe Gen4 Riser1	TCE
BLKE	ThinkSystem V3 1U x16 Riser1 PCIe Gen4 with Rear drive	Not TCE
Rear slots - Riser 2 - Gen 4		
BLKG	ThinkSystem V3 1U x16 PCIe Gen4 Riser2	TCE

The following table lists the ordering information for the rear PCIe slots in the SR645 V3. The Cfg column matches the slot configurations shown in the preceding figure. The table is divided up into configurations with Gen5 slots with Gen4, and configurations with only Gen4 slots. Ordering information is as follows:

- For CTO orders, order the feature codes listed for the configuration, both riser and cage feature codes (2 or 4 feature codes, depending on the configuration)
- For field upgrades, order the part numbers listed for the configuration (1 or 2 part numbers, depending on the configuration). The part numbers include both the risers and cages needed for that configuration.

No slots: It is also possible to build a configuration without any slots, in which case slot fillers will be derived in the configurator. Slots can be added later as field upgrades using option part numbers in the table below.

Table 66. Riser slot ordering information

Cfg	Part number	Features		Description	Slot configuration* (Green = Gen5, Blue = Gen4)			Purpose
		Riser	Cage		Slot 1	Slot 2	Slot 3	
Rear slots - Gen 5					Slot 1	Slot 2	Slot 3	
A	4XH7A83845	BLKB	BLK9	ThinkSystem V3 1U x16/x16 PCIe Gen5 Riser 1 LP+LP	Gen5 x16 LP	Gen4 x16 LP		3x Low Profile slots (2x Gen5, 1x Gen4)
	4XH7A83843 or 4XH7A88518	BLKA or BVHN	BLK6	ThinkSystem V3 1U x16 PCIe Gen5 Riser 2 or ThinkSystem V3 1U x16 PCIe G5 Riser 2 v2			Gen5 x16 LP	
A	4XH7A83842	BLK7*	BLK9	ThinkSystem SR635 V3/SR645 V3 x16 PCIe Gen5 Riser 1 Option Kit	Gen5 x16 LP	No slot		2x Low Profile slots (1x Gen5, 1x Gen4). Supports 1x NVIDIA L4 GPU.
	4XH7A83849	BLKG	BLK6	ThinkSystem V3 1U x16 PCIe Gen4 Riser 2 Option Kit			Gen4 x16 LP	
B	4XH7A83844	BLKB	BLK8	ThinkSystem V3 1U x16/x16 PCIe Gen5 Riser 1 LP+FH	Gen5 x16 LP	Gen4 x16 FH	No slot	2x slots, 1xLP+1xFH, both to CPU 1 (1x Gen5, 1x Gen4)
C	4XH7A85014 or 4XH7A86136*	BP39 or BLK7*	BP3A	ThinkSystem V3 1U x16 PCIe Gen5 Riser 1 with Full Height Slot 3 or ThinkSystem SR635 V3/SR645 V3 x16 PCIe Gen5 Riser 1 LP Option Kit	Gen5 x16 LP	No slot		2x slots: 1LP + 1FH, one to each CPU (2x Gen5). Use BLK7+BLKA for 2x NVIDIA L4 GPU support.
	4XH7A83843 or 4XH7A88518	BLKA or BVHN	BLK6	ThinkSystem V3 1U x16 PCIe Gen5 Riser 2 or ThinkSystem V3 1U x16 PCIe G5 Riser 2 v2			Gen5 x16 FH	
D	4XH7A85013	BP39	BLK6	ThinkSystem V3 1U x16 PCIe Gen5 Riser 1 with Rear Drive	Gen5 x16 LP	Drive	Drive	Supports 2x 2.5-inch drives (1x Gen5 slot)
E	4XH7A83845	BLKB	BLK9	ThinkSystem V3 1U x16/x16 PCIe Gen5 Riser 1 LP+LP	Gen5 x16 LP	Gen4 x16 LP	Drives	Supports 2x 7mm drives (1x Gen5, 1x Gen4 slots)
E	4XH7A83842	BLK7*	BLK9	ThinkSystem SR635 V3/SR645 V3 x16 PCIe Gen5 Riser 1 Option Kit	Gen5 x16 LP	No slot	Drives	1x LP x16 Gen5 slot, supports 2x 7mm drives. Supports 1x NVIDIA L4 GPU.

Cfg	Part number	Features		Description	Slot configuration* (Green = Gen5, Blue = Gen4)			Purpose
		Riser	Cage		Slot 1	Slot 3	Slot 3	
Rear slots - Gen 4					Slot 1	Slot 3	Slot 3	
A	4XH7A83847	BLKF	BLK9	ThinkSystem V3 1U x16/x16 PCIe Gen4 Riser 1 LP+LP	Gen4 x16 LP	Gen4 x16 LP		3x Low Profile slots (2x Gen4)
	4XH7A83849	BLKG	BLK6	ThinkSystem V3 1U x16 PCIe Gen4 Riser 2 Option Kit			Gen4 x16 LP	
B	4XH7A83846	BLKF	BLK8	ThinkSystem V3 1U x16/x16 PCIe Gen4 Riser 1 LP+FH	Gen4 x16 LP	Gen4 x16 FH	No slot	2x slots, 1xLP+1xFH, both to CPU 1 (2x Gen4)
D	4XH7A83848	BLKE	BLK6	ThinkSystem V3 1U x16 PCIe Gen4 Riser 1 with Rear Drive	Gen4 x16 LP	Drive	Drive	Supports 2x 2.5-inch drives (1x Gen4 slot)
E	4XH7A83847	BLKF	BLK9	ThinkSystem V3 1U x16/x16 PCIe Gen4 Riser 1 LP+LP	Gen4 x16 LP	Gen4 x16 LP	Drives	Supports 2x 7mm drives (2x Gen4 slots)

* See configuration notes regarding Riser BLK7 below.

Configuration rules:

- For best performance, install PCIe 5.0 adapters in PCIe 5.0 (Gen5) slots
- Riser BLK7 (option 4XH7A86136) is currently only supported in configurations with 5th Gen AMD EPYC processors. Support for 4th Gen processors is planned for 1Q/2025

Front slots

As an addition or alternative to the rear slots, the SR645 V3 supports slots at the front of the server.

The following figure shows the locations of the front-accessible slots.

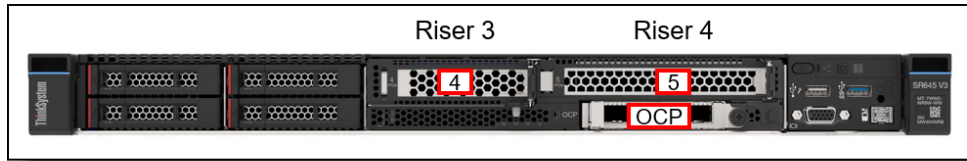

Figure 17. SR645 V3 front slots

The front-accessible slots and riser cards are as follows:

- Slot 4: Low Profile, PCIe Gen4 or Gen5, x8 (connects to CPU 2)
- Slot 5: FHHL, PCIe Gen4 or Gen5, x8 or x16 (connects to CPU 2)
- Slot 6: OCP 3.0 slot (PCIe Gen4 x16) (connects to CPU 1)

OCP slot: When front slots are configured, the rear OCP slot is disconnected and cannot be used.

Ordering information is listed in the following table. The table includes a Top Choice Express column; for CTO orders, select a TCE component for faster delivery. See the [Top Choice](#) section for more information.

Table 67. Front slots

Part number	Feature code	Description	Top Choice Express	PCIe
Slot 4 (Riser 3)				
CTO only	BUJY	ThinkSystem SR645 V3 Front x8 LP PCIe Gen4 Riser3	Not TCE	Gen4 x8

Part number	Feature code	Description	Top Choice Express	PCIe
CTO only	C255	ThinkSystem SR645 V3 Front x8 LP PCIe Gen5 Riser3	Not TCE	Gen5 x8
Slot 5 (Riser 4)				
CTO only	C256	ThinkSystem SR645 V3 Front x8 FHFL PCIe Gen5 Riser	Not TCE	Gen5 x8
CTO only	C1PQ	ThinkSystem V3 1U Front x16 FHFL PCIe Gen5 Riser	Not TCE	Gen5 x16
CTO only	BUJZ	ThinkSystem SR645 V3 Front x8 FHFL PCIe Gen4 Riser4	Not TCE	Gen4 x8
CTO only	BQ2G	ThinkSystem V3 1U Front x16 FHFL PCIe Gen4 Riser4	Not TCE	Gen4 x16

Support for front slots is based on the riser selected as well as the front drive bays selected, as listed in the following table.

Table 68. Front slot & drive bays - supported combinations

Backplane	Backplane description	Top Choice Express	Slot 4 (LP)	Slot 5 (FHHL)	Front OCP
BU19	2x 2.5-inch NVMe G5 drive bays	Not TCE	PCIe x8	PCIe x16	PCIe x16
BV8J	4x 2.5-inch NVMe G4 drive bays	Not TCE	PCIe x8	PCIe x16	PCIe x16
BT1Q	4x 2.5-inch NVMe G5 drive bays	Not TCE	PCIe x8	PCIe x8	PCIe x16
			Empty	PCIe x16	PCIe x16
BT1P	4x 2.5-inch AnyBay G5 drive bays	Not TCE	PCIe x8	PCIe x8	PCIe x16
			Empty	PCIe x16	PCIe x16

Configuration notes:

- Front slots are CTO only, not available as option part numbers for field upgrades
- The use of front slots requires base feature code BQ7M as described in the [Base feature codes](#) section
- Front slots can be used in conjunction with rear drive bays. See the table of configurations in the [Overview - 2.5-inch front bays with front slots](#) section for specifics.
- The front OCP slot is automatically derived by the configurator with riser 4 (slot 5)
- The front and rear OCP slots are mutually exclusive; when the front OCP slot is configured, the rear OCP slot is disconnected
- M.2 is not supported
- The use of the closed-loop liquid-cooled processor heatsink is not supported
- The use of the security bezel is not supported

Serial port

The SR645 V3 optionally supports a RS-232 serial port by adding a COM port bracket to either slot 2 or slot 3. Ordering information is shown in the following table.

No front slot support: The serial port is not supported in the front PCIe slots

Table 69. Serial port

Part number	Feature code	Description	Top Choice Express
4X97A82921	BMNJ	ThinkSystem V2/V3 1U COM Port Upgrade Kit	TCE

The bracket is shown in the following figure. The option part number includes both Low Profile and Full Height brackets.

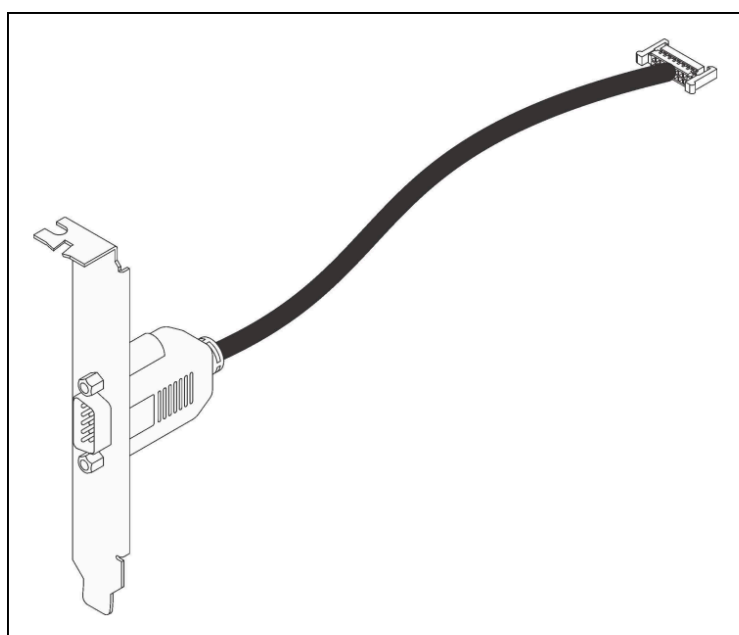

Figure 18. ThinkSystem V2/V3 1U COM Port Upgrade Kit

OCP slot filler

If customers or partners remove an OCP adapter from the server, we recommend that a slot cover (slot filler) be installed in its place to ensure proper airflow in the server. Ordering information is listed in the following table.

Tip: For CTO orders and preconfigured models, slot fillers are automatically installed in slots where an OCP adapter is not installed.

Table 70. OCP slot filler

Part number	Description
4XF7B06188	ThinkSystem OCP3 FILLER

Network adapters

The server has a dedicated OCP 3.0 SFF slot with PCIe 5.0 x16 host interface. See [Figure 3](#) for the location of the OCP slot.

The following table lists the supported OCP adapters. The table includes a Top Choice Express column; for CTO orders, select a TCE component for faster delivery. See the [Top Choice](#) section for more information.

One port can optionally be shared with the XCC management processor for Wake-on-LAN and NC-SI support. Only 1 OCP card can be installed in the server.

Table 71. Supported OCP adapters

Part number	Feature code	Description	Top Choice Express	Maximum supported	Windows 10/11 support
Gigabit Ethernet					
4XC7A08235	B5T1	ThinkSystem Broadcom 5719 1GbE RJ45 4-port OCP Ethernet Adapter	TCE	1	Supported
4XC7A88428	BW97	ThinkSystem Intel I350 1GbE RJ45 4-Port OCP Ethernet Adapter V2	TCE	1	Supported
4XC7A08277	B93E	ThinkSystem Intel I350 1GbE RJ45 4-port OCP Ethernet Adapter	Not TCE	1	Supported
10 Gb Ethernet - 10GBASE-T					
4XC7A95696	C4GB	ThinkSystem Broadcom 57412 10GBase-T 4-Port OCP Ethernet Adapter	TCE	1*	Supported
4XC7A08236	B5ST	ThinkSystem Broadcom 57416 10GBASE-T 2-port OCP Ethernet Adapter	TCE	1	Supported
4XC7A08278	BCD5	ThinkSystem Intel X710-T2L 10GBASE-T 2-port OCP Ethernet Adapter	TCE ⓘ	1	Supported
4XC7A80268	BPPY	ThinkSystem Intel X710-T4L 10GBase-T 4-Port OCP Ethernet Adapter	TCE	1	Supported
25 Gb Ethernet					
4XC7A08237	BN2T	ThinkSystem Broadcom 57414 10/25GbE SFP28 2-Port OCP Ethernet Adapter	TCE	1	Supported
4XC7A80567	BPPW	ThinkSystem Broadcom 57504 10/25GbE SFP28 4-Port OCP Ethernet Adapter	TCE	1	Supported
4XC7A08294	BCD4	ThinkSystem Intel E810-DA2 10/25GbE SFP28 2-Port OCP Ethernet Adapter	TCE	1	Supported
4XC7A80269	BP8L	ThinkSystem Intel E810-DA4 10/25GbE SFP28 4-Port OCP Ethernet Adapter	TCE	1	Supported
4XC7A62582	BE4T	ThinkSystem Mellanox ConnectX-6 Lx 10/25GbE SFP28 2-port OCP Ethernet Adapter	Not TCE	1	No
100 Gb Ethernet					
4XC7A08243	BPPX	ThinkSystem Broadcom 57508 100GbE QSFP56 2-Port OCP Ethernet Adapter	Not TCE	1	Supported

* ThinkSystem Broadcom 57412 10GBase-T 4-Port OCP Ethernet Adapter (4XC7A95696) is not supported when the OCP slot is located at the front of the server

The following table lists additional supported network adapters that can be installed in the regular PCIe slots. The table includes a Top Choice Express column; for CTO orders, select a TCE component for faster delivery. See the [Top Choice](#) section for more information.

Table 72. Supported PCIe Network Adapters

Part number	Feature code	Description	Top Choice Express	Form factor	Maximum quantity	Slots supported	Windows 10/11 support
Gigabit Ethernet							
7ZT7A00484	AUZV	ThinkSystem Broadcom 5719 1GbE RJ45 4-Port PCIe Ethernet Adapter	TCE	Low profile	3	1,2,3§	Supported
7ZT7A00535	AUZW	ThinkSystem I350-T4 PCIe 1Gb 4-Port RJ45 Ethernet Adapter	TCE	Low profile	3	1,2,3§	Supported
10 Gb Ethernet - 10GBASE-T							
4XC7A95697	C4GC	ThinkSystem Broadcom 57412 10GBase-T 4-Port PCIe Ethernet Adapter	TCE ⓘ	Low profile	5	1,2,3,4,5‡	Supported
7ZT7A00496	AUKP	ThinkSystem Broadcom 57416 10GBASE-T 2-Port PCIe Ethernet Adapter	TCE	Low profile	5	1,2,3,4,5	Supported
4XC7A80266	BNWL	ThinkSystem Intel X710-T2L 10GBase-T 2-Port PCIe Ethernet Adapter	TCE ⓘ	Low profile	5	1,2,3,4,5	Supported
4XC7A79699	BMXB	ThinkSystem Intel X710-T4L 10GBase-T 4-Port PCIe Ethernet Adapter	TCE ⓘ	Low profile	3	1,2,3	Supported
25 Gb Ethernet							
4XC7A84827	BUQK	ThinkSystem AMD X3522 10/25GbE DSFP28 2-Port PCIe Ethernet Adapter (Low Latency)	Not TCE	Low profile	4	1,2,3,5	No
4XC7A08238	BK1H	ThinkSystem Broadcom 57414 10/25GbE SFP28 2-port PCIe Ethernet Adapter	TCE	Low profile	5	1,2,3,4,5	Supported
4XC7A80566	BNWM	ThinkSystem Broadcom 57504 10/25GbE SFP28 4-port PCIe Ethernet Adapter	TCE	FHHL	1	2†	Supported
4XC7A08295	BCD6	ThinkSystem Intel E810-DA2 10/25GbE SFP28 2-Port PCIe Ethernet Adapter	TCE	Low profile	5	1,2,3,4,5	Supported
4XC7A80267	BP8M	ThinkSystem Intel E810-DA4 10/25GbE SFP28 4-Port PCIe Ethernet Adapter	TCE	FHHL	1	2,3†	Supported
4XC7A62580	BE4U	ThinkSystem Mellanox ConnectX-6 Lx 10/25GbE SFP28 2-port PCIe Ethernet Adapter	Not TCE	Low profile	5	1,2,3,4,5	No
4XC7A62581	BHE2	ThinkSystem Solarflare X2522-Plus 10/25GbE SFP28 2-Port PCIe Ethernet Adapter	Not TCE	Low profile	5	1,2,3,4,5	Supported
100 Gb Ethernet / HDR100 InfiniBand							
4XC7A08297	BK1J	ThinkSystem Broadcom 57508 100GbE QSFP56 2-Port PCIe 4 Ethernet Adapter	TCE ⓘ	Low profile	4	1,2,3,5	Supported
4XC7A08248	B8PP	ThinkSystem Mellanox ConnectX-6 Dx 100GbE QSFP56 2-port PCIe Ethernet Adapter	Not TCE	Low profile	4	1,2,3,5	No

Part number	Feature code	Description	Top Choice Express	Form factor	Maximum quantity	Slots supported	Windows 10/11 support
4C57A14177	B4R9	ThinkSystem Mellanox ConnectX-6 HDR100/100GbE QSFP56 1-port PCIe VPI Adapter	Not TCE	Low profile	4	1,2,3,5	No
200 Gb Ethernet / HDR InfiniBand / NDR200 InfiniBand							
4C57A15326	B4RC	ThinkSystem Mellanox ConnectX-6 HDR/200GbE QSFP56 1-port PCIe 4 VPI Adapter	Not TCE	Low profile	3	1,3,2	No
4XC7A81883	BQBN	ThinkSystem NVIDIA ConnectX-7 NDR200/200GbE QSFP112 2-port PCIe Gen5 x16 InfiniBand Adapter	Not TCE	Low profile	2	1,3	No
400 Gb Ethernet / NDR400 InfiniBand							
4XC7A95508	C51C	ThinkSystem NVIDIA ConnectX-7 NDR400 OSFP 1-port PCIe Gen5 VPI Adapter	Not TCE	Low profile	3	1,3,5	No
4XC7A80289	BQ1N	ThinkSystem NVIDIA ConnectX-7 NDR OSFP400 1-Port PCIe Gen5 x16 InfiniBand Adapter (InfiniBand only)	Not TCE	Low profile	3	1,3,5	No

† In the SR645 V3, this adapter requires a full-height bracket and must be installed in a full-height slot. The use of a low-profile bracket and slot is not supported.

§ Not supported installed in slot 1 of the LP+FH riser cage (configuration B in the [I/O expansion](#) section)

‡ Requires a PCIe Gen4 riser; Not supported in a PCIe Gen5 riser

For more information, including the transceivers and cables that each adapter supports, see the list of Lenovo Press Product Guides in the Networking adapters category:

<https://lenovopress.com/servers/options/ethernet>

Configuration rules:

- The following adapters are not supported installed into the LP+FH riser cage (configuration B in the [I/O expansion](#) section)
 - ThinkSystem Broadcom 5719 1GbE RJ45 4-Port PCIe Ethernet Adapter, 7ZT7A00484
 - ThinkSystem I350-T4 PCIe 1Gb 4-Port RJ45 Ethernet Adapter, 7ZT7A00535
 - ThinkSystem Broadcom 57454 10GBASE-T 4-port PCIe Ethernet Adapter, 4XC7A08245

Fibre Channel host bus adapters

The following table lists the Fibre Channel HBAs supported by the SR645 V3. The table includes a Top Choice Express column; for CTO orders, select a TCE component for faster delivery. See the [Top Choice](#) section for more information.

No Windows 10/11 support: None of the adapters listed in the table are supported with Windows 10 or Windows 11.

Table 73. Fibre Channel HBAs

Part number	Feature code	Description	Top Choice Express	Maximum quantity	Slots supported
64 Gb Fibre Channel					
4XC7A77485	BLC1	ThinkSystem Emulex LPe36002 64Gb 2-port PCIe Fibre Channel Adapter	TCE	5	1,2,3,4,5
32 Gb Fibre Channel					
4XC7A76498	BJ3G	ThinkSystem Emulex LPe35000 32Gb 1-port PCIe Fibre Channel Adapter v2	TCE	5	1,2,3,4,5
4XC7A76525	BJ3H	ThinkSystem Emulex LPe35002 32Gb 2-port PCIe Fibre Channel Adapter V2	TCE	5	1,2,3,4,5
4XC7A08279	BA1G	ThinkSystem QLogic QLE2770 32Gb 1-Port PCIe Fibre Channel Adapter	TCE ⓘ	5	1,2,3,4,5
4XC7A08276	BA1F	ThinkSystem QLogic QLE2772 32Gb 2-Port PCIe Fibre Channel Adapter	TCE	5	1,2,3,4,5
16 Gb Fibre Channel					
01CV830	ATZU	Emulex 16Gb Gen6 FC Single-port HBA	TCE	5	1,2,3,4,5
01CV840	ATZV	Emulex 16Gb Gen6 FC Dual-port HBA	TCE	5	1,2,3,4,5
01CV750	ATZB	QLogic 16Gb Enhanced Gen5 FC Single-port HBA	TCE	5	1,2,3,4,5
01CV760	ATZC	QLogic 16Gb Enhanced Gen5 FC Dual-port HBA	TCE	5	1,2,3,4,5

For more information, see the list of Lenovo Press Product Guides in the Host bus adapters category: <https://lenovopress.com/servers/options/hba>

SAS adapters for external storage

The following table lists SAS HBAs and RAID adapters supported by SR645 V3 server for use with external storage. The table includes a Top Choice Express column; for CTO orders, select a TCE component for faster delivery. See the [Top Choice](#) section for more information.

No Windows 10/11 support: None of the adapters listed in the table are supported with Windows 10 or Windows 11.

Table 74. Adapters for external storage

Part number	Feature code	Description	Top Choice Express	Maximum supported	Slots supported
SAS HBAs					
4Y37A78837	BNWK	ThinkSystem 440-8e SAS/SATA PCIe Gen4 12Gb HBA	Not TCE	5	1,2,3,4,5
4Y37A09724	B8P7	ThinkSystem 440-16e SAS/SATA PCIe Gen4 12Gb HBA	TCE	5	1,2,3,4,5
External RAID adapters					
4Y37A78836	BNWJ	ThinkSystem RAID 940-8e 4GB Flash PCIe Gen4 12Gb Adapter	TCE	1	1,2,3*

* See configuration rules below regarding supercap requirements

For a comparison of the functions of the supported storage adapters, see the ThinkSystem RAID Adapter and HBA Reference:

<https://lenovopress.lenovo.com/lp1288#sr645-v3-support=SR645%2520V3&internal-or-external-ports=External>

Configuration rules

- The RAID 940-8e uses a flash power module (supercap), and the SR645 V3 supports only 1 supercap depending on the configuration. See the [RAID flash power module \(supercap\) support](#) section for details. If a RAID 9XXX adapter is configured for connectivity to internal drive bays, then no RAID 940-8e are supported.

For more information, see the list of Lenovo Press Product Guides in the Host bus adapters and RAID adapters categories:

<https://lenovopress.com/servers/options/hba>

<https://lenovopress.com/servers/options/raid>

GPU adapters

The SR645 V3 supports the following graphics processing units (GPUs). The table includes a Top Choice Express column; for CTO orders, select a TCE component for faster delivery. See the [Top Choice](#) section for more information.

Table 75. Supported GPUs

Part number	Feature code	Description	Top Choice Express	Controlled GPU	TDP	Maximum supported	Slots supported	Windows 10/11 support
4X67A84824	BS2C	ThinkSystem NVIDIA L4 24GB PCIe Gen4 Passive GPU	Not TCE	Controlled	72W	4	1,3,4,5*	Supported

* See NVIDIA L4 configuration rules below

For information about these GPUs, see the ThinkSystem GPU Summary, available at: <https://lenovopress.com/lp0768-thinksystem-thinkagile-gpu-summary>

Configuration rules

The following configuration requirements must be met when installing GPUs:

- The table includes a Controlled GPU column. If a GPU is listed as Controlled, that means the GPU is not offered in certain markets, as determined by the US Government. If a GPU is listed as No, that means the GPU is not controlled and is available in all markets.
- GPUs can be configured in CTO orders as follows:
 - A Controlled GPU can only be configured using one of the Base CTO models designated with "for AI", such as 7D9CCTOAWW, as listed in the [Models](#) section.
 - A GPU that is not controlled can only be configured using one of the Base CTO models that is *not* named "for AI", such as 7D9CCTO1WW, as listed in the [Models](#) section.
- All GPUs installed must be identical
- Rear drive bays are not supported
- Flash storage adapters are not supported.
- Maximum ambient temperature is 30°C
- For details regarding supported combinations of front drive bays, processors, fans, and ambient temperature, see the Thermal Rules page of the User Guide: https://pubs.lenovo.com/sr645-v3/thermal_rules#server-models-with-gpus
- Performance fans are required and will be derived by the configurator for configure-to-order builds.
- When adding GPUs as field upgrades, you will be required to replace all Standard fans with Performance fans. See the [Cooling](#) section for ordering information.

Requirements for NVIDIA L4 GPUs:

- Two of the GPUs are installed in rear slots 1 & 3; the remaining GPU(s) are installed in front slots 5 & 4.
- If 3x NVIDIA L4 GPUs are to be configured, use the following riser cards (Rear slot Config C; see [I/O Expansion](#) section):
 - Slot 1: ThinkSystem SR645 V3/SR635 V3 x16 PCIe Gen5 Riser1, BLK7 (4XH7A86136)
 - Slot 3: ThinkSystem V3 1U x16 PCIe Gen5 Riser2, BLKA (4XH7A83843)
 - Slot 5: ThinkSystem V3 1U Front x16 FHFL PCIe Gen5 Riser, C1PQ (CTO only)
- If 4x NVIDIA L4 GPUs are to be configured, use the following riser cards (Rear slot Config C):
 - Slot 1: ThinkSystem SR645 V3/SR635 V3 x16 PCIe Gen5 Riser1, BLK7 (4XH7A86136)

- o Slot 3: ThinkSystem V3 1U x16 PCIe Gen5 Riser2, BLKA (4XH7A83843)
- o Slot 4: ThinkSystem SR645 V3 Front x8 LP PCIe Gen5 Riser3, C255 (CTO only)
- o Slot 5: Either of:
 - ThinkSystem V3 1U Front x16 FHFL PCIe Gen5 Riser, C1PQ (CTO only)
 - ThinkSystem SR645 V3 Front x8 FHFL PCIe Gen5 Riser, C256 (CTO only)

Cooling

The SR645 V3 server has up to eight 40 mm dual-rotor hot-swap variable-speed fans. Six fans are needed when one processor is installed and eight fans are required when two processors are installed. The server offers N+1 rotor redundancy. The server also has one additional fan integrated in each of the two power supplies.

Depending on the configuration, the server will need either Standard fans (21K RPM) or Performance fans (28K RPM)

Under the following conditions, Standard fans can be used:

- Processor with TDP \leq 240W
- No GPUs
- Front drive bays \leq 8x SAS/SATA drives
- Rear drive bays SAS/SATA, 7mm or 2.5-inch
- No NVMe drives, front or rear
- No 256GB 3DS RDIMMs
- None of the following network adapters:
 - o Any 100Gb, 200Gb or 400Gb adapter
 - o ThinkSystem Broadcom 57454 10GBASE-T 4-port OCP Ethernet Adapter

If any conditions are not met, Performance fans are required.

Ordering information for the fans is listed in the following table.

Table 76. Fan ordering information

Part number	Feature code	Description	Top Choice Express	Number required
4F17A14488	BH9N	ThinkSystem V3 1U Standard Fan Option Kit v2	TCE	1x CPU: 6 2x CPUs: 8
4F17A14487	BH9M	ThinkSystem V3 1U Performance Fan Option Kit v2	TCE	1x CPU: 6 2x CPUs: 8

Power supplies

The SR645 V3 supports up to two redundant hot-swap power supplies.

The power supply choices are listed in the following table. Both power supplies used in server must be identical.

Tip: When configuring a server in the DCSC configurator, power consumption is calculated precisely by interfacing with Lenovo Capacity Planner. You can therefore select the appropriate power supply for your configuration. However, do consider future upgrades that may require additional power needs.

Table 77. Power supply options

Part number	Feature code	Description	Top Choice Express	Maximum quantity	110V AC	220V AC	240V DC China only	-48V DC
AC input power - 80 PLUS Titanium efficiency								
4P57A82019	BR1X	ThinkSystem 750W 230V Titanium Hot-Swap Gen2 Power Supply v3	TCE	2	No	Yes	Yes	No
CTO only	C07V	ThinkSystem 750W 230V Titanium Hot-Swap Gen2 Power Supply v4	TCE	2	No	Yes	Yes	No
4P57A72666	BLKH	ThinkSystem 1100W 230V Titanium Hot-Swap Gen2 Power Supply	TCE	2	No	Yes	Yes	No
4P57A78359	BPK9	ThinkSystem 1800W 230V Titanium Hot-Swap Gen2 Power Supply	TCE	2	No	Yes	Yes	No
AC input power - 80 PLUS Platinum efficiency								
4P57A72670	BNFG	ThinkSystem 750W 230V/115V Platinum Hot-Swap Gen2 Power Supply v3	TCE	2	Yes	Yes	Yes	No
4P57A72671	BNFH	ThinkSystem 1100W 230V/115V Platinum Hot-Swap Gen2 Power Supply v3	TCE	2	Yes	Yes	Yes	No
4P57A78362	BMUF	ThinkSystem 1800W 230V Platinum Hot-Swap Gen2 Power Supply v2	TCE	2	No	Yes	Yes	No
-48V DC input power								
4P57A89415	CCTL	ThinkSystem 1100W -48V DC Hot-Swap Gen2 Power Supply v2	Not TCE	2	No	No	No	Yes

Supported power supplies are auto-sensing dual-voltage units, supporting both 110V AC (100-127V 50/60 Hz) and 220V AC (200-240V 50/60 Hz) power. For China customers, all power supplies support 240V DC. All supported AC power supplies have a C14 connector.

Power supply options do not include a line cord. For server configurations, the inclusion of a power cord is model dependent. Configure-to-order models can be configured without power cords if desired.

The ThinkSystem 1100W -48V DC Hot-Swap Gen2 Power Supply v2 (4P57A89415) has a Weidmuller TOP 4GS/3 7.6 terminal as shown in the following figure.

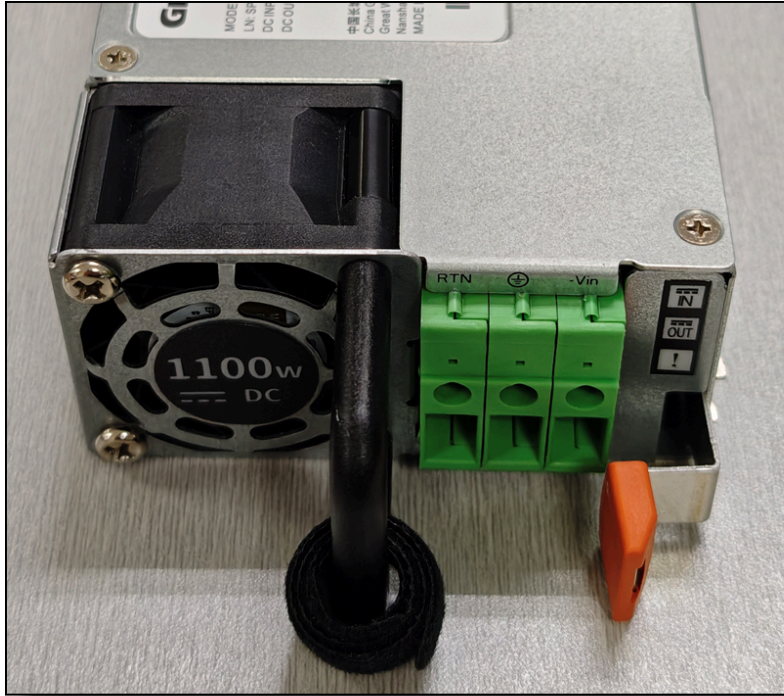

Figure 19. Connector on the ThinkSystem 1100W -48V DC Hot-Swap Gen2 Power Supply v2 (4P57A89415)

Power supply LEDs

The supported hot-swap power supplies have the following LEDs:

- Power input LED:
 - Green: The power supply is connected to the AC power source
 - Off: The power supply is disconnected from the AC power source or a power problem has occurred
- Power output LED:
 - Green: The server is on and the power supply is working normally
 - Blinking green: The power supply is in Zero-output/Standby mode (see below)
 - Off: The server is powered off, or the power supply is not working properly
- Power supply error LED:
 - Off: The power supply is working normally
 - Yellow: The power supply has failed

Power cords (C13 connectors)

Line cords and rack power cables with C13 connectors can be ordered as listed in the following table.

115V customers: If you plan to use the 1100W power supply with a low-range (100-127V) power source, select a power cable that is rated above 10A. Power cables that are rated at 10A or below are not supported with low-range power.

Table 78. Power cords

Part number	Feature code	Description	Top Choice Express
Rack cables - C13 to C14			
CTO only	BPHZ	0.5m, 10A/100-250V, C13 to C14 Jumper Cord	Not TCE
00Y3043	A4VP	1.0m, 10A/100-250V, C13 to C14 Jumper Cord	TCE ⓘ
4L67A08367	B0N5	1.0m, 13A/100-250V, C13 to C14 Jumper Cord	TCE
39Y7937	6201	1.5m, 10A/100-250V, C13 to C14 Jumper Cord	TCE
4L67A08368	B0N6	1.5m, 13A/100-250V, C13 to C14 Jumper Cord	TCE
4L67A08365	B0N4	2.0m, 10A/100-250V, C13 to C14 Jumper Cord	TCE
4L67A08369	6570	2.0m, 13A/100-250V, C13 to C14 Jumper Cord	TCE
4L67A08366	6311	2.8m, 10A/100-250V, C13 to C14 Jumper Cord	TCE
4L67A08370	6400	2.8m, 13A/100-250V, C13 to C14 Jumper Cord	TCE
39Y7932	6263	4.3m, 10A/100-250V, C13 to C14 Jumper Cord	TCE
4L67A08371	6583	4.3m, 13A/100-250V, C13 to C14 Rack Power Cable	TCE
Rack cables for India - C13 to C14			
4L67B10326	CC6R	2.0m, 10A/100-250V, C13 to C14 Jumper Cord (India)	Not TCE
4L67B10327	CC6S	2.8m, 10A/100-250V, C13 to C14 Jumper Cord (India)	Not TCE
4L67B10328	CC6T	4.3m, 10A/100-250V, C13 to C14 Jumper Cord (India)	Not TCE
Rack cables - C13 to C14 (Y-cable)			
00Y3046	A4VQ	1.345m, 2X C13 to C14 Jumper Cord, Rack Power Cable	Not TCE
00Y3047	A4VR	2.054m, 2X C13 to C14 Jumper Cord, Rack Power Cable	Not TCE
Rack cables - C13 to C20			
39Y7938	6204	2.8m, 10A/100-250V, C13 to IEC 320-C20 Rack Power Cable	TCE
Rack cables - C13 to C20 (Y-cable)			
47C2491	A3SW	1.2m, 16A/100-250V, 2 Short C13s to Short C20 Rack Power Cable	Not TCE
47C2492	A3SX	2.5m, 16A/100-250V, 2 Long C13s to Short C20 Rack Power Cable	Not TCE
47C2493	A3SY	2.8m, 16A/100-250V, 2 Short C13s to Long C20 Rack Power Cable	Not TCE
47C2494	A3SZ	4.1m, 16A/100-250V, 2 Long C13s to Long C20 Rack Power Cable	Not TCE
Line cords			
39Y7930	6222	2.8m, 10A/250V, C13 to IRAM 2073 (Argentina) Line Cord	TCE ⓘ
81Y2384	6492	4.3m 10A/220V, C13 to IRAM 2073 (Argentina) Line Cord	TCE ⓘ
39Y7924	6211	2.8m, 10A/250V, C13 to AS/NZ 3112 (Australia/NZ) Line Cord	TCE ⓘ
81Y2383	6574	4.3m, 10A/230V, C13 to AS/NZS 3112 (Aus/NZ) Line Cord	TCE ⓘ
69Y1988	6532	2.8m, 10A/250V, C13 to NBR 14136 (Brazil) Line Cord	TCE ⓘ
81Y2387	6404	4.3m, 10A/250V, C13 - 2P+Gnd (Brazil) Line Cord	TCE ⓘ
39Y7928	6210	2.8m, 10A/220V, C13 to GB 2099.1 (China) Line Cord	Not TCE
81Y2378	6580	4.3m, 10A/220V, C13 to GB 2099.1 (China) Line Cord	Not TCE
39Y7918	6213	2.8m, 10A/250V, C13 to DK2-5a (Denmark) Line Cord	Not TCE
81Y2382	6575	4.3m, 10A/230V, C13 to DK2-5a (Denmark) Line Cord	Not TCE
39Y7917	6212	2.8m, 10A/230V, C13 to CEE7-VII (Europe) Line Cord	TCE
81Y2376	6572	4.3m, 10A/230V, C13 to CEE7-VII (Europe) Line Cord	Not TCE

Part number	Feature code	Description	Top Choice Express
39Y7927	6269	2.8m, 10A/250V, C13(2P+Gnd) (India) Line Cord	TCE ⓘ
81Y2386	6567	4.3m, 10A/240V, C13 to IS 6538 (India) Line Cord	TCE ⓘ
39Y7920	6218	2.8m, 10A/250V, C13 to SI 32 (Israel) Line Cord	TCE
81Y2381	6579	4.3m, 10A/230V, C13 to SI 32 (Israel) Line Cord	Not TCE
39Y7921	6217	2.8m, 220-240V, C13 to CEI 23-16 (Italy/Chile) Line Cord	TCE ⓘ
81Y2380	6493	4.3m, 10A/230V, C13 to CEI 23-16 (Italy/Chile) Line Cord	TCE ⓘ
46M2593	A1RE	2.8m, 12A/125V, C13 to JIS C-8303 (Japan) Line Cord	TCE ⓘ
4L67A08362	6495	4.3m, 12A/200V, C13 to JIS C-8303 (Japan) Line Cord	Not TCE
39Y7926	6335	4.3m, 12A/100V, C13 to JIS C-8303 (Japan) Line Cord	TCE
39Y7922	6214	2.8m, 10A/250V, C13 to SABS 164 (S Africa) Line Cord	TCE ⓘ
81Y2379	6576	4.3m, 10A/230V, C13 to SABS 164 (South Africa) Line Cord	TCE ⓘ
39Y7925	6219	2.8m, 220-240V, C13 to KETI (S Korea) Line Cord	TCE ⓘ
81Y2385	6494	4.3m, 12A/220V, C13 to KSC 8305 (S. Korea) Line Cord	TCE ⓘ
39Y7919	6216	2.8m, 10A/250V, C13 to SEV 1011-S24507 (Swiss) Line Cord	TCE ⓘ
81Y2390	6578	4.3m, 10A/230V, C13 to SEV 1011-S24507 (Sws) Line Cord	Not TCE
23R7158	6386	2.8m, 10A/125V, C13 to CNS 10917-3 (Taiwan) Line Cord	TCE ⓘ
81Y2375	6317	2.8m, 10A/240V, C13 to CNS 10917-3 (Taiwan) Line Cord	TCE ⓘ
81Y2374	6402	2.8m, 13A/125V, C13 to CNS 60799 (Taiwan) Line Cord	TCE ⓘ
4L67A08363	AX8B	4.3m, 10A 125V, C13 to CNS 10917 (Taiwan) Line Cord	TCE ⓘ
81Y2389	6531	4.3m, 10A/250V, C13 to 76 CNS 10917-3 (Taiwan) Line Cord	TCE ⓘ
81Y2388	6530	4.3m, 13A/125V, C13 to CNS 10917 (Taiwan) Line Cord	TCE ⓘ
39Y7923	6215	2.8m, 10A/250V, C13 to BS 1363/A (UK) Line Cord	TCE
81Y2377	6577	4.3m, 10A/230V, C13 to BS 1363/A (UK) Line Cord	TCE
90Y3016	6313	2.8m, 10A/120V, C13 to NEMA 5-15P (US) Line Cord	TCE
46M2592	A1RF	2.8m, 10A/250V, C13 to NEMA 6-15P Line Cord	TCE
00WH545	6401	2.8m, 13A/120V, C13 to NEMA 5-15P (US) Line Cord	TCE
4L67A08359	6370	4.3m, 10A/125V, C13 to NEMA 5-15P (US) Line Cord	TCE
4L67A08361	6373	4.3m, 10A/250V, C13 to NEMA 6-15P (US) Line Cord	TCE
4L67A08360	AX8A	4.3m, 13A/120V, C13 to NEMA 5-15P (US) Line Cord	TCE

-48V DC power cord

For the -48V DC Power Supply, the following power cable is supported.

Table 79. -48V DC power cable

Part number	Feature code	Description	Top Choice Express
4X97A59831	BE4V	2.5m, -48VDC Interconnecting Cable	Not TCE

Systems management

The SR645 V3 contains an integrated service processor, XClarity Controller 2 (XCC), which provides advanced control, monitoring, and alerting functions. The XCC2 is based on the AST2600 baseboard management controller (BMC) using a dual-core ARM Cortex A7 32-bit RISC service processor running at 1.2 GHz.

Topics in this section:

- [System I/O Board](#)
- [Local management](#)
- [System status with XClarity Mobile](#)
- [Remote management](#)
- [XCC2 Platinum](#)
- [Lenovo XClarity Provisioning Manager](#)
- [Lenovo XClarity One](#)
- [Lenovo XClarity Administrator](#)
- [Lenovo XClarity Integrators](#)
- [Lenovo XClarity Essentials](#)
- [Lenovo XClarity Energy Manager](#)
- [Lenovo Capacity Planner](#)

System I/O Board

The SR645 V3 implements a separate System I/O Board that connects to the Processor Board. The location of the System I/O Board is shown in the [Components and connectors](#) section. The System I/O Board contains all the connectors visible at the rear of the server as shown in the following figure.

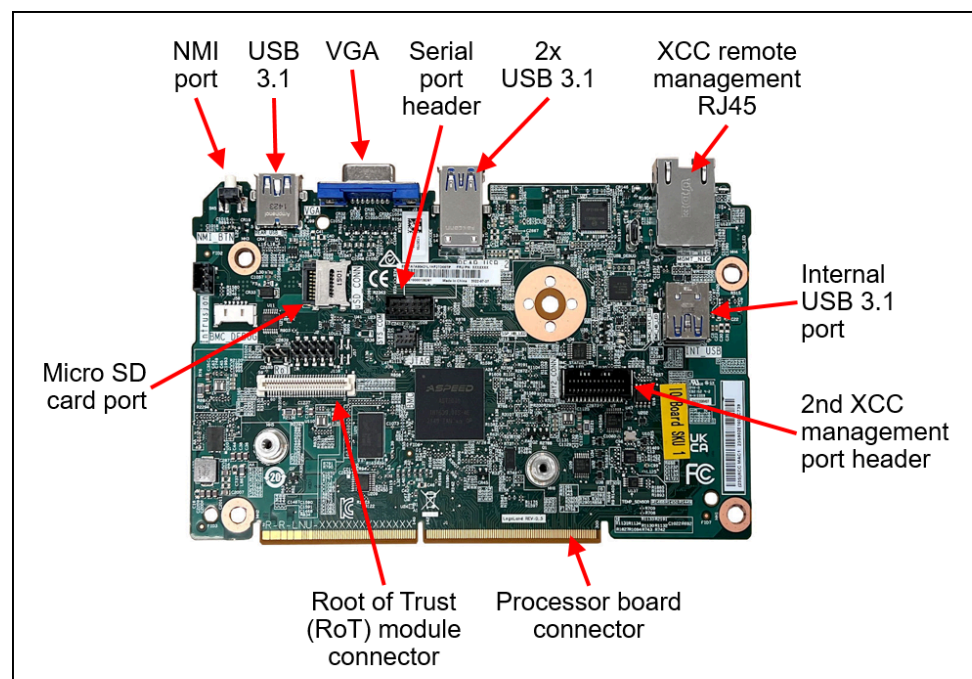

Figure 20. System I/O Board

The board also has the following components:

- XClarity Controller 2, implemented using the ASPEED AST2600 baseboard management controller (BMC).

- Root of Trust (RoT) module - a daughter card that implements Platform Firmware Resiliency (PFR) hardware Root of Trust (RoT) which enables the server to be NIST SP800-193 compliant. For more details about PFR, see the [Security](#) section.
- Connector to enable an additional redundant Ethernet connection to the XCC2 controller. The connector is used in conjunction with the ThinkSystem V3 Management NIC Adapter Kit (4XC7A85319). For details, see the [Remote management](#) section.
- Internal USB port - to allow the booting of an operating system from a USB key. The VMware ESXi preloads use this port for example. Preloads are described in the [Operating system support](#) section.
- MicroSD card port to enable the use of a MicroSD card for additional storage for use with the XCC2 controller. XCC2 can use the storage as a Remote Disc on Card (RDOC) device (up to 4GB of storage). It can also be used to store firmware updates (including N-1 firmware history) for ease of deployment.

Tip: Without a MicroSD card installed, the XCC2 controller will have 100MB of available RDOC storage.

Ordering information for the supported USB drive and Micro SD card are listed in the following table.

Table 80. Media for use with the System I/O Board

Part number	Feature code	Description	Top Choice Express
4X77A77065	BNWN	ThinkSystem USB 32GB USB 3.0 Flash Drive	Not TCE
4X77A77064	BNWP	ThinkSystem MicroSD 32GB Class 10 Flash Memory Card	TCE
4X77A92672	C0BC	ThinkSystem MicroSD 64GB Class 10 Flash Memory Card	Not TCE

Local management

The SR645 V3 offers a front operator panel with key LED status indicators, as shown in the following figure.

Tip: The Network LED only shows network activity of the installed OCP network adapter.

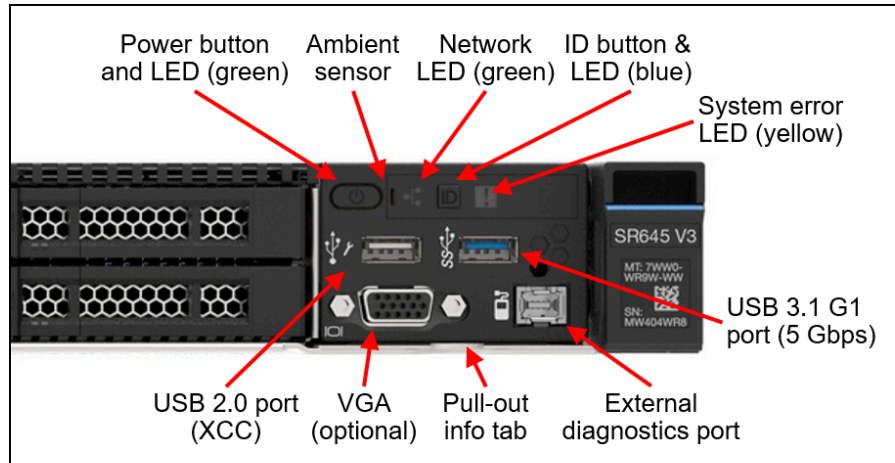

Figure 21. Front operator panel

Light path diagnostics

The server offers light path diagnostics. If an environmental condition exceeds a threshold or if a system component fails, the XCC lights LEDs inside the server to help you diagnose the problem and find the failing part. The server has fault LEDs next to the following components:

- Each memory DIMM
- Each drive bay
- Each power supply

Integrated Diagnostics Panel for 8x 2.5-inch and EDSFF configurations

For configurations with 8x 2.5-inch drive bays or 16x EDSFF drive bays at the front, the server can optionally be configured to have a pull-out Integrated Diagnostics Panel. The following figure shows the configurations with the standard (fixed) operator panel and the optional Integrated Diagnostics Panel.

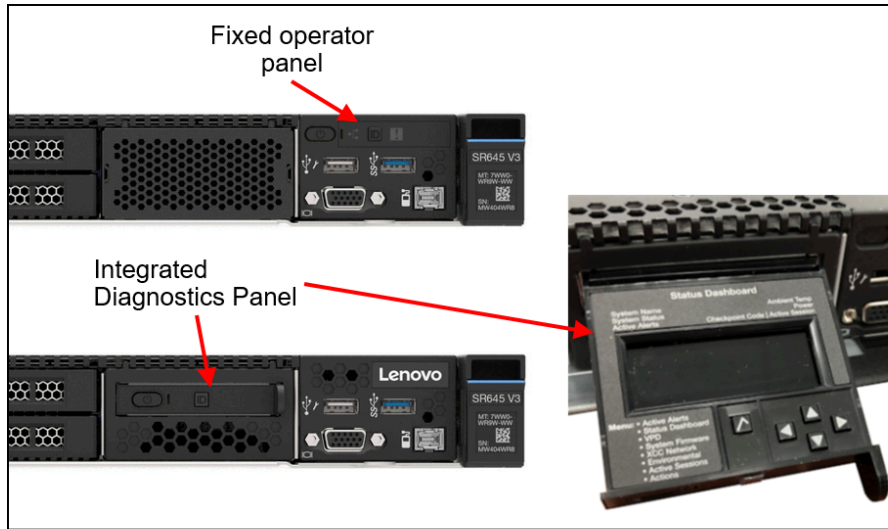

Figure 22. Operator panel choices for the EDSFF and 8x 2.5-inch drive bay configurations

The Integrated Diagnostics Panel allows quick access to system status, firmware, network, and health information. The LCD display on the panel and the function buttons give you access to the following information:

- Active alerts
- Status Dashboard
- System VPD: machine type & mode, serial number, UUID string
- System firmware levels: UEFI and XCC firmware
- XCC network information: hostname, MAC address, IP address, DNS addresses
- Environmental data: Ambient temperature, CPU temperature, AC input voltage, estimated power consumption
- Active XCC sessions
- System reset action

The Integrated Diagnostics Panel can be configured as listed in the following table. It is only available configure-to-order (CTO); not available as a field upgrade.

Table 81. Ordering information for the Integrated Diagnostics Panel

Part number	Feature code	Description	Top Choice Express
CTO only	B8NH	ThinkSystem 1U Integrated Diagnostics Panel	Not TCE

Configuration rules for the Pull-out operator panel:

- Only supported with configurations with 8x 2.5-inch drive bays or with EDSFF drive bays
- Not available as a field upgrade. The component is CTO or on pre-configured models only

Front VGA and External Diagnostics ports

The VGA port at the rear of the server is included in all models, however the VGA port at the front of the server is optional. The ThinkSystem V2/V3 1U Front VGA Cable Option Kit allows you to upgrade your server by adding a VGA video port to the front of the server (if the server does not already come with a front VGA port). When the front VGA is in use, the rear VGA port is automatically disabled.

The SR645 V3 optionally includes a port to connect an External Diagnostics Handset. To include in a server, ensure the appropriate feature code is included, based on the front drive configuration. Field upgrades to add the External Diagnostics port are not available.

Table 82. Front VGA and External Diagnostics ports

Part number	Feature code	Description	Top Choice Express
Optional VGA port (adds the VGA port to the front of the server)			
4X97A12644	BA2Y	ThinkSystem V2/V3 1U Front VGA Cable Option Kit	TCE
Optional port for the External Diagnostic Handset (adds the port to the front of the server)			
CTO only	BLKD	ThinkSystem 1U V3 10x2.5" Media Bay w/ Ext. Diagnostics Port	TCE
CTO only	B8NN	ThinkSystem 1U V3 8x2.5" Media Bay w/ External Diagnostics Port	Not TCE
CTO only	BR03	ThinkSystem 1U 4x3.5" Media Bay w/ External Diagnostics Port	TCE

External Diagnostics Handset

The SR645 V3 optionally includes a port to connect an External Diagnostics Handset as described in the previous section. The External Diagnostics Handset has the same functions as the Integrated Diagnostics Panel but has the advantages of not consuming space on the front of the server plus it can be shared among many servers in your data center. The handset has a magnet on the back of it to allow you to easily mount it on a convenient place on any rack cabinet.

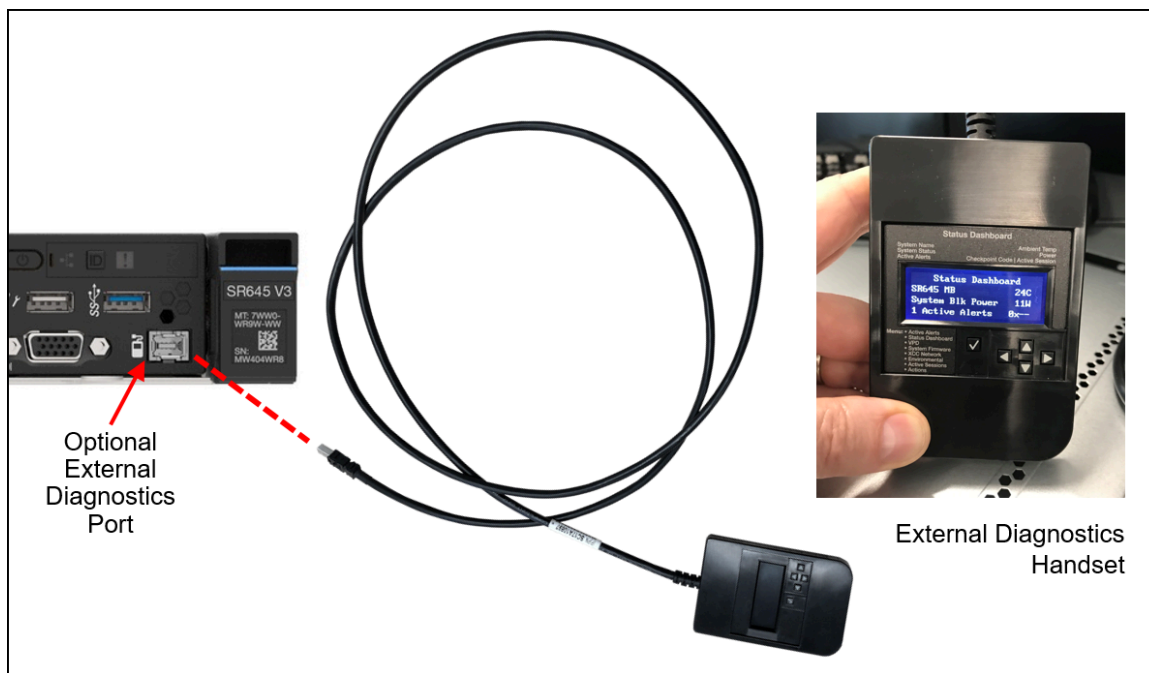

Figure 23. External Diagnostics Handset

The following table lists the ordering information for the handset.

Table 83. External Diagnostics Handset ordering information

Part number	Feature code	Description	Top Choice Express
4TA7A64874	BEUX	ThinkSystem External Diagnostics Handset	Not TCE

Information pull-out tab

The front of the server also houses an information pull-out tab (also known as the network access tag). See [Figure 2](#) for the location. A label on the tab shows the network information (MAC address and other data) to remotely access the service processor.

System status with XClarity Mobile

The XClarity Mobile app includes a tethering function where you can connect your Android or iOS device to the server via USB to see the status of the server.

The steps to connect the mobile device are as follows:

1. Enable USB Management on the server, by holding down the ID button for 3 seconds (or pressing the dedicated USB management button if one is present)
2. Connect the mobile device via a USB cable to the server's USB port with the management symbol 
3. In iOS or Android settings, enable Personal Hotspot or USB Tethering
4. Launch the Lenovo XClarity Mobile app

Once connected you can see the following information:

- Server status including error logs (read only, no login required)
- Server management functions (XClarity login credentials required)

Remote management

The server offers a dedicated RJ45 Ethernet port at the rear of the server for remote management via the XClarity Controller 2 management processor. The port supports 10/100/1000 Mbps speeds.

Remote server management is provided through industry-standard interfaces:

- Intelligent Platform Management Interface (IPMI) Version 2.0
- Simple Network Management Protocol (SNMP) Version 3 (no SET commands; no SNMP v1)
- Common Information Model (CIM-XML)
- Representational State Transfer (REST) support
- Redfish support (DMTF compliant)
- Web browser - HTML 5-based browser interface (Java and ActiveX not required) using a responsive design (content optimized for device being used - laptop, tablet, phone) with NLS support

The SR645 V3 also supports the use of an OCP adapter that provides an additional redundant Ethernet connection to the XCC2 controller. Ordering information is listed in the following table.

Table 84. Redundant System Management Port Adapter

Part number	Feature code	Description	Top Choice Express	Maximum quantity
4XC7A85319	BTMQ	ThinkSystem V3 Management NIC Adapter Kit	Not TCE	1

The use of this adapter allows concurrent remote access using both the connection on the adapter and the onboard RJ45 remote management port provided by the server. The adapter and onboard port have separate IP addresses.

Configuration rules:

- The Redundant System Management Port Adapter is installed in the OCP adapter slot at the rear of the server and is mutually exclusive with any OCP network adapter.

- It is not supported installed in the front OCP slot (if the front OCP slot is configured)
- If the Redundant System Management Port Adapter is installed in the rear slot, then the front OCP slot (if configured) cannot be used.

The following figure shows the server with the Redundant System Management Port Adapter installed in the OCP slot.

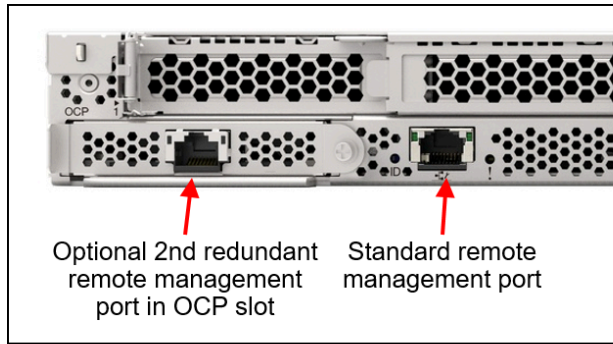

Figure 24. SR645 V3 with the Redundant System Management Port Adapter installed

IPMI via the Ethernet port (IPMI over LAN) is supported, however it is disabled by default. For CTO orders you can specify whether you want to the feature enabled or disabled in the factory, using the feature codes listed in the following table.

Table 85. IPMI-over-LAN settings

Feature code	Description	Top Choice Express
B7XZ	Disable IPMI-over-LAN (default)	TCE
B7Y0	Enable IPMI-over-LAN	TCE

XCC2 Platinum

The XCC2 service processor in the SR645 V3 supports an upgrade to the Platinum level of features. Compared to the XCC functions of ThinkSystem V2 and earlier systems, Platinum adds the same features as Enterprise and Advanced levels in ThinkSystem V2, plus additional features.

XCC2 Platinum adds the following Enterprise and Advanced functions:

- Remotely viewing video with graphics resolutions up to 1600x1200 at 75 Hz with up to 23 bits per pixel, regardless of the system state
- Remotely accessing the server using the keyboard and mouse from a remote client
- International keyboard mapping support
- Syslog alerting
- Redirecting serial console via SSH
- Component replacement log (Maintenance History log)
- Access restriction (IP address blocking)
- Lenovo SED security key management
- Displaying graphics for real-time and historical power usage data and temperature
- Boot video capture and crash video capture
- Virtual console collaboration - Ability for up to 6 remote users to be log into the remote session simultaneously
- Remote console Java client
- Mapping the ISO and image files located on the local client as virtual drives for use by the server
- Mounting the remote ISO and image files via HTTPS, SFTP, CIFS, and NFS
- System utilization data and graphic view

- Single sign on with Lenovo XClarity Administrator
- Update firmware from a repository
- License for XClarity Energy Manager

Note: The SR645 V3 does not support Power capping.

XCC2 Platinum also adds the following features that are new to XCC2:

- System Guard - Monitor hardware inventory for unexpected component changes, and simply log the event or prevent booting
- Enterprise Strict Security mode - Enforces CNSA 1.0 level security
- Neighbor Group - Enables administrators to manage and synchronize configurations and firmware level across multiple servers

Ordering information is listed in the following table. XCC2 Platinum is a software license upgrade - no additional hardware is required.

Table 86. XCC2 Platinum license upgrade

Part number	Feature code	Description
7S0X000KWW	SBCV	Lenovo XClarity Controller 2 (XCC2) Platinum Upgrade

With XCC2 Platinum, for CTO orders, you can request that System Guard be enabled in the factory and the first configuration snapshot be recorded. To add this to an order, select feature code listed in the following table. The selection is made in the Security tab of the DCSC configurator.

Table 87. Enable System Guard in the factory (CTO orders)

Feature code	Description	Top Choice Express
BUT2	Install System Guard	TCE

For more information about System Guard, see https://pubs.lenovo.com/xcc2/NN1ia_c_systemguard

Lenovo XClarity Provisioning Manager

Lenovo XClarity Provisioning Manager (LXPM) is a UEFI-based application embedded in ThinkSystem servers and accessible via the F1 key during system boot.

LXPM provides the following functions:

- Graphical UEFI Setup
- System inventory information and VPD update
- System firmware updates (UEFI and XCC)
- RAID setup wizard
- OS installation wizard (including unattended OS installation)
- Diagnostics functions

Lenovo XClarity One

Lenovo XClarity One is a hybrid cloud-based unified Management-as-a-Service (MaaS) platform, built for growing enterprises. XClarity One is powered by Lenovo Smarter Support, a powerful AI-driven platform that leverages predictive analytics to enhance the performance, reliability, and overall efficiency of Lenovo servers.

XClarity One is the next milestone in Lenovo's portfolio of systems management products. Now you can leverage the benefits of a true next-generation, hybrid cloud-based solution for the deployment,

management, and maintenance of your infrastructure through a single, centralized platform that delivers a consistent user experience across all Lenovo products.

Key features include:

- **AI-powered Automation**

Harnesses the power of AI and predictive analytics to enhance the performance and reliability of your infrastructure with proactive protection.

- **AI-Powered Predictive Failure Analytics** - predict maintenance needs before the failure occurs, with the ability to visualize aggregated actions in customer dashboard.
- **AI-Powered Call-Home** - A Call-Home serviceable event opens a support ticket automatically, leveraging AI technology for problem determination and fast resolution.
- **AI-Powered Premier Support with Auto CRU** - uses AI to automatically dispatch parts and services, reducing service costs and minimizing downtime.

- **Secure Management Hub**

Lenovo's proprietary Management Hub is an on-premises virtual appliance that acts as the bridge between your infrastructure and the cloud.

- **On-Premises Security with Cloud Flexibility** - your infrastructure has no direct connection to the cloud, greatly reducing your attack surface from external threats while still having the deployment benefits, flexibility, and scalability of a cloud solution.
- **Authentication and Authorization** - built on a Zero Trust Architecture and requiring OTP Application authentication for all users to handle the support of all customers' servers and client devices. Role-based access controls help define and restrict permissions based on user roles.

- **AI-Powered Management**

Go beyond standard system management leveraging AI algorithms to continuously learn from data patterns to optimize performance and predict potential issues before they impact operations.

- **AI Customizable Insights and Reporting** - Customize AI-generated insights and reports to align with specific business objectives, enabling data-driven decision-making and strategic planning.
- **AI-driven scalability and flexibility** - Guided with AI-driven predictions, the platform supports dynamic scaling of resources based on workload demands.
- **Monitor and Change** - AI Advanced analytics capabilities providing deep insights into server performance, resource utilization, and security threats, to detect anomalies and suggest optimizations in real-time. NLP capabilities enabling administrators to interact with the platform using voice commands or text queries.
- **Upward Integration** - Integrated with Lenovo Open Cloud Automation (LOC-A), Lenovo Intelligent Computer Orchestration (LiCO) and AIOps engines providing an end-to-end management architecture across Lenovo infrastructure and devices solutions.
- **Cross-Platform Compatibility** - Compatibility across different server types and cloud environments

Lenovo XClarity One is an optional management component. License information for XClarity One is listed in the following table.

Table 88. XClarity One license information

Part number	Feature code	Description
Subscription license		
7S0X000LWW	SCJC	XClarity One - Managed Device, Per Endpoint w/1 Yr SW S&S
7S0X000MWW	SCJD	XClarity One - Managed Device, Per Endpoint w/3 Yr SW S&S

Part number	Feature code	Description
7S0X000NWW	SCJE	XClarity One - Managed Device, Per Endpoint w/5 Yr SW S&S

For more information, see these resources:

- Lenovo XClarity One datasheet:
<https://lenovopress.lenovo.com/ds0188-lenovo-xclarity-one>
- Lenovo XClarity One product guide:
<https://lenovopress.lenovo.com/lp1992-lenovo-xclarity-one>

Lenovo XClarity Administrator

Lenovo XClarity Administrator is a centralized resource management solution designed to reduce complexity, speed response, and enhance the availability of Lenovo systems and solutions. It provides agent-free hardware management for ThinkSystem servers. The administration dashboard is based on HTML 5 and allows fast location of resources so tasks can be run quickly.

Because Lenovo XClarity Administrator does not require any agent software to be installed on the managed endpoints, there are no CPU cycles spent on agent execution, and no memory is used, which means that up to 1GB of RAM and 1 - 2% CPU usage is saved, compared to a typical managed system where an agent is required.

Lenovo XClarity Administrator is an optional software component for the SR645 V3. The software can be downloaded and used at no charge to discover and monitor the SR645 V3 and to manage firmware upgrades.

If software support is required for Lenovo XClarity Administrator, or premium features such as configuration management and operating system deployment are required, Lenovo XClarity Pro software subscription should be ordered. Lenovo XClarity Pro is licensed on a per managed system basis, that is, each managed Lenovo system requires a license.

The following table lists the Lenovo XClarity software license options.

Table 89. Lenovo XClarity Pro ordering information

Part number	Feature code	Description
00MT201	1339	Lenovo XClarity Pro, per Managed Endpoint w/1 Yr SW S&S
00MT202	1340	Lenovo XClarity Pro, per Managed Endpoint w/3 Yr SW S&S
00MT203	1341	Lenovo XClarity Pro, per Managed Endpoint w/5 Yr SW S&S
7S0X000HWW	SAYV	Lenovo XClarity Pro, per Managed Endpoint w/6 Yr SW S&S
7S0X000JWW	SAYW	Lenovo XClarity Pro, per Managed Endpoint w/7 Yr SW S&S

Lenovo XClarity Administrator offers the following standard features that are available at no charge:

- Auto-discovery and monitoring of Lenovo systems
- Firmware updates and compliance enforcement
- External alerts and notifications via SNMP traps, syslog remote logging, and e-mail
- Secure connections to managed endpoints
- NIST 800-131A or FIPS 140-3 compliant cryptographic standards between the management solution and managed endpoints
- Integration into existing higher-level management systems such as cloud automation and orchestration tools through REST APIs, providing extensive external visibility and control over hardware resources
- An intuitive, easy-to-use GUI
- Scripting with Windows PowerShell, providing command-line visibility and control over hardware resources

Lenovo XClarity Administrator offers the following premium features that require an optional Pro license:

- Pattern-based configuration management that allows to define configurations once and apply repeatedly without errors when deploying new servers or redeploying existing servers without disrupting the fabric
- Bare-metal deployment of operating systems and hypervisors to streamline infrastructure provisioning

For more information, refer to the Lenovo XClarity Administrator Product Guide:

<http://lenovopress.com/tips1200>

Lenovo XClarity Integrators

Lenovo also offers software plug-in modules, Lenovo XClarity Integrators, to manage physical infrastructure from leading external virtualization management software tools including those from Microsoft and VMware.

These integrators are offered at no charge, however if software support is required, a Lenovo XClarity Pro software subscription license should be ordered.

Lenovo XClarity Integrators offer the following additional features:

- Ability to discover, manage, and monitor Lenovo server hardware from VMware vCenter or Microsoft System Center
- Deployment of firmware updates and configuration patterns to Lenovo x86 [rack servers](#) and Flex System from the virtualization management tool
- Non-disruptive server maintenance in clustered environments that reduces workload downtime by dynamically migrating workloads from affected hosts during rolling server updates or reboots
- Greater service level uptime and assurance in clustered environments during unplanned hardware events by dynamically triggering workload migration from impacted hosts when impending hardware failures are predicted

For more information about all the available Lenovo XClarity Integrators, see the Lenovo XClarity Administrator Product Guide: <https://lenovopress.com/tips1200-lenovo-xclarity-administrator>

Lenovo XClarity Essentials

Lenovo offers the following XClarity Essentials software tools that can help you set up, use, and maintain the server at no additional cost:

- **Lenovo Essentials OneCLI**
OneCLI is a collection of server management tools that uses a command line interface program to manage firmware, hardware, and operating systems. It provides functions to collect full system health information (including health status), configure system settings, and update system firmware and drivers.
- **Lenovo Essentials UpdateXpress**
The UpdateXpress tool is a standalone GUI application for firmware and device driver updates that enables you to maintain your server firmware and device drivers up-to-date and help you avoid unnecessary server outages. The tool acquires and deploys individual updates and UpdateXpress System Packs (UXSPs) which are integration-tested bundles.
- **Lenovo Essentials Bootable Media Creator**
The Bootable Media Creator (BOMC) tool is used to create bootable media for offline firmware update.

For more information and downloads, visit the Lenovo XClarity Essentials web page:

<http://support.lenovo.com/us/en/documents/LNVO-center>

Lenovo XClarity Energy Manager

Lenovo XClarity Energy Manager (LXEM) is a power and temperature management solution for data centers. It is an agent-free, web-based console that enables you to monitor and manage power consumption and temperature in your data center through the management console.

LXEM is a licensed product. A single-node LXEM license is included with the XClarity Controller Platinum upgrade as described in the [XCC2 Platinum](#) section. If your server does not have the XCC Platinum upgrade, Energy Manager licenses can be ordered as shown in the following table.

Table 90. Lenovo XClarity Energy Manager

Part number	Description
4L40E51621	Lenovo XClarity Energy Manager Node License (1 license needed per server)

Note: The SR645 V3 does not support the following Energy Manager functions:

- Power capping
- Policy-based management

For more information about XClarity Energy Manager, see the following resources:

- **Lenovo Support page:**
<https://datacentersupport.lenovo.com/us/en/solutions/lnvo-lxem>
- **User Guide for XClarity Energy Manager:**
<https://pubs.lenovo.com/lxem/>

Lenovo Capacity Planner

Lenovo Capacity Planner is a power consumption evaluation tool that enhances data center planning by enabling IT administrators and pre-sales professionals to understand various power characteristics of racks, servers, and other devices. Capacity Planner can dynamically calculate the power consumption, current, British Thermal Unit (BTU), and volt-ampere (VA) rating at the rack level, improving the planning efficiency for large scale deployments.

For more information, refer to the Capacity Planner web page:

<http://datacentersupport.lenovo.com/us/en/solutions/Invo-lcp>

Security

Topics in this section:

- [Security features](#)
- [Platform Firmware Resiliency - Lenovo ThinkShield](#)
- [Security standards](#)

Security features

The SR645 V3 server offers the following electronic security features:

- Secure Boot function of the AMD EPYC processor
- Support for Platform Firmware Resiliency (PFR) hardware Root of Trust (RoT) - see the [Platform Firmware Resiliency](#) section
- Firmware signature processes compliant with FIPS and NIST requirements
- System Guard (part of [XCC Platinum](#)) - Proactive monitoring of hardware inventory for unexpected component changes
- Administrator and power-on password
- Integrated Trusted Platform Module (TPM) supporting TPM 2.0
- Self-encrypting drives (SEDs) with support for enterprise key managers - see the [SED encryption key management](#) section

The server is NIST SP 800-147B compliant.

The SR645 V3 server also offers the following optional physical security features:

- Optional chassis intrusion switch
- Optional lockable front security bezel

The optional lockable front security bezel is shown in the following figure and includes a key that enables you to secure the bezel over the drives and system controls thereby reducing the chance of unauthorized or accidental access to the server.

Front PCIe slots: The use of the security bezel is not supported when the server has front PCIe slots.



Figure 25. Lockable front security bezel

The dimensions of the security bezel are:

- Width: 437 mm (17.2 in.)
- Height: 43 mm (1.3 in.)
- Width: 23 mm (0.9 in.)

The following table lists the physical security options for the SR645 V3.

Table 91. Physical security features

Part number	Feature code	Description	Top Choice Express
4X97A59835	BA2X	ThinkSystem 1U Intrusion Cable	TCE

Part number	Feature code	Description	Top Choice Express
4XH7A09890	B8NL	ThinkSystem V2 1U Security Bezel	TCE
4XH7A90346	BXBP	ThinkSystem V3 1U Security Bezel Option Kit	TCE

Tip: The only difference between security bezels 4XH7A09890 and 4XH7A90346 is the Lenovo logo: On 4XH7A09890, the logo is made from plastic; on 4XH7A90346, the logo is made from aluminum alloy.

Platform Firmware Resiliency - Lenovo ThinkShield

Lenovo's ThinkShield Security is a transparent and comprehensive approach to security that extends to all dimensions of our data center products: from development, to supply chain, and through the entire product lifecycle.

The ThinkSystem SR645 V3 includes Platform Firmware Resiliency (PFR) hardware Root of Trust (RoT) which enables the system to be NIST SP800-193 compliant. This offering further enhances key platform subsystem protections against unauthorized firmware updates and corruption, to restore firmware to an integral state, and to closely monitor firmware for possible compromise from cyber-attacks.

PFR operates upon the following server components:

- UEFI image – the low-level server firmware that connects the operating system to the server hardware
- XCC image – the management “engine” software that controls and reports on the server status separate from the server operating system
- FPGA image – the code that runs the server’s lowest level hardware controller on the motherboard

The Lenovo Platform Root of Trust Hardware performs the following three main functions:

- Detection – Measures the firmware and updates for authenticity
- Recovery – Recovers a corrupted image to a known-safe image
- Protection – Monitors the system to ensure the known-good firmware is not maliciously written

These enhanced protection capabilities are implemented using a dedicated, discrete security processor whose implementation has been rigorously validated by leading third-party security firms. Security evaluation results and design details are available for customer review – providing unprecedented transparency and assurance.

The SR645 V3 includes support for Secure Boot, a UEFI firmware security feature developed by the UEFI Consortium that ensures only immutable and signed software are loaded during the boot time. The use of Secure Boot helps prevent malicious code from being loaded and helps prevent attacks, such as the installation of rootkits. Lenovo offers the capability to enable secure boot in the factory, to ensure end-to-end protection. Alternatively, Secure Boot can be left disabled in the factory, allowing the customer to enable it themselves at a later point, if desired.

The following table lists the relevant feature code(s).

Table 92. Secure Boot options

Part number	Feature code	Description	Top Choice Express	Purpose
CTO only	BPKQ	TPM 2.0 with Secure Boot	TCE	Configure the system in the factory with Secure Boot enabled.
CTO only	BPKR	TPM 2.0	TCE	Configure the system without Secure Boot enabled. Customers can enable Secure Boot later if desired.

Tip: If Secure Boot is not enabled in the factory, it can be enabled later by the customer. However once Secure Boot is enabled, it cannot be disabled.

Security standards

The SR645 V3 supports the following security standards and capabilities:

- **Industry Standard Security Capabilities**
 - AMD CPU Enablement
 - AES-NI (Advanced Encryption Standard New Instructions)
 - GMET (Guest Mode Execute Trap)
 - Hardware-based side channel attack resilience enhancements
 - NX (No eXecute)
 - PSB (Platform Secure Boot)
 - Shadow Stack
 - SEV (Secure Encrypted Virtualization)
 - SEV-ES (Encrypted State register encryption)
 - SEV-SNP (Secure Nested Paging)
 - SME (Secure Memory Encryption)
 - SVM (Secure Virtual Machine)
 - UMIP (User Mode Instruction Prevention)
 - Microsoft Windows Security Enablement
 - Credential Guard
 - Device Guard
 - Host Guardian Service
 - TPM 2.0 (Trusted Platform Module 2.0)
 - UEFI (Unified Extensible Firmware Interface) Forum Secure Boot
- **Hardware Root of Trust and Security**
 - Independent security subsystem providing platform-wide NIST SP800-193 compliant Platform Firmware Resilience (PFR)
 - Host domain RoT supplemented by AMD Platform Secure Boot (PSB)
 - Management domain RoT provided by the Secure Boot feature of the AST2600 Baseboard Management Controller (BMC)
- **Platform Security**
 - Boot and run-time firmware integrity monitoring with rollback to known-good firmware (e.g., “self-healing”)
 - Non-volatile storage bus security monitoring and filtering
 - Resilient firmware implementation, such as to detect and defeat unauthorized flash writes or SMM (System Management Mode) memory incursions
 - Patented IPMI KCS channel privileged access authorization (USPTO Patent# 11,256,810)
 - Host and management domain authorization, including integration with CyberArk for enterprise password management
 - KMIP (Key Management Interoperability Protocol) compliant, including support for IBM SKLM and Thales KeySecure
 - Reduced “out of box” attack surface
 - Configurable network services
 - FIPS 140-3 (in progress) validated cryptography for XCC
 - CNSA Suite 1.0 Quantum-resistant cryptography for XCC

- Lenovo System Guard

For more information on platform security, see the paper “How to Harden the Security of your ThinkSystem Server and Management Applications” available from <https://lenovopress.com/lp1260-how-to-harden-the-security-of-your-thinksystem-server>.

- **Standards Compliance and/or Support**

- NIST SP800-131A rev 2 “Transitioning the Use of Cryptographic Algorithms and Key Lengths”
- NIST SP800-147B “BIOS Protection Guidelines for Servers”
- NIST SP800-193 “Platform Firmware Resiliency Guidelines”
- ISO/IEC 11889 “Trusted Platform Module Library”
- Common Criteria TCG Protection Profile for “PC Client Specific TPM 2.0”
- European Union Commission Regulation 2019/424 (“ErP Lot 9”) “Ecodesign Requirements for Servers and Data Storage Products” Secure Data Deletion
- Optional FIPS 140-2 validated Self-Encrypting Disks (SEDs) with external KMIP-based key management

- **Product and Supply Chain Security**

- Suppliers validated through Lenovo’s Trusted Supplier Program
- Developed in accordance with Lenovo’s Secure Development Lifecycle (LSDL)
- Continuous firmware security validation through automated testing, including static code analysis, dynamic network and web vulnerability testing, software composition analysis, and subsystem-specific testing, such as UEFI security configuration validation
- Ongoing security reviews by US-based security experts, with attestation letters available from our third-party security partners
- Digitally signed firmware, stored and built on US-based infrastructure and signed on US-based Hardware Security Modules (HSMs)
- TAA (Trade Agreements Act) compliant manufacturing, by default in Mexico for North American markets with additional US and EU manufacturing options
- US 2019 NDAA (National Defense Authorization Act) Section 889 compliant

Rack installation

The following table lists the rack installation options that are available for the SR645 V3.

Table 93. Rack installation options

Part number	Feature Code	Description	Top Choice Express
Rail slides			
4XF7A99129	C4TL	ThinkSystem Toolless Stab-in Slide Rail Kit V3	TCE
4XF7A99130	C4TM	ThinkSystem Toolless Stab-in Slide Rail Kit V3 with 1U CMA	TCE ⓘ
4M17A13564	BK7W	ThinkSystem SR250/SR150 Toolless Friction Rail	TCE
4M17A11754	B8LA	ThinkSystem Toolless Slide Rail Kit v2	TCE
4M17A11758	B8LC	ThinkSystem Toolless Slide Rail Kit v2 with 1U CMA	TCE
Enhanced Rail Kits			
4M17A11755	B8LB	ThinkSystem Toolless Slide Rail Kit v2 Enhanced	Not TCE
4XF7A89443	B8LD	ThinkSystem Toolless Slide Rail Kit v2 Enhanced with 1U CMA	Not TCE
Cable Management Arm			
7M27A05699	B136	ThinkSystem 1U CMA Upgrade Kit for Toolless Slide Rail	Not TCE

For the specification of the rail kits, see the ThinkSystem and ThinkEdge Rail Kit Reference:
<https://lenovopress.lenovo.com/p1838-thinksystem-and-thinkedge-rail-kit-reference#sr645-v3-support=SR645%2520V3>

Operating system support

The SR645 V3 with 5th Gen AMD EPYC processors supports the following operating systems:

- Microsoft Windows 10 (x64)
- Microsoft Windows 11
- Microsoft Windows Server 2019
- Microsoft Windows Server 2022
- Microsoft Windows Server 2025
- Red Hat Enterprise Linux 8.10
- Red Hat Enterprise Linux 9.4
- Red Hat Enterprise Linux 9.5
- Red Hat Enterprise Linux 9.6
- Red Hat Enterprise Linux 9.7
- Red Hat Enterprise Linux 10.0
- Red Hat Enterprise Linux 10.1
- SUSE Linux Enterprise Server 15 SP6
- SUSE Linux Enterprise Server 15 SP7
- SUSE Linux Enterprise Server 16
- Ubuntu 22.04 LTS 64-bit
- Ubuntu 24.04 LTS 64-bit
- VMware ESXi 8.0 U3
- VMware ESXi 9.0

The SR645 V3 with 4th Gen AMD EPYC processors supports the following operating systems:

- Microsoft Windows 10 (x64)
- Microsoft Windows 11
- Microsoft Windows Server 2019
- Microsoft Windows Server 2022
- Microsoft Windows Server 2025
- Red Hat Enterprise Linux 8.6
- Red Hat Enterprise Linux 8.7
- Red Hat Enterprise Linux 8.8
- Red Hat Enterprise Linux 8.9
- Red Hat Enterprise Linux 8.10
- Red Hat Enterprise Linux 9.0
- Red Hat Enterprise Linux 9.1
- Red Hat Enterprise Linux 9.2
- Red Hat Enterprise Linux 9.3
- Red Hat Enterprise Linux 9.4
- Red Hat Enterprise Linux 9.5
- Red Hat Enterprise Linux 9.6
- Red Hat Enterprise Linux 9.7
- Red Hat Enterprise Linux 10.0
- Red Hat Enterprise Linux 10.1
- SUSE Linux Enterprise Server 15 SP4
- SUSE Linux Enterprise Server 15 SP5
- SUSE Linux Enterprise Server 15 SP6
- SUSE Linux Enterprise Server 15 SP7
- SUSE Linux Enterprise Server 15 Xen SP4
- SUSE Linux Enterprise Server 15 Xen SP5
- SUSE Linux Enterprise Server 16
- Ubuntu 20.04 LTS 64-bit
- Ubuntu 22.04 LTS 64-bit
- Ubuntu 24.04 LTS 64-bit
- VMware ESXi 7.0 U3

- VMware ESXi 8.0
- VMware ESXi 8.0 U1
- VMware ESXi 8.0 U2
- VMware ESXi 8.0 U3
- VMware ESXi 9.0

For a complete list of supported, certified and tested operating systems, plus additional details and links to relevant web sites, see the Operating System Interoperability Guide:

- 5th Gen AMD EPYC: <https://lenovopress.lenovo.com/osig#servers=sr645-v3-5th-gen-epyc-7d9d-7d9c&support=all>
- 4th Gen AMD EPYC: <https://lenovopress.lenovo.com/osig#servers=sr645-v3-4th-gen-epyc-7d9d-7d9c&support=all>

For configure-to-order configurations, the SR645 V3 can be preloaded with VMware ESXi. Ordering information is listed in the following table.

Table 94. VMware ESXi preload

Part number	Feature code	Description	Top Choice Express
CTO only	BMEY	VMware ESXi 7.0 U3 (Factory Installed)	TCE
CTO only	BYC7	VMware ESXi 8.0 U2 (Factory Installed)	TCE
CTO only	BZ97	VMware ESXi 8.0 U3 (Factory Installed)	TCE
CTO only	C91V	VMware ESXi 9.0 (Factory Installed)	TCE

Configuration rule:

- An ESXi preload cannot be selected if the configuration includes an NVIDIA GPU (ESXi preload cannot include the NVIDIA driver)

You can download supported VMware vSphere hypervisor images from the following web page and install it using the instructions provided:

https://vmware.lenovo.com/content/custom_iso/

Windows 10 and Windows 11

The SR645 V3 can now run Windows 10 and Windows 11, however only a subset of adapters and drives can be installed. For ease of configuration, additional Base CTO models 7D9CCTO2WW and 7D9DCTO2WW have been created to assist building a configuration that can be used with the client operating systems. See the [Models](#) section for details.

The XClarity management toolset is supported with Windows 10 and Windows 11.

Windows client license: A Windows client license for the system cannot be ordered from Lenovo nor can the OS be preloaded on the system in the factory. For the Windows license and for preloads, please contact your Lenovo business partner. A Windows Pro license is required as a qualifying base OS license in order to use a client Volume License offering.

See the part number tables in the following sections to see which adapters are supported with Windows 10 and Windows 11:

- [Controllers for internal storage](#)
- [M.2 adapters](#)
- [Network adapters](#)
- [GPU adapters](#)

GPU recommended: Lenovo recommends that if you plan to install Windows 10 or 11 on this server to run graphics-intensive applications, then you should selected a dedicated graphics adapter (GPU).

The following components are not supported:

- Fibre Channel adapters
- InfiniBand and VPI adapters
- External storage adapters
- Flash storage adapters

Physical and electrical specifications

The SR645 V3 has the following overall physical dimensions, excluding components that extend outside the standard chassis, such as EIA flanges, front security bezel (if any), and power supply handles:

- Width: 440 mm (17.3 inches)
- Height: 43 mm (1.7 inches)
- Depth: 773 mm (30.4 inches)

The following table lists the detailed dimensions. See the figure below for the definition of each dimension.

Table 95. Detailed dimensions

Dimension	Description
482 mm	X_a = Width, to the outsides of the front EIA flanges
435 mm	X_b = Width, to the rack rail mating surfaces
440 mm	X_c = Width, to the outer most chassis body feature
43 mm	Y_a = Height, from the bottom of chassis to the top of the chassis
724 mm	Z_a = Depth, from the rack flange mating surface to the rearmost I/O port surface
738 mm	Z_b = Depth, from the rack flange mating surface to the rearmost feature of the chassis body
754 mm ($\leq 1100W$) 782 mm (1800W)	Z_c = Depth, from the rack flange mating surface to the rearmost feature such as power supply handle
36 mm	Z_d = Depth, from the forwardmost feature on front of EIA flange to the rack flange mating surface
47 mm	Z_e = Depth, from the front of security bezel (if applicable) or forwardmost feature to the rack flange mating surface

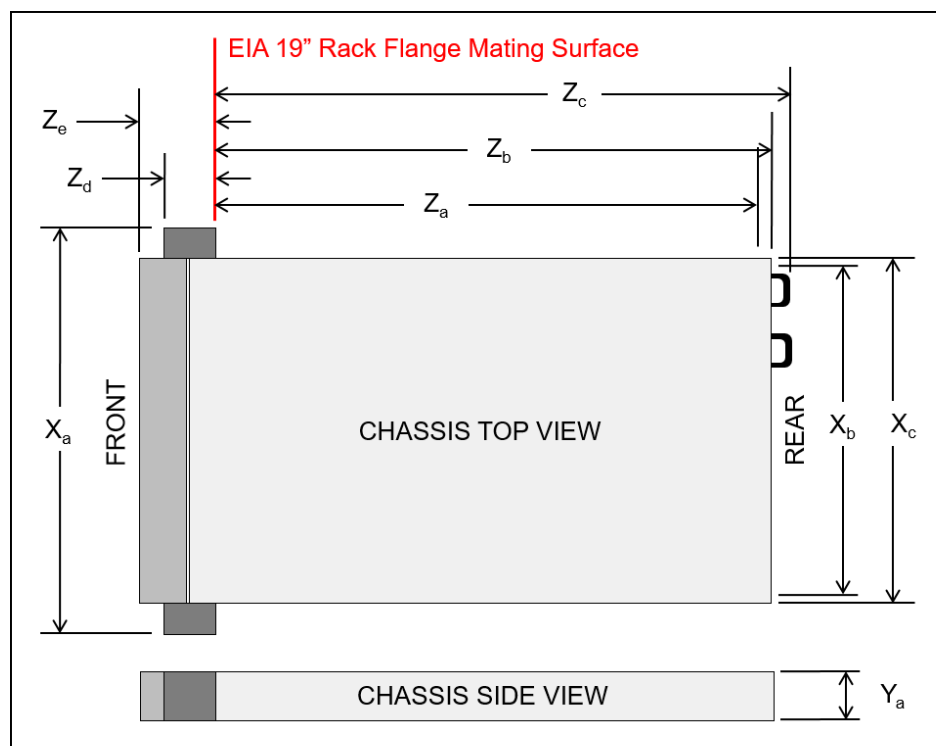

Figure 26. Server dimensions

The shipping (cardboard packaging) dimensions of the SR645 V3 are as follows:

- Width: 587 mm (23.1 inches)
- Height: 225 mm (8.9 inches)
- Depth: 998 mm (39.3 inches)

The server has the following weight:

- Maximum weight: 20.2 kg (44.6 lb)

The server has the following electrical specifications for AC input power supplies:

- Input voltage:
 - 100 to 127 (nominal) Vac, 50 Hz or 60 Hz
 - 200 to 240 (nominal) Vac, 50 Hz or 60 Hz
 - 180 to 300 Vdc (China only)
- Inlet current: see the following table.

Table 96. Maximum inlet current

Part number	Description	100V AC	200V AC	220V AC	240V DC
AC input power - 80 PLUS Titanium efficiency					
4P57A82019	ThinkSystem 750W 230V Titanium Hot-Swap Gen2 Power Supply v3	No support	4A	3.6A	3.3A
4P57A72666	ThinkSystem 1100W 230V Titanium Hot-Swap Gen2 Power Supply	No support	5.9A	5.3A	5A
4P57A78359	ThinkSystem 1800W 230V Titanium Hot-Swap Gen2 Power Supply	No support	9.7A	8.7A	8.3A
AC input power - 80 PLUS Platinum efficiency					
4P57A72670	ThinkSystem 750W 230V/115V Platinum Hot-Swap Gen2 Power Supply v3	8.4A	4.1A	3.69A	3.5A
4P57A72671	ThinkSystem 1100W 230V/115V Platinum Hot-Swap Gen2 Power Supply v3	12A	6A	5.4A	5.1A
4P57A78362	ThinkSystem 1800W 230V Platinum Hot-Swap Gen2 Power Supply v2	No support	10A	9.1A	9A

Electrical specifications for DC input power supply:

- Input voltage: -48 to -60 Vdc
- Inlet current (1100W power supply): 26 A

Operating environment

The SR645 V3 server complies with ASHRAE Class A2 specifications with most configurations, and depending on the hardware configuration, also complies with ASHRAE Class A3 and Class A4 specifications. System performance may be impacted when operating temperature is outside ASHRAE A2 specification.

Depending on the hardware configuration, the SR645 V3 server also complies with ASHRAE Class H1 specification. System performance may be impacted when operating temperature is outside ASHRAE H1 specification.

Topics in this section:

- [Ambient temperature requirements](#)
- [Temperature and humidity](#)
- [Acoustical noise emissions](#)
- [Shock and vibration](#)

Ambient temperature requirements

Additional restrictions to ASHRAE support, based on server configuration, are as follows:

- The ambient temperature must be no more than 25°C if your server meets any of the following condition:
 - $320\text{ W} \leq \text{TDP} \leq 400\text{ W}$
- The ambient temperature must be no more than 30°C if your server meets any of the following conditions:
 - $240\text{ W} < \text{TDP} \leq 300\text{ W}$
 - $\text{AOC} \geq 100\text{ GB}$
 - Installed with any rear 2.5-inch NVMe/SAS/SATA drive
 - Installed with any TruDDR5 memory DIMM (256 GB or above)
 - Installed with any passive GPU
- The ambient temperature must be no more than 35°C if your server meets any of the following conditions:
 - $200\text{ W} \leq \text{TDP} \leq 240\text{ W}$
 - Installed with any 7mm boot drive
 - Installed with any M.2 NVMe drive
 - Installed with no less than four front 2.5" hot-swap drives
- The ambient temperature must be no more than 45°C if the CPU TDP $\leq 200\text{ W}$.

For additional information, see the Environmental specifications and Thermal rules sections in the product documentation:

https://pubs.lenovo.com/sr645-v3/server_specifications_environmental

https://pubs.lenovo.com/sr645-v3/thermal_rules

Temperature and humidity

The server is supported in the following environment:

- Air temperature:
 - Operating:
 - ASHRAE Class A2: 10°C to 35°C (50°F to 95°F); the maximum ambient temperature decreases by 1°C for every 300 m (984 ft) increase in altitude above 900 m (2,953 ft).
 - ASHRAE Class A3: 5°C to 40°C (41°F to 104°F); the maximum ambient temperature decreases by 1°C for every 175 m (574 ft) increase in altitude above 900 m (2,953 ft).
 - ASHRAE Class A4: 5°C to 45°C (41°F to 113°F); the maximum ambient temperature decreases by 1°C for every 125 m (410 ft) increase in altitude above 900 m (2,953 ft).

- ASHRAE Class H1: 5 °C to 25 °C (41 °F to 77 °F); Decrease the maximum ambient temperature by 1°C for every 500 m (1640 ft) increase in altitude above 900 m (2,953 ft).
 - Server off: 5°C to 45°C (41°F to 113°F)
 - Shipment/storage: -40°C to 60°C (-40°F to 140°F)
- Maximum altitude: 3,050 m (10,000 ft)
- Relative Humidity (non-condensing):
 - Operating
 - ASHRAE Class A2: 8% to 80%; maximum dew point: 21°C (70°F)
 - ASHRAE Class A3: 8% to 85%; maximum dew point: 24°C (75°F)
 - ASHRAE Class A4: 8% to 90%; maximum dew point: 24°C (75°F)
 - ASHRAE Class H1: 8% to 80%; Maximum dew point: 17°C (63°F)
 - Shipment/storage: 8% to 90%

Acoustical noise emissions

The server has the following acoustic noise emissions declaration:

- Sound power level (L_{WA_d}):
 - Idling: 5.6 Bel(Min), 6.7 Bel (Typical), 6.7 Bel (GPU rich), 7.5 Bel (Storage rich)
 - Operating: 7.6 Bel(Min), 8.7 Bel (Typical), 8.3 Bel (GPU rich), 7.7 Bel (Storage rich)
- Sound pressure level (L_{pAm}):
 - Idling: 41.3 dBA (Min), 52.5 dBA (Typical), 52.5 dBA (GPU rich), 60.1 dBA (Storage rich)
 - Operating: 61.5 dBA (Min), 72.5 dBA (Typical), 67.8 dBA (GPU rich), 62.8 dBA (Storage rich)

Notes:

- These sound levels were measured in controlled acoustical environments according to procedures specified by ISO7779 and are reported in accordance with ISO 9296.
- The declared acoustic sound levels are based on the following configurations, which may change depending on configuration/conditions :
 - Min: 2x 240W CPU, 24x 64GB RDIMMs, 8x SAS HDD, RAID 440-16i, Broadcom 5719 1GbE RJ45 4-port OCP Ethernet Adapter, 2x 1100W PSU
 - Typical: 2x 300W CPU, 24x 64GB RDIMMs, 10x SAS HDD, RAID 940-16i, Broadcom 5719 1GbE RJ45 4-port OCP Ethernet Adapter, 2x 1100W PSU
 - GPU rich: 2x 300W CPU, 24x 64GB RDIMMs, 10x SAS HDD, RAID 940-16i, Broadcom 5719 1GbE RJ45 4-port OCP Ethernet Adapter, 1x A2 GPU, 2x 1100W PSU
 - Storage rich: 2x 240W CPU, 12x 64GB RDIMMs, 12x SAS HDD, RAID 940-16i, Broadcom 5719 1GbE RJ45 4-port OCP Ethernet Adapter, 2x 750W PSU
- Government regulations (such as those prescribed by OSHA or European Community Directives) may govern noise level exposure in the workplace and may apply to you and your server installation. The actual sound pressure levels in your installation depend upon a variety of factors, including the number of racks in the installation; the size, materials, and configuration of the room; the noise levels from other equipment; the room ambient temperature, and employee's location in relation to the equipment. Further, compliance with such government regulations depends on a variety of additional factors, including the duration of employees' exposure and whether employees wear hearing protection. Lenovo recommends that you consult with qualified experts in this field to determine whether you are in compliance with the applicable regulations.

Shock and vibration

The server has the following vibration and shock limits:

- Vibration:
 - Operating: 0.21 G rms at 5 Hz to 500 Hz for 15 minutes across 3 axes
 - Non-operating: 1.04 G rms at 2 Hz to 200 Hz for 15 minutes across 6 surfaces
- Shock:
 - Operating: 15 G for 3 milliseconds in each direction (positive and negative X, Y, and Z axes)
 - Non-operating:
 - 12 kg - 22 kg: 50 G for 152 in./sec velocity change across 6 surfaces

Water infrastructure for the Lenovo Neptune Processor DWC Module

The Lenovo Processor Neptune Core Module is the liquid-based processor cooling offering for the SR645 V3, as described in the [Lenovo Processor Neptune Core Module](#) section.

The open-loop cooling module requires the following water infrastructure components in the rack cabinet and data center:

- Supported 42U or 48U rack cabinet
The 42U or 48U Heavy Duty Rack Cabinet (machine types 7D6D or 7D6E) are supported. Two 0U mounting points are required for the water manifolds, at the rear of the rack cabinet, one either side.

For information about the 42U and 48U Heavy Duty Rack Cabinets, see the product guide: <https://lenovopress.lenovo.com/lp1498-lenovo-heavy-duty-rack-cabinets>
- 38-port water manifold (machine type 7DE6), installed in the rear of the rack cabinet
The manifold provides quick-disconnect couplings that each server in the rack are connected to. Ordering information is in the table below.
- Coolant distribution unit (CDU), either in-rack or in-row
In-rack CDUs are installed at the bottom of the rack cabinet.

In-row CDUs are separate cabinets that are typically installed at the end of a row of rack cabinets. Examples of suitable in-row CDUs include (but not limited to):
 - Vertiv XDU450 CDU
 - Vertiv XDU600 CDU
 - Vertiv XDU100 CDU
- Hose kit to connect to the CDU to the manifold
Ordering information is in the table below.

The following figure shows the major components of the solution.

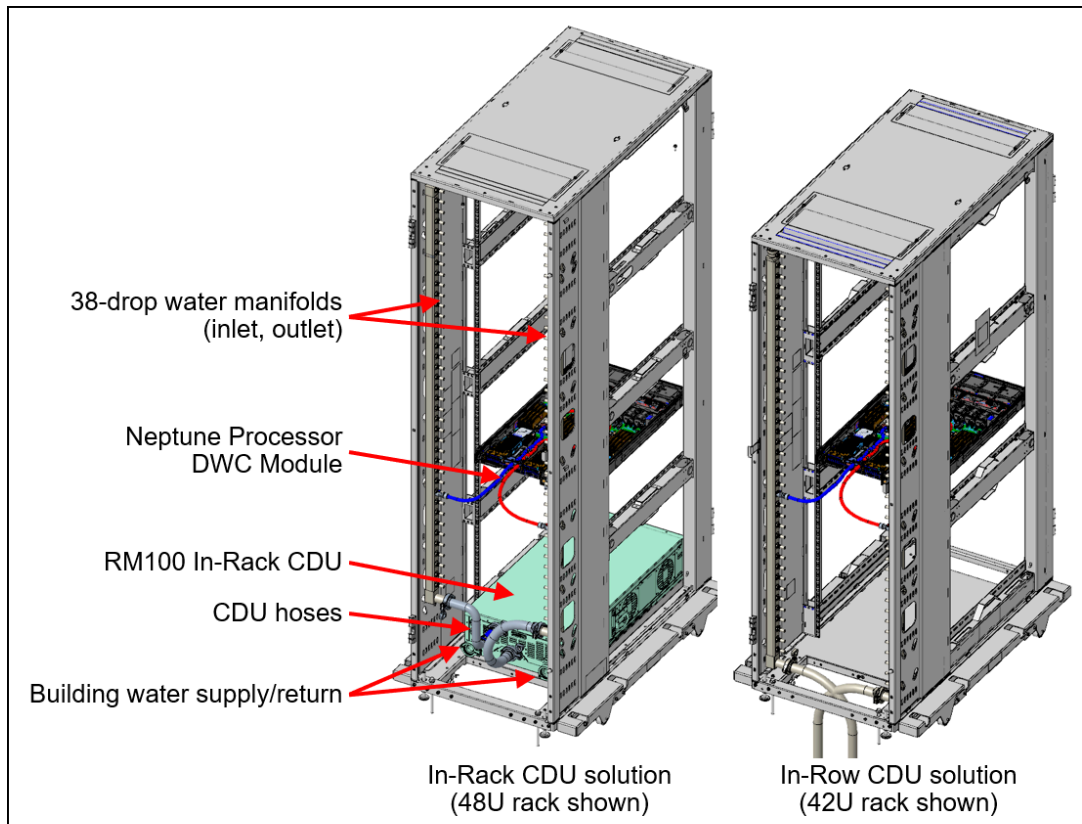

Figure 27. Water manifold connections

Configuration requirements:

- Maximum number of SR645 V3 servers supported in a rack:
 - 48U rack: 38 servers
 - 42U rack with in-rack CDU: 35 servers
 - 42U rack without in-rack CDU: 38 servers
- Inlet water flow rate:
 - 0.5 LPM: Maximum 40°C inlet water temperature
 - 1.0 LPM: Maximum 45°C inlet water temperature
 - 1.5 LPM: Maximum 50°C inlet water temperature
- Water pressure requirement:
 - Maximum operating node inlet pressure = 43.5 psi (3 bars)

Note: Water quality must be maintained over the lifetime of the system to receive warranty and support on affecting components. For water quality requirement, see [Lenovo Neptune Direct Water-Cooling Standards](#)

The 38-drop water manifold and hoses can be ordered as listed in the following table.

Table 97. Water infrastructure ordering information

Part number	Feature code	Description
Manifold for 42U and 48U rack cabinet		
4XF7A90061	C5YW	ThinkSystem Neptune 38-Port Rack Manifold
Hoses to connect the manifold to an in-rack CDU		

Part number	Feature code	Description
4XF7A90232	C5YX	Connection Set, 38/45 Ports Manifold with in-rack CDU
4XF7A90233	C5YY	Connection Set, 38-Port Manifold with in-rack CDU for 48U Rack
Hoses to connect the manifold to an in-row CDU		
4XF7A90234	C5YZ	Hose Set, 1 inch EPDM, 1.3m, for Rack Manifold with in-row CDU
4XF7A90235	C5Z0	Hose Set, 1 inch EPDM, 2.3m, for Rack Manifold with in-row CDU

Configuration notes:

- This water connection solution described here cannot be used with the DW612S and N1380 enclosures as the water requirements are different.
- The hoses for in-row CDUs that are listed in the table above have Eaton FD83 quick-disconnect couplings

Warranty upgrades and post-warranty support

The SR645 V3 has a 1-year or 3-year warranty based on the machine type of the system:

- 7D9D - 1 year warranty
- 7D9C - 3 year warranty

Our global network of regional support centers offers consistent, local-language support enabling you to vary response times and level of service* to match the criticality of your support needs:

- **Standard Next Business Day** – Best choice for non-essential systems requiring simple maintenance.
- **Premier Next Business Day** – Best choice for essential systems requiring technical expertise from senior-level Lenovo engineers.
- **Premier 24x7 4-Hour Response** – Best choice for systems where maximum uptime is critical.
- **Premier Enhanced Storage Support 24x7 4-Hour Response** – Best choice for storage systems where maximum uptime is critical.

For more information, consult the brochure [Lenovo Operational Support Services for Data Centers Services](#).

* Some service levels may not be available in all markets. Contact your sales representative for more information.

Services

Lenovo Data Center Services empower you at every stage of your IT lifecycle. From expert advisory and strategic planning to seamless deployment and ongoing support, we ensure your infrastructure is built for success. Our comprehensive services accelerate time to value, minimize downtime, and free your IT staff to focus on driving innovation and business growth.

Note: Some service options may not be available in all markets or regions. For more information, go to <https://lenovocator.com/>. For information about Lenovo service upgrade offerings that are available in your region, contact your local Lenovo sales representative or business partner.

In this section:

- [Lenovo Advisory Services](#)
- [Lenovo Plan & Design Services](#)
- [Lenovo Deployment, Migration, and Configuration Services](#)
- [Lenovo Support Services](#)
- [Lenovo Managed Services](#)
- [Lenovo Sustainability Services](#)

Lenovo Advisory Services

Lenovo Advisory Services simplify the planning process, enabling customers to build future-proofed strategies in as little as six weeks. Consultants provide guidance on projects including VM migration, storage, backup and recovery, and cost management to accelerate time to value, improve cost efficiency, and build a flexibly scalable foundation.

- **Assessment Services**

An Assessment helps solve your IT challenges through an onsite, multi-day session with a Lenovo technology expert. We perform a tools-based assessment which provides a comprehensive and thorough review of a company's environment and technology systems. In addition to the technology based functional requirements, the consultant also discusses and records the non-functional business requirements, challenges, and constraints. Assessments help organizations like yours, no matter how large or small, get a better return on your IT investment and overcome challenges in the ever-changing technology landscape.

- **Design Services**

Professional Services consultants perform infrastructure design and implementation planning to support your strategy. The high-level architectures provided by the assessment service are turned into low level designs and wiring diagrams, which are reviewed and approved prior to implementation. The implementation plan will demonstrate an outcome-based proposal to provide business capabilities through infrastructure with a risk-mitigated project plan.

Lenovo Plan & Design Services

Unlock faster time to market with our tailored, strategic design workshops to align solution approaches with your business goals and technical requirements. Leverage our deep solution expertise and end-to-end delivery partnership to meet your goals efficiently and effectively.

Lenovo Deployment, Migration, and Configuration Services

Optimize your IT operations by shifting labor-intensive functions to Lenovo's skilled technicians for seamless on-site or remote deployment, configuration, and migration. Enjoy peace of mind, faster time to value, and

comprehensive knowledge sharing with your IT staff, backed by our best-practice methodology.

- **Deployment Services for Storage and ThinkAgile**

A comprehensive range of remote and onsite options tailored specifically for your business needs to ensure your storage and ThinkAgile hardware are fully operational from the start.

- **Hardware Installation Services**

A full-range, comprehensive setup for your hardware, including unpacking, inspecting, and positioning components to ensure your equipment is operational and error-free for the most seamless and efficient installation experience, so you can quickly benefit from your investments.

- **DM/DG File Migration Services**

Take the burden of file migration from your IT's shoulders. Our experts will align your requirements and business objectives to the migration plans while coordinating with your team to plan and safely execute the data migration to your storage platforms.

- **DM/DG/DE Health Check Services**

Our experts perform proactive checks of your Firmware and system health to ensure your machines are operating at peak and optimal efficiency to maximize up-time, avoid system failures, ensure the security of IT solutions and simplify maintenance.

- **Factory Integrated Services**

A suite of value-added offerings provided during the manufacturing phase of a server or storage system that reduces time to value. These services aim at improving your hardware deployment experience and enhance the quality of a standard configuration before it arrives at your facility.

Lenovo Support Services

In addition to response time options for hardware parts, repairs, and labor, Lenovo offers a wide array of additional support services to ensure your business is positioned for success and longevity. Our goal is to reduce your capital outlays, mitigate your IT risks, and accelerate your time to productivity.

- **Premier Support for Data Centers**

Your direct line to the solution that promises the best, most comprehensive level of support to help you fully unlock the potential of your data center.

- **Premier Enhanced Storage Support (PESS)**

Gain all the benefits of Premier Support for Data Centers, adding dedicated storage specialists and resources to elevate your storage support experience to the next level.

- **Committed Service Repair (CSR)**

Our commitment to ensuring the fastest, most seamless resolution times for mission-critical systems that require immediate attention to ensure minimal downtime and risk for your business. This service is only available for machines under the Premier 4-Hour Response SLA.

- **Multivendor Support Services (MVS)**

Your single point of accountability for resolution support across vast range of leading Server, Storage, and Networking OEMs, allowing you to manage all your supported infrastructure devices seamlessly from a single source.

- **Keep Your Drive (KYD)**

Protect sensitive data and maintain compliance with corporate retention and disposal policies to ensure your data is always under your control, regardless of the number of drives that are installed in your Lenovo server.

- **Technical Account Manager (TAM)**

Your single point of contact to expedite service requests, provide status updates, and furnish reports to track incidents over time, ensuring smooth operations and optimized performance as your business grows.

- **Enterprise Software Support (ESS)**

Gain comprehensive, single-source, and global support for a wide range of server operating systems and Microsoft server applications.

For more information, consult the brochure [Lenovo Operational Support Services for Data Centers](#).

Lenovo Managed Services

Achieve peak efficiency, high security, and minimal disruption with Lenovo's always-on Managed Services. Our real-time monitoring, 24x7 incident response, and problem resolution ensure your infrastructure operates seamlessly. With quarterly health checks for ongoing optimization and innovation, Lenovo's remote active monitoring boosts end-user experience and productivity by keeping your data center's hardware performing at its best.

Lenovo Managed Services provides continuous 24x7 remote monitoring (plus 24x7 call center availability) and proactive management of your data center using state-of-the-art tools, systems, and practices by a team of highly skilled and experienced Lenovo services professionals.

Quarterly reviews check error logs, verify firmware & OS device driver levels, and software as needed. We'll also maintain records of latest patches, critical updates, and firmware levels, to ensure you systems are providing business value through optimized performance.

Lenovo Sustainability Services

- **Asset Recovery Services**

Lenovo Asset Recovery Services (ARS) provides a secure, seamless solution for managing end-of-life IT assets, ensuring data is safely sanitized while contributing to a more circular IT lifecycle. By maximizing the reuse or responsible recycling of devices, ARS helps businesses meet sustainability goals while recovering potential value from their retired equipment. For more information, see the [Asset Recovery Services offering page](#).

- **CO2 Offset Services**

Lenovo's CO2 Offset Services offer a simple and transparent way for businesses to take tangible action on their IT footprint. By integrating CO2 offsets directly into device purchases, customers can easily support verified climate projects and track their contributions, making meaningful progress toward their sustainability goals without added complexity.

- **Lenovo Certified Refurbished**

Lenovo Certified Refurbished offers a cost-effective way to support IT circularity without compromising on quality and performance. Each device undergoes rigorous testing and certification, ensuring reliable performance and extending its lifecycle. With Lenovo's trusted certification, you gain peace of mind while making a more sustainable IT choice.

Lenovo TruScale

Lenovo TruScale XaaS is your set of flexible IT services that makes everything easier. Streamline IT procurement, simplify infrastructure and device management, and pay only for what you use – so your business is free to grow and go anywhere.

Lenovo TruScale is the unified solution that gives you simplified access to:

- The industry's broadest portfolio – from pocket to cloud – all delivered as a service
- A single-contract framework for full visibility and accountability
- The global scale to rapidly and securely build teams from anywhere
- Flexible fixed and metered pay-as-you-go models with minimal upfront cost
- The growth-driving combination of hardware, software, infrastructure, and solutions – all from one single provider with one point of accountability.

For information about Lenovo TruScale offerings that are available in your region, contact your local Lenovo sales representative or business partner.

Regulatory compliance

The SR645 V3 conforms to the following standards:

- ANSI/UL 62368-1
- IEC 62368-1 (CB Certificate and CB Test Report)
- CSA C22.2 No. 62368-1
- Mexico NOM-019
- India BIS 13252 (Part 1)
- Germany GS
- TUV-GS (EN62368-1, and EK1-ITB2000)
- Brazil INMETRO
- Ukraine UkrCEPRO
- Morocco CMIM Certification (CM)
- Russia, Belorussia and Kazakhstan, TP EAC 037/2016 (for RoHS)
- Russia, Belorussia and Kazakhstan, EAC: TP TC 004/2011 (for Safety); TP TC 020/2011 (for EMC)
- CE, UKCA Mark (EN55032 Class A, EN62368-1, EN55024, EN55035, EN61000-3-2, EN61000-3-3, (EU) 2019/424, and EN IEC 63000 (RoHS))
- FCC - Verified to comply with Part 15 of the FCC Rules, Class A
- Canada ICES-003, issue 7, Class A
- CISPR 32, Class A, CISPR 35
- Korea KN32, Class A, KN35
- Japan VCCI, Class A
- Taiwan BSMI CNS15936, Class A; CNS15598-1; Section 5 of CNS15663
- Australia/New Zealand AS/NZS CISPR 32, Class A; AS/NZS 62368.1
- UL Green Guard, UL2819
- [Energy Star 4.0](#)
- EPEAT (NSF/ ANSI 426) Bronze
- Japanese Energy-Saving Act
- China CCC certificate, GB17625.1; GB4943.1; GB/T9254
- China CECP certificate, CQC3135
- China CELP certificate, HJ 2507-2011

External drive enclosures

The server supports attachment to external drive enclosures using a RAID controller with external ports or a SAS host bus adapter. Adapters supported by the server are listed in the [SAS adapters for external storage](#) section.

Note: Information provided in this section is for ordering reference purposes only. For the operating system and adapter support details, refer to the interoperability matrix for a particular storage enclosure that can be found on the Lenovo Data Center Support web site:

<http://datacentersupport.lenovo.com>

Table 98. External drive enclosures

Model	Description
4587HC1	Lenovo Storage D1212 Disk Expansion Enclosure (2U enclosure with 12x LFF drive bays)
4587HC2	Lenovo Storage D1224 Disk Expansion Enclosure (2U enclosure with 24x SFF drive bays)
7DAHCTO1WW	Lenovo ThinkSystem D4390 Direct Attached Storage (4U enclosure with 90x LFF drive bays)

For details about supported drives, adapters, and cables, see the following Lenovo Press Product Guides:

- Lenovo Storage D1212 and D1224
<http://lenovopress.lenovo.com/lp0512>
- Lenovo ThinkSystem D4390
<https://lenovopress.lenovo.com/lp1681>

External storage systems

Lenovo offers the ThinkSystem DE Series, ThinkSystem DG Series, ThinkSystem DM Series and ThinkSystem DS Series external storage systems for high-performance storage. See the DE Series, DG Series and DM Series product guides for specific controller models, expansion enclosures and configuration options:

- ThinkSystem DE Series Storage
<https://lenovopress.com/storage/thinksystem/de-series#rt=product-guide>
- ThinkSystem DS Series Storage
<https://lenovopress.lenovo.com/storage/thinksystem/ds-series>
- ThinkSystem DM Series Storage
<https://lenovopress.com/storage/thinksystem/dm-series#rt=product-guide>
- ThinkSystem DG Series Storage
<https://lenovopress.com/storage/thinksystem/dg-series#rt=product-guide>

External backup units

The following table lists the external backup options that are offered by Lenovo.

Table 99. External backup options

Part number	Description
External RDX USB drives	
4T27A10725	ThinkSystem RDX External USB 3.0 Dock
External SAS tape backup drives	
6160S8E	IBM TS2280 Tape Drive Model H8S
6160S9E	IBM TS2290 Tape Drive Model H9S
External SAS tape backup autoloaders	
6171S8R	IBM TS2900 Tape Autoloader w/LTO8 HH SAS
6171S9R	IBM TS2900 Tape Autoloader w/LTO9 HH SAS
External tape backup libraries	
6741B1F	IBM TS4300 3U Tape Library Base Unit - Max 48U
6741B3F	IBM TS4300 3U Tape Library Expansion Unit - Max 48U
SAS backup drives for TS4300 Tape Library	
01KP937	LTO 7 HH SAS Drive
01KP953	LTO 8 HH SAS Drive
02JH836	LTO 9 HH SAS Drive
Full High 8 Gb Fibre Channel for TS4300	
01KP938	LTO 7 FH Fibre Channel Drive
01KP954	LTO 8 FH Fibre Channel Drive
02JH837	LTO 9 FH Fibre Channel Drive
Half High 8 Gb Fibre Channel for TS4300	
01KP936	LTO 7 HH Fibre Channel Drive
01KP952	LTO 8 HH Fibre Channel Drive
02JH835	LTO 9 HH Fibre Channel Drive
Half High 6 Gb SAS for TS4300	
01KP937	LTO 7 HH SAS Drive
01KP953	LTO 8 HH SAS Drive
02JH836	LTO 9 HH SAS Drive

For more information, see the list of Product Guides in the Backup units category:

<https://lenovopress.com/servers/options/backup>

Fibre Channel SAN switches

Lenovo offers the ThinkSystem DB Series of Fibre Channel SAN switches for high-performance storage expansion. See the DB Series product guides for models and configuration options:

- ThinkSystem DB Series SAN Switches:
<https://lenovopress.com/storage/switches/rack#rt=product-guide>

Uninterruptible power supply units

The following table lists the uninterruptible power supply (UPS) units that are offered by Lenovo.

Table 100. Uninterruptible power supply units

Part number	Description
Rack-mounted or tower UPS units - 200-240VAC	
7DD5A002WW	RT1.5kVA 2U Rack or Tower UPS-G2 (200-240VAC)
7DD5A005WW	RT3kVA 2U Rack or Tower UPS-G2 (200-240VAC)

For more information, see the list of Product Guides in the UPS category:

<https://lenovopress.com/servers/options/ups>

Power distribution units

The following table lists the power distribution units (PDUs) that are offered by Lenovo.

Table 101. Power distribution units

Part number	Feature code	Description	ANZ	ASEAN	Brazil	EET	MEA	RUCIS	WE	HTK	INDIA	JAPAN	LA	NA	PRC
0U Basic PDUs															
4PU7A93176	C0QH	0U 36 C13 and 6 C19 Basic 32A 1 Phase PDU v2	Y	Y	Y	Y	Y	Y	Y	Y	Y	N	Y	Y	Y
4PU7A93177	C0QJ	0U 24 C13/C15 and 24 C13/C15/C19 Basic 32A 3 Phase WYE PDU v2	Y	Y	Y	Y	Y	Y	Y	Y	Y	Y	Y	Y	Y
0U Switched and Monitored PDUs															
4PU7B08148	CD15	0U 3 C13 and 18 C19 Monitored 48A 3 Phase WYE PDU	N	N	N	N	N	N	N	N	N	N	N	Y	N
4PU7B08149	CD16	0U 3 C13 and 18 C19 Monitored 63A 3 Phase WYE PDU	N	N	N	Y	N	N	Y	N	N	N	N	N	N
4PU7A93181	C0QN	0U 21 C13/C15 and 21 C13/C15/C19 Switched and Monitored 48A 3 Phase Delta PDU v2 (60A derated)	N	Y	N	N	N	N	N	Y	N	Y	N	Y	N
4PU7A93178	C0QK	0U 20 C13 and 4 C19 Switched and Monitored 32A 1 Phase PDU v2	Y	Y	Y	Y	Y	Y	Y	Y	Y	N	Y	Y	Y
4PU7A93182	C0QP	0U 18 C13/C15 and 18 C13/C15/C19 Switched and Monitored 63A 3 Phase WYE PDU v2	Y	Y	Y	Y	Y	Y	Y	Y	Y	Y	Y	Y	Y
4PU7A93175	C0CS	0U 18 C13/C15 and 18 C13/C15/C19 Switched and Monitored 63A 3 Phase WYE PDU	Y	Y	Y	Y	Y	Y	Y	Y	Y	N	Y	Y	Y
4PU7A93180	C0QM	0U 18 C13/C15 and 18 C13/C15/C19 Switched and Monitored 32A 3 Phase WYE PDU v2	Y	Y	Y	Y	Y	Y	Y	Y	Y	Y	Y	Y	Y
4PU7A93179	C0QL	0U 16 C13/C15 and 16 C13/C15/C19 Switched and Monitored 24A 1 Phase PDU v2 (30A derated)	N	Y	N	N	N	N	N	Y	N	Y	Y	Y	N
1U Basic PDUs															
4PU7B12339	CE6L	1U Basic 16A 1 Phase PDU	Y	Y	Y	Y	Y	Y	Y	Y	Y	N	Y	Y	Y
1U Switched and Monitored PDUs															
4PU7A90808	C0D4	1U 18 C19/C13 Switched and monitored 48A 3P WYE PDU V2 ETL	N	N	N	N	N	N	N	Y	N	Y	Y	Y	N
4PU7A90809	C0DE	1U 18 C19/C13 Switched and monitored 48A 3P WYE PDU V2 CE	Y	Y	Y	Y	Y	Y	Y	Y	Y	Y	Y	N	Y
4PU7A90810	C0DD	1U 18 C19/C13 Switched and monitored 80A 3P Delta PDU V2	N	N	N	N	N	N	N	Y	N	Y	Y	Y	N
4PU7A90811	C0DC	1U 12 C19/C13 Switched and monitored 32A 3P WYE PDU V2	Y	Y	Y	Y	Y	Y	Y	Y	Y	Y	Y	Y	Y
4PU7A90812	C0DB	1U 12 C19/C13 Switched and monitored 60A 3P Delta PDU V2	N	N	N	N	N	N	N	Y	N	Y	Y	Y	N
Line cords for 1U PDUs that ship without a line cord															
40K9611	6504	4.3m, 32A/380-415V, EPDU/IEC 309 3P+N+G 3ph wye (non-US) Line Cord	Y	Y	Y	Y	Y	Y	Y	Y	Y	Y	Y	Y	Y
40K9612	6502	4.3m, 32A/230V, EPDU to IEC 309 P+N+G (non-US) Line Cord	Y	Y	Y	Y	Y	Y	Y	Y	Y	Y	Y	Y	Y

Part number	Feature code	Description	ANZ	ASEAN	Brazil	EET	MEA	RUCIS	WE	HTK	INDIA	JAPAN	LA	NA	PRC
40K9613	6503	4.3m, 63A/230V, EPDU to IEC 309 P+N+G (non-US) Line Cord	Y	Y	Y	Y	Y	Y	Y	Y	Y	Y	Y	Y	Y
40K9614	6500	4.3m, 30A/208V, EPDU to NEMA L6-30P (US) Line Cord	Y	Y	Y	Y	Y	Y	Y	Y	Y	Y	Y	Y	Y
40K9615	6501	4.3m, 60A/208V, EPDU to IEC 309 2P+G (US) Line Cord	N	N	Y	N	N	N	Y	N	N	Y	Y	Y	N

For more information, see the Lenovo Press documents in the PDU category:
<https://lenovopress.com/servers/options/pdu>

Rack cabinets

The following table lists the supported rack cabinets.

Table 102. Rack cabinets

Model	Description
7D6DA007WW	ThinkSystem 42U Onyx Primary Heavy Duty Rack Cabinet (1200mm)
7D6DA008WW	ThinkSystem 42U Pearl Primary Heavy Duty Rack Cabinet (1200mm)
7D6EA009WW	ThinkSystem 48U Onyx Primary Heavy Duty Rack Cabinet (1200mm)
7D6EA00AWW	ThinkSystem 48U Pearl Primary Heavy Duty Rack Cabinet (1200mm)
1410O42	Lenovo EveryScale 42U Onyx Heavy Duty Rack Cabinet
1410P42	Lenovo EveryScale 42U Pearl Heavy Duty Rack Cabinet
1410O48	Lenovo EveryScale 48U Onyx Heavy Duty Rack Cabinet
1410P48	Lenovo EveryScale 48U Pearl Heavy Duty Rack Cabinet
93072RX	25U Standard Rack (1000mm)
93072PX	25U Static S2 Standard Rack (1000mm)
93074RX	42U Standard Rack (1000mm)
93604PX	42U 1200mm Deep Dynamic Rack
93614PX	42U 1200mm Deep Static Rack
93634PX	42U 1100mm Dynamic Rack
93634EX	42U 1100mm Dynamic Expansion Rack

For specifications about these racks, see the Lenovo Rack Cabinet Reference, available from:
<https://lenovopress.com/lp1287-lenovo-rack-cabinet-reference>

For more information, see the list of Product Guides in the Rack cabinets category:
<https://lenovopress.com/servers/options/racks>

KVM console options

The following table lists the supported KVM consoles.

Table 103. KVM console

Part number	Description
4XF7A84188	ThinkSystem 18.5" LCD console (with US English keyboard)

The following table lists the available KVM switches and the options that are supported with them.

Table 105. KVM switches and options

Part number	Description
KVM Console switches	
1754A1X	Local 1x8 Console Manager (LCM8)
Cables for GCM and LCM Console switches	
46M5383	Virtual Media Conversion Option Gen2 (VCO2)
46M5382	Serial Conversion Option (SCO)

For more information, see the list of Product Guides in the KVM Switches and Consoles category:

<http://lenovopress.com/servers/options/kvm>

Lenovo Financial Services

Why wait to obtain the technology you need now? No payments for 90 days and predictable, low monthly payments make it easy to budget for your Lenovo solution.

- **Flexible**

Our in-depth knowledge of the products, services and various market segments allows us to offer greater flexibility in structures, documentation and end of lease options.

- **100% Solution Financing**

Financing your entire solution including hardware, software, and services, ensures more predictability in your project planning with fixed, manageable payments and low monthly payments.

- **Device as a Service (DaaS)**

Leverage latest technology to advance your business. Customized solutions aligned to your needs. Flexibility to add equipment to support growth. Protect your technology with Lenovo's Premier Support service.

- **24/7 Asset management**

Manage your financed solutions with electronic access to your lease documents, payment histories, invoices and asset information.

- **Fair Market Value (FMV) and \$1 Purchase Option Leases**

Maximize your purchasing power with our lowest cost option. An FMV lease offers lower monthly payments than loans or lease-to-own financing. Think of an FMV lease as a rental. You have the flexibility at the end of the lease term to return the equipment, continue leasing it, or purchase it for the fair market value. In a \$1 Out Purchase Option lease, you own the equipment. It is a good option when you are confident you will use the equipment for an extended period beyond the finance term. Both lease types have merits depending on your needs. We can help you determine which option will best meet your technological and budgetary goals.

Ask your Lenovo Financial Services representative about this promotion and how to submit a credit application. For the majority of credit applicants, we have enough information to deliver an instant decision and send a notification within minutes.

Seller training courses

The following sales training courses are offered for employees and partners (login required). Courses are listed in date order.

1. ISG Smarter Tools, Faster Deals and Better Outcomes

2026-02-27 | 40 minutes | Employees and Partners

In this 40-minute video, we review several tools and programs from Lenovo ISG to help our Partners' Data Center selling efforts: Smarter Tools / Faster Deals / Better Outcomes. We cover Top Choice Express, our premier program for supply optimized solutions. We next demonstrated DCSC, the Data Center Solution Configurator, Compete Tool for comparisons with our competition, and XClarity One, the next evolution of our XClarity Systems Management tool.

Tags: DataCenter Products

Published: 2026-02-27

Length: 40 minutes

Start the training:

Employee link: Grow@Lenovo

Partner link: [Lenovo 360 Learning Center](#)

Course code: FEB2426

2. ThinkSystem Rackmount and Tower Servers powered by AMD

2026-02-23 | 25 minutes | Employees and Partners

This course presents the key products and features of the ThinkSystem Rackmount and Tower server family powered by AMD processors. It describes customer benefits and will help you recognize when a specific product should be selected.

By the end of this course, you should be able to:

- Identify products and features within the family
- Describe customer benefits offered by this family
- Recognize when a specific product should be selected

Last updated: 2/24/2026

Tags: Server, ThinkSystem

Published: 2026-02-23

Length: 25 minutes

Start the training:

Employee link: Grow@Lenovo

Partner link: [Lenovo 360 Learning Center](#)

Course code: SXXW1216r11

3. **OneIQ Overview and Demo**

2026-02-10 | 35 minutes | Employees and Partners

In this 35-minute video, Peter Grant, Head of Customer Experience for OneIQ, presents an overview and demo of OneIQ for Lenovo Partners.

Tags: Sales Tools

Published: 2026-02-10

Length: 35 minutes

Start the training:

Employee link: Grow@Lenovo

Partner link: [Lenovo 360 Learning Center](#)

Course code: ONEIQ101

4. **Family Portfolio: ThinkSystem Rack and Tower Servers Powered by Intel**

2026-02-04 | 25 minutes | Employees and Partners

This course is designed to give Lenovo sales and partner representatives a foundation of the ThinkSystem Intel Rackmount and Tower server family.

After completing this course, you will be able to:

- Identify products within this ThinkSystem server family
- Describe features of this family
- Recognize when a specific product should be selected

Tags: Server, ThinkSystem

Published: 2026-02-04

Length: 25 minutes

Start the training:

Employee link: Grow@Lenovo

Partner link: [Lenovo 360 Learning Center](#)

Course code: SXXW1204r15

5. **ThinkSystem Rack & Tower Server Primer - Module 2**

2025-12-17 | 45 minutes | Employees Only

This course builds on the foundational concepts from the prework modules, helping Client Managers deepen their understanding of ThinkSystem Rack and Tower Servers and apply that knowledge to confidently initiate value-driven customer conversations. Please Note: The videos in this course are taken from the Module 2 live session led by Tikiri Wandregala.

By the end of this course, you will be able to:

- Demonstrate the ability to initiate a data center discussion with a customer.
- Analyze and evaluate potential data center opportunities.
- Apply criteria to effectively qualify an opportunity.
- Locate and differentiate key resources and contacts.

Tags: DataCenter Products, ThinkSystem

Published: 2025-12-17

Length: 45 minutes

Start the training:

Employee link: Grow@Lenovo

Course code: DSRTB101

6. **Partner Technical Webinar - Mainstream CPUs**

2025-09-29 | 40 minutes | Employees and Partners

In this 40-minute replay, Brad Violand, Lenovo ISG Category team, reviewed the strategy to optimize the CPU portfolio and ensuing changes to DCSC planned for October 1, 2025.

Tags: Server

Published: 2025-09-29

Length: 40 minutes

Start the training:

Employee link: Grow@Lenovo

Partner link: [Lenovo 360 Learning Center](#)

Course code: SEP2625

7. **Partner Technical Webinar - ISG Portfolio - Wayne's World**

2025-09-25 | 60 minutes | Employees and Partners

In this 60-minute replay, Wayne Pecht, Lenovo Channel SA, shared his extensive experience and unique approach to the ISG Portfolio "Wayne's World for Lenovo ISG"!

Tags: Channel, Technical Sales

Published: 2025-09-25

Length: 60 minutes

Start the training:

Employee link: Grow@Lenovo

Partner link: [Lenovo 360 Learning Center](#)

Course code: SEP1925

8. Partner Technical Webinar - OneIQ Demo

2025-09-08 | 60 minutes | Employees and Partners

In this 60-minute replay, Joe Allen, Lenovo Senior Solution Architect for LETS, demonstrated the OneIQ tool. He showed how the collector is dispatched, how the data can be viewed, and how you build solutions based on the collected data.

Tags: Server, ThinkSystem

Published: 2025-09-08

Length: 60 minutes

Start the training:

Employee link: Grow@Lenovo

Partner link: [Lenovo 360 Learning Center](#)

Course code: SEP0525

9. Think AI Weekly: ISG & SSG Better Together: Uniting AI Solutions & Services for Smarter Outcomes

2025-08-01 | 55 minutes | Employees Only

View this session to hear from our speakers Allen Holmes, AI Technologist, ISG and Balaji Subramaniam, AI Regional Leader-Americas, SSG.

Topics include:

- An overview of ISG & SSG AI CoE Offerings with Customer Case Studies
- The Enterprise AI Deal Engagement Flow with ISG and SSG
- How sellers can leverage this partnership to differentiate with Enterprise clients.
- NEW COURSE: From Inception to Execution: Evolution of an AI Deal

Tags: Artificial Intelligence (AI), Sales, Services, Technology Solutions, TruScale Infrastructure as a Service

Published: 2025-08-01

Length: 55 minutes

Start the training:

Employee link: Grow@Lenovo

Course code: DTAIW145

10. VTT-HPC: Explaining HPC Benchmarking: Processes, Standards and Best Practices

2025-07-30 | 87 minutes | Employees Only

Please join us as Eric Michel, HPC & AI Performance Team Coordinator and Kevin Dean, Sr Manager, HPC Performance, Projection & Operations speak with us about HPC Benchmarking.

Topics will include:

- Why sellers need to request benchmarks
- How to request benchmarks
- How the team performs a benchmark
- The performance database
- Demonstration of the tool

Tags: Advanced Data Center, High Performance Computing (HPC), Technical Sales

Published: 2025-07-30

Length: 87 minutes

Start the training:

Employee link: Grow@Lenovo

Course code: DVHPC224

11. Family Portfolio: Server Component Options

2025-07-21 | 20 minutes | Employees and Partners

This course covers opportunities that are available to upsell server components. By upselling the correct components, you can increase the size and revenue of the original sale.

After completing this course, you should be able to:

- Identify the opportunities for an upsell
- Recognize when specific products should be discussed
- Emphasize how a product benefits the customer
- Identify keywords that indicate upsell opportunities

Tags: Server, Storage

Published: 2025-07-21

Length: 20 minutes

Start the training:

Employee link: Grow@Lenovo

Partner link: [Lenovo 360 Learning Center](#)

Course code: SXXW1109r2

12. ThinkSystem Rack and Tower Introduction for ISO Client Managers

2025-06-16 | 20 minutes | Employees Only

In this course, you will learn about Lenovo's Data Center Portfolio, its ThinkSystem Family and the key features of the Rack and Tower servers. It will equip you with foundational knowledge which you can then expand upon by participating in the facilitated session of the curriculum.

Tags: Server, ThinkSystem

Published: 2025-06-16

Length: 20 minutes

Start the training:

Employee link: [Grow@Lenovo](#)

Course code: DSRT0101r2_JP

13. Lenovo Data Center Product Portfolio

2025-06-11 | 20 minutes | Employees and Partners

This course introduces the Lenovo data center portfolio, and covers servers, storage, storage networking, and software-defined infrastructure products. After completing this course about Lenovo data center products, you will be able to identify product types within each data center family, describe Lenovo innovations that this product family or category uses, and recognize when a specific product should be selected.

Course objectives:

1. Identify product types within each data center family
2. Describe the features of the product family or category
3. Recognize when a specific product should be selected

Tags: Advanced DataCenter, DataCenter Products, Server, ThinkAgile, ThinkEdge, ThinkSystem

Published: 2025-06-11

Length: 20 minutes

Start the training:

Employee link: [Grow@Lenovo](#)

Partner link: [Lenovo 360 Learning Center](#)

Course code: SXXW1110r8

14. **VTT HPC: AI and the Impact on the Environment**

2025-06-11 | 58 minutes | Employees Only

Please join us as Matthew Ziegler, Director of Lenovo Neptune and Sustainability speaks with us about AI and the Impact on the Environment.

Topics will include:

- Why is ESG essential for your customer?
- How to find and read an eco declaration
- What is a product carbon footprint?
- Demo of the Lenovo Capacity Planner

Tags: Advanced DataCenter, Artificial Intelligence (AI), Environmental Social Governance (ESG), High-Performance Computing (HPC), Server

Published: 2025-06-11

Length: 58 minutes

Start the training:

Employee link: [Grow@Lenovo](#)

Course code: DVHPC223

15. **Partner Technical Webinar - RTX Pro 6000**

2025-05-22 | 60 minutes | Employees and Partners

In this 60-minute replay, Allen Bourgoyne, Product Marketing for NVIDIA, presented the newly announced RTX Pro 6000 Blackwell Server Edition GPU.

Tags: Artificial Intelligence (AI)

Published: 2025-05-22

Length: 60 minutes

Start the training:

Employee link: [Grow@Lenovo](#)

Partner link: [Lenovo 360 Learning Center](#)

Course code: MAY1525

16. **Partner Technical Webinar - DCSC Improvements - MAY0225**

2025-05-05 | 60 minutes | Employees and Partners

In this 60-minute replay, new improvements to DCSC were reviewed. Joe Allen, Lenovo NA LETS, presented the new PCI wizard and discussed RAID adapters. Ryan Tuttle, Lenovo NA LETS presented Spreadsheet import, Autocorrect and Expanded selections on by default. Joe Murphy, Lenovo NA LETS closed out with review of Error Message improvements and location of ThinkAgile MX and VX in the DCSC menus.

Tags: Technical Sales

Published: 2025-05-05

Length: 60 minutes

Start the training:

Employee link: Grow@Lenovo

Partner link: [Lenovo 360 Learning Center](#)

Course code: MAY0225

17. **Family Portfolio: Storage Controller Options**

2025-03-03 | 25 minutes | Employees and Partners

This course covers the storage controller options available for use in Lenovo servers. The classes of storage controller are discussed, along with a discussion of where they are used, and which to choose.

After completing this course, you will be able to:

- Describe the classes of storage controllers
- Discuss where each controller class is used
- Describe the available options in each controller class

Tags: Sales, Storage

Published: 2025-03-03

Length: 25 minutes

Start the training:

Employee link: Grow@Lenovo

Partner link: [Lenovo 360 Learning Center](#)

Course code: SXXW1111r2

18. **ThinkSystem Rack and Tower Introduction for ISO Client Managers**

2024-12-10 | 20 minutes | Employees Only

In this course, you will learn about Lenovo's Data Center Portfolio, its ThinkSystem Family and the key features of the Rack and Tower servers. It will equip you with foundational knowledge which you can then expand upon by participating in the facilitated session of the curriculum.

Course Objectives:

- By the end of this course, you should be able to:
- Identify Lenovo's main data center brands.
- Describe the key components of the ThinkSystem Family servers.
- Differentiate between the Rack and Tower servers of the ThinkSystem Family.
- Understand the value Rack and Tower servers can provide to customers.

Tags: Server, ThinkSystem

Published: 2024-12-10

Length: 20 minutes

Start the training:

Employee link: Grow@Lenovo

Course code: DSRT0101r2

19. **Virtual Facilitated Session - ThinkSystem Rack and Tower Primer for ISO Client Managers - HISTORICAL**

2024-10-31 | 90 minutes | Employees Only

In this Virtual Instructor-Led Training Session, ISO Client Managers will be able to build on the knowledge gained in Module 1 (eLearning) of the ThinkSystem Rack and Tower Server Primer for ISO Client Managers curriculum.

IMPORTANT! Module 1 (eLearning) must be completed to be eligible to participate in this session. Please note that places are subject to availability. If you are selected, you will receive the invite to this session via email.

Tags: Sales, Server, ThinkSystem

Published: 2024-10-31

Length: 90 minutes

Start the training:

Employee link: Grow@Lenovo

Course code: DSRT0102

20. **Q3 Solutions Launch AMD EPYC Gen5 Quick Hit**

2024-10-09 | 6 minutes | Employees and Partners

Lenovo announces upgrades to a wide range of ThinkSystem V3 servers powered by AMD processors. Support for the AMD EPYC 9005 Series processors and faster DDR5 memory will enhance the performance and power efficiency of these servers as well as the ThinkAgile systems based on them

Tags: Artificial Intelligence (AI), Server, ThinkAgile, ThinkSystem

Published: 2024-10-09

Length: 6 minutes

Start the training:

Employee link: Grow@Lenovo

Partner link: [Lenovo 360 Learning Center](#)

Course code: SXXW1216r9a

21. **SAP Webinar for Lenovo Sellers: Lenovo Portfolio Update for SAP Landscapes**

2024-06-04 | 60 minutes | Employees Only

Join Mark Kelly, Advisory IT Architect with the Lenovo Global SAP Center of Competence as he discusses:

- Challenges in the SAP environment
- Lenovo On-premise Solutions for SAP
- Lenovo support resources for SAP solutions

Tags: SAP, ThinkAgile, ThinkEdge, ThinkSystem

Published: 2024-06-04

Length: 60 minutes

Start the training:

Employee link: Grow@Lenovo

Course code: DSAPF101

22. **Introduction to DDR5 Memory**

2022-08-23 | 10 minutes | Employees and Partners

This course introduces DDR5 memory, describes new features of this memory generation, and discusses the advantages to customers of this new memory generation.

Tags: Server, Technology solutions

Published: 2022-08-23

Length: 10 minutes

Start the training:

Employee link: Grow@Lenovo

Partner link: [Lenovo 360 Learning Center](#)

Course code: SXXW2502

Related publications and links

For more information, see these resources:

- Lenovo ThinkSystem SR645 V3 product page:
<https://www.lenovo.com/us/en/p/servers-storage/servers/racks/thinksystem-sr645-v3/len21ts0008>
- ThinkSystem SR645 V3 datasheet
<https://lenovopress.com/ds0147>
- Interactive 3D Tour of the ThinkSystem SR645 V3:
<https://lenovopress.lenovo.com/lp1627-sr645-v3-3d-tour>
- ThinkSystem SR645 V3 drivers and support
<http://datacentersupport.lenovo.com/products/servers/thinksystem/sr645v3/7d9c/downloads>
- Lenovo Hardware Installation & Removal Videos on the SR645 V3:
<https://www.youtube.com/playlist?list=PLYV5R7hVcs-AXJj66KkUL7leAbhslZPkv>
- Lenovo ThinkSystem SR645 V3 product publications:
<https://pubs.lenovo.com/sr645-v3/>
 - User Guide, which includes:
 - System Configuration Guide
 - Hardware Maintenance Guide
 - Rack Installation Guides
 - Messages and Codes Reference
 - UEFI Manual for ThinkSystem Servers
- User Guides for options:
<https://serveroption.lenovo.com>
- ServerProven hardware compatibility:
<http://serverproven.lenovo.com>

Related product families

Product families related to this document are the following:

- [2-Socket Rack Servers](#)
- [ThinkSystem SR645 V3 Server](#)

Notices

Lenovo may not offer the products, services, or features discussed in this document in all countries. Consult your local Lenovo representative for information on the products and services currently available in your area. Any reference to a Lenovo product, program, or service is not intended to state or imply that only that Lenovo product, program, or service may be used. Any functionally equivalent product, program, or service that does not infringe any Lenovo intellectual property right may be used instead. However, it is the user's responsibility to evaluate and verify the operation of any other product, program, or service. Lenovo may have patents or pending patent applications covering subject matter described in this document. The furnishing of this document does not give you any license to these patents. You can send license inquiries, in writing, to:

Lenovo (United States), Inc.
8001 Development Drive
Morrisville, NC 27560
U.S.A.
Attention: Lenovo Director of Licensing

LENOVO PROVIDES THIS PUBLICATION "AS IS" WITHOUT WARRANTY OF ANY KIND, EITHER EXPRESS OR IMPLIED, INCLUDING, BUT NOT LIMITED TO, THE IMPLIED WARRANTIES OF NON-INFRINGEMENT, MERCHANTABILITY OR FITNESS FOR A PARTICULAR PURPOSE. Some jurisdictions do not allow disclaimer of express or implied warranties in certain transactions, therefore, this statement may not apply to you.

This information could include technical inaccuracies or typographical errors. Changes are periodically made to the information herein; these changes will be incorporated in new editions of the publication. Lenovo may make improvements and/or changes in the product(s) and/or the program(s) described in this publication at any time without notice.

The products described in this document are not intended for use in implantation or other life support applications where malfunction may result in injury or death to persons. The information contained in this document does not affect or change Lenovo product specifications or warranties. Nothing in this document shall operate as an express or implied license or indemnity under the intellectual property rights of Lenovo or third parties. All information contained in this document was obtained in specific environments and is presented as an illustration. The result obtained in other operating environments may vary. Lenovo may use or distribute any of the information you supply in any way it believes appropriate without incurring any obligation to you.

Any references in this publication to non-Lenovo Web sites are provided for convenience only and do not in any manner serve as an endorsement of those Web sites. The materials at those Web sites are not part of the materials for this Lenovo product, and use of those Web sites is at your own risk. Any performance data contained herein was determined in a controlled environment. Therefore, the result obtained in other operating environments may vary significantly. Some measurements may have been made on development-level systems and there is no guarantee that these measurements will be the same on generally available systems. Furthermore, some measurements may have been estimated through extrapolation. Actual results may vary. Users of this document should verify the applicable data for their specific environment.

© Copyright Lenovo 2026. All rights reserved.

This document, LP1607, was created or updated on February 20, 2026.

Send us your comments in one of the following ways:

- Use the online Contact us review form found at:
<https://lenovopress.lenovo.com/LP1607>
- Send your comments in an e-mail to:
comments@lenovopress.com

This document is available online at <https://lenovopress.lenovo.com/LP1607>.

Trademarks

Lenovo and the Lenovo logo are trademarks or registered trademarks of Lenovo in the United States, other countries, or both. A current list of Lenovo trademarks is available on the Web at <https://www.lenovo.com/us/en/legal/copytrade/>.

The following terms are trademarks of Lenovo in the United States, other countries, or both:

Lenovo®
AnyBay®
Neptune®
ServerProven®
System x®
ThinkAgile®
ThinkEdge®
ThinkShield®
ThinkSystem®
XClarity®

The following terms are trademarks of other companies:

AMD, AMD 3D V-Cache™, AMD EPYC™, and Solarflare™ are trademarks of Advanced Micro Devices, Inc.

Intel®, the Intel logo, Intel Core®, and Xeon® are trademarks of Intel Corporation or its subsidiaries.

Linux® is the trademark of Linus Torvalds in the U.S. and other countries.

Microsoft®, ActiveX®, Georgia®, PowerShell, SharePoint®, Windows PowerShell®, Windows Server®, and Windows® are trademarks of Microsoft Corporation in the United States, other countries, or both.

SPECpower® is a trademark of the Standard Performance Evaluation Corporation (SPEC).

IBM® and IBM Security® are trademarks of IBM in the United States, other countries, or both.

Other company, product, or service names may be trademarks or service marks of others.